

---

零件手册

**Parts Manual**

# 1、机壳部件 Casting mechanism

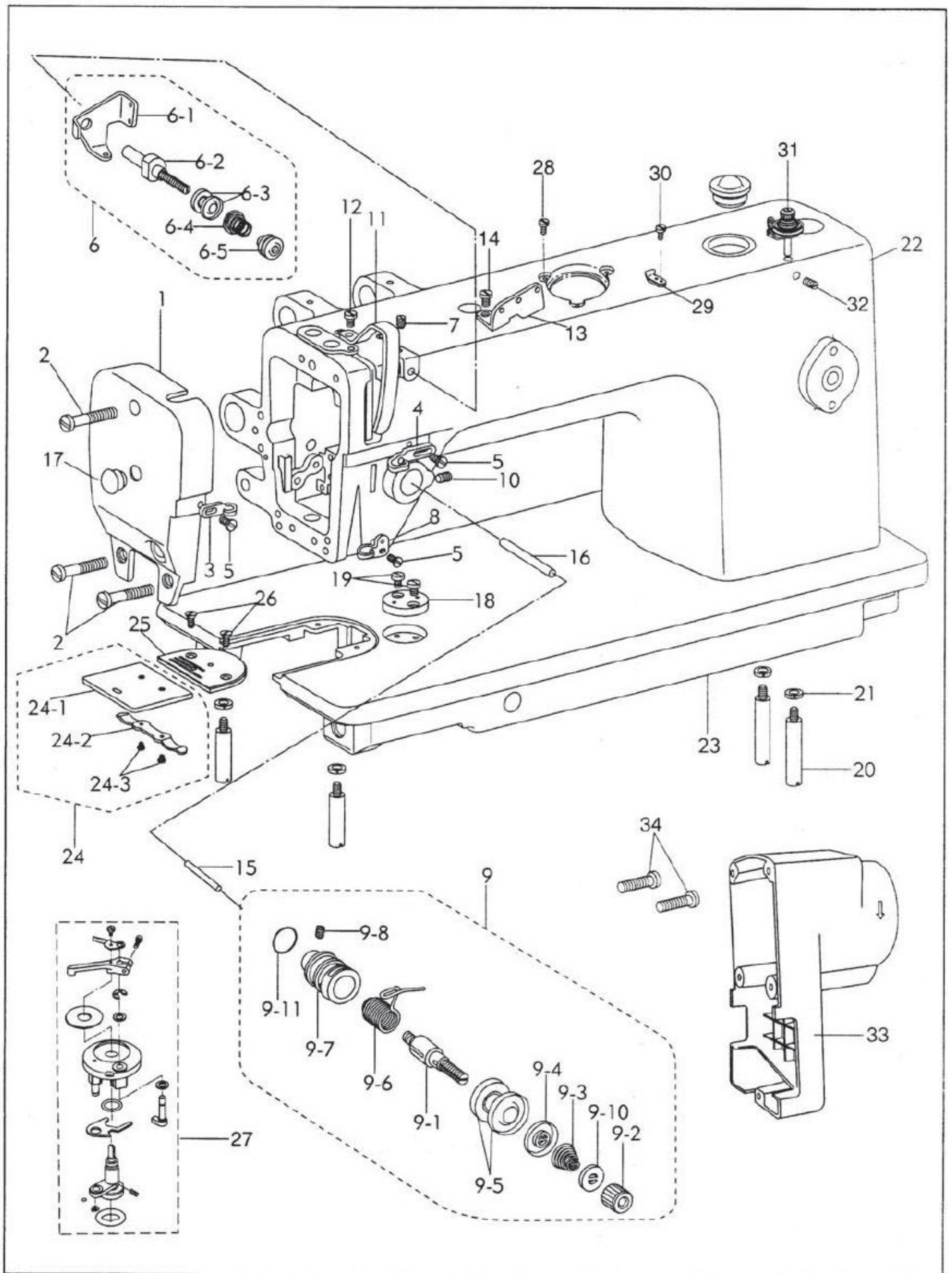

# 1、机壳部件 Casting mechanism

序号 No.	图号 Part Number	零件名称 Name	数量 Qt.	
			0303D2	6202D2
1	1KT1-002	面板	1	-
		面板	-	1
2	7WF4-004	面板螺钉	3	-
		面板螺钉	-	3
3	22T1-003C5	面板线勾	1	1
4	22T1-014	线勾	1	1
5	22T1-003C6	线勾螺钉	3	3
6	36T2-006D	小夹线组件	1	1
6-1	36T2-006D1	小夹线过线板	1	1
6-2	36T2-006D2	小夹线螺钉	1	1
6-3	22T2-009E3	小夹线组板	2	2
6-4	2KT2-011	小夹线弹簧	1	1
6-5	36T2-006D4	小夹线螺母	1	1
7	20T1-004	小夹线固定螺钉	1	1
8	7WF4-015	下线勾	1	1
9	33T4-008C	夹线组件	1	1
9-1	22T1-012F1	夹线螺钉	1	1
9-2	22T1-012F2	夹线螺母	1	1
9-3	33T4-008C1	夹线弹簧	1	1
9-4	22T1-012F4	松线板	1	1
9-5	22T1-012F5	夹线板	2	2
9-6	22T1-012F6	挑线簧	1	1
9-7	22T1-012F7	夹线调节座	1	1
9-8	22T1-012F8	夹线调节座螺钉	1	1
9-10	22T1-012F10	夹线螺母止动板	1	1
9-11	22T1-012F11	O型圈	1	1
10	22T1-013	夹线调节座固定螺钉	1	1
11	1KT1-003	挑线杆防护罩	1	1
12	22T2-004	挑线杆防护罩螺钉	1	1
13	36T2-004	三孔线勾	1	1
14	36T2-005	三孔线勾螺钉	1	1
15	2KT4-002	松线钉	1	1
16	2KT4-003	松线棒	1	1
17	7WF4-030	橡皮塞	1	1
18	7WF4-005	夹具座	1	1
19	1WF3-025	夹具座螺钉	2	2
20	7WF4-013	底板撑杆	4	4
21		底板撑杆弹簧垫片	4	4
22	271WF1-001	机壳	1	-
	258WF1-001	机壳	-	1
23	241WF1-001	底板	1	1
24		推板组件	1	1
24-1	7WF4-006	推板	1	1
24-2	20T1-013F2	推板簧	1	1
24-3	20T1-013F3	推板簧螺钉	2	2
25	2KT2-003	针板	1	1
26	22T1-020	针板螺钉	2	2
27	199WF5-012	绕线器组件	1	1
28	92WF2-027	绕线器组件固定螺钉	3	3
29	52WF2-043	切刀	1	1
30	36WF2-031	切刀螺钉	2	2
31	258WF1-005	绕线器小夹线器组件	1	-
32	1WF5-019	小夹线器固定螺钉	1	1
33	258WF1-006	电机罩	1	1
34		电机罩螺钉	5	5

## 2. 针杆、挑线部件 Needle bar and thread take-up mechanism

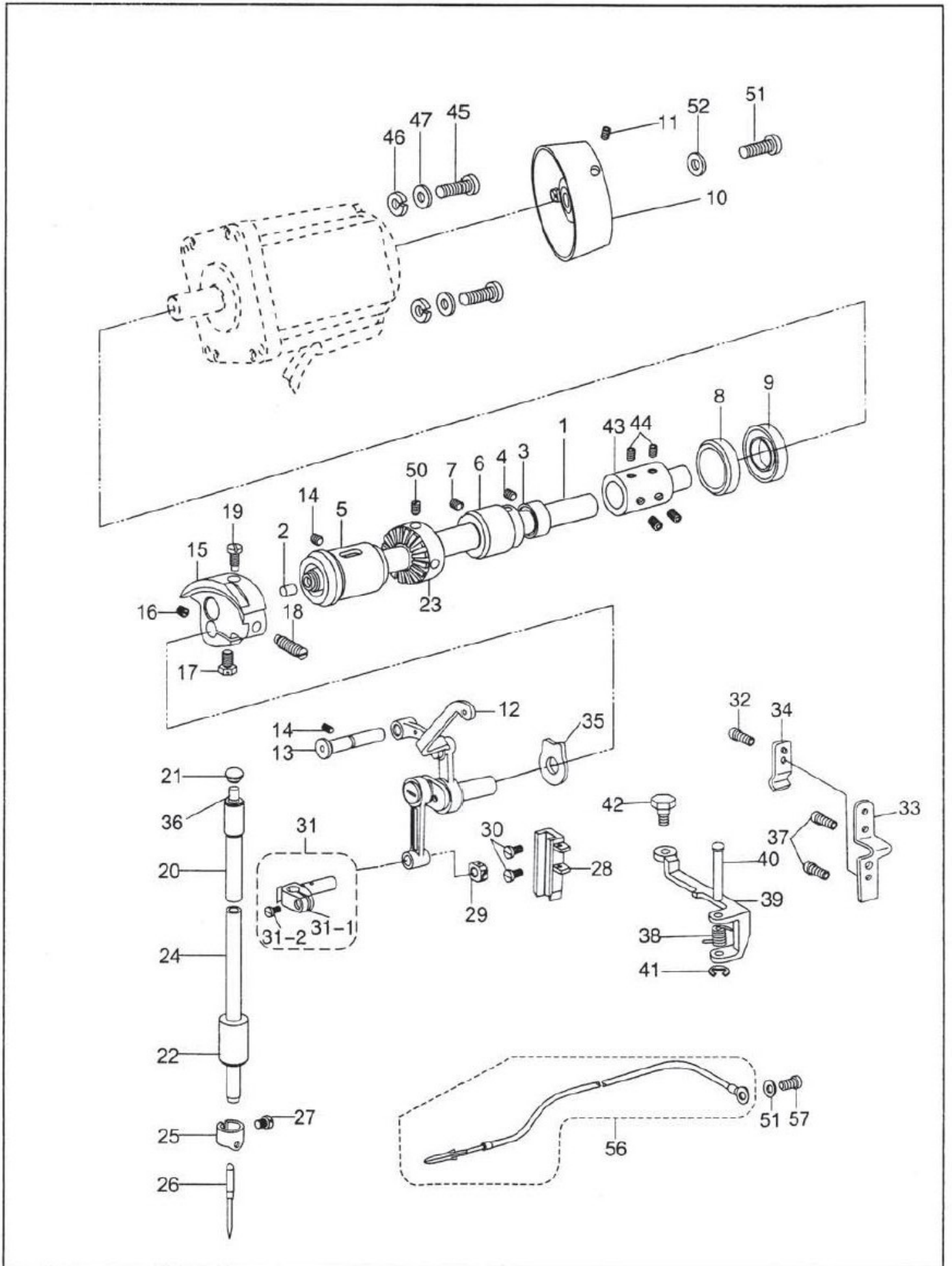

## 2. 针杆、挑线部件 Needle bar and thread take-up mechanism

序号 No.	图号 Part Number	零件名称 Name		数量 Qt.	
				0303D2	6202D2
1	271WF2-001	上轴	Upper shaft	1	1
2	22T3-001A2	上轴橡皮塞	Robber cap	1	1
3	22T3-002B1	上轴紧圈	Collar	1	1
4	22T3-002B2	上轴紧圈螺钉	Screw	2	2
5	4WF1-006A	上轴前轴套	Bush, L	1	1
6	4WF1-002	上轴中轴套	Bush, M	1	1
7	J0.0.40	上轴中轴套螺钉	Set screw	1	1
8		上轴后轴承	Bush, R	1	1
9	258WF2-004	上轴后油封组件	Oil seal	1	1
10	258WF2-006	主动轮	Hand wheel	1	1
11	258WF2-007	主动轮螺钉	Screw	2	2
12	33T1-004B	挑线杆组件	Thread take-up lever set	1	1
13	33T1-002	挑线连杆铰链轴	Support shaft	1	1
14	J0.0.5	挑线连杆铰链轴螺钉	Set screw	2	2
15	4WF1-007A	针杆曲柄	Thread take-up crank	1	1
16	33T1-006C3	挑线曲柄螺钉	Screw	1	1
17	22T2-005B3	挑线曲柄定位螺钉	Screw	1	1
18	33T1-006C2	针杆曲柄螺钉	Screw	1	1
19	20T2-007	针杆曲柄定位螺钉	Screw	1	1
20	22T2-008	针杆上轴套	Bush, U	1	1
21	22T2-011	针杆上轴套橡皮塞(φ8.8)	Rubber cap	1	1
22	2KT1-002	针杆下轴套	Bush, D	1	1
23	258WF2-002	绕线器摩擦轮	Screw	1	1
24	2KT1-001	针杆	Needle bar	1	1
25	22T2-015	针杆过线环	Thread guide	1	1
26		机针	Needle	1	1
27	22T2-017	夹针螺钉	Set screw	1	1
28	2KT1-003	滑块槽	Guide	1	1
29	33T1-013	针杆接头滑块	Slide block	1	1
30	22T2-019	滑块导轨螺钉	Screw	2	2
31	33T1-015H	针杆接头组件	Needle bar clamp assy.	1	1
31-1	22T8-001A8	针杆接头	Needle bar clamp	1	1
31-2	22T8-001A9	针杆接头螺钉	Set screw	1	1
32	2KT4-013	软线固定板螺钉	Screw	1	1
33	2KT4-010	松线钢绳固定架	Wire holder, U	1	1
34	2KT4-012	松线压板	Wire holder, D	1	1
35	33T1-005	垫片	Washer	1	1
36	22T1-010	针杆上轴套毛毡	Felt	1	1
37	2KT4-011	松线钢绳固定架螺钉	Screw	2	2
38	2KT4-006	铰链弹簧	Spring	1	1
39	2KT4-004	松线铰链	Tension release plate	1	1
40	2KT4-005	铰链销	Tension release pin	1	1
41		开口挡圈	Retaining ring	1	1
42	2KT4-009	铰链螺钉	Screw	1	1
43	258WF2-003	联轴器	Connect block	1	1
44	19WF3-005	联轴器螺钉	Screw	4	4
45		电机安装螺钉	Screw	4	4
46		弹簧垫片	Washer	4	4
47		平垫片	Washer	4	4
48	2KT8-001	地线组件	Ground wire assy.	1	1
49	2KT5-005	地线螺钉	Screw	1	1
50	6K2-043	磨擦轮螺钉	Screw	2	2
51	18WF4-023	磁钢螺钉	Screw	1	1
52	22T1-007	垫片	Washer	1	1

### 3. 压脚部件 Presser foot mechanism

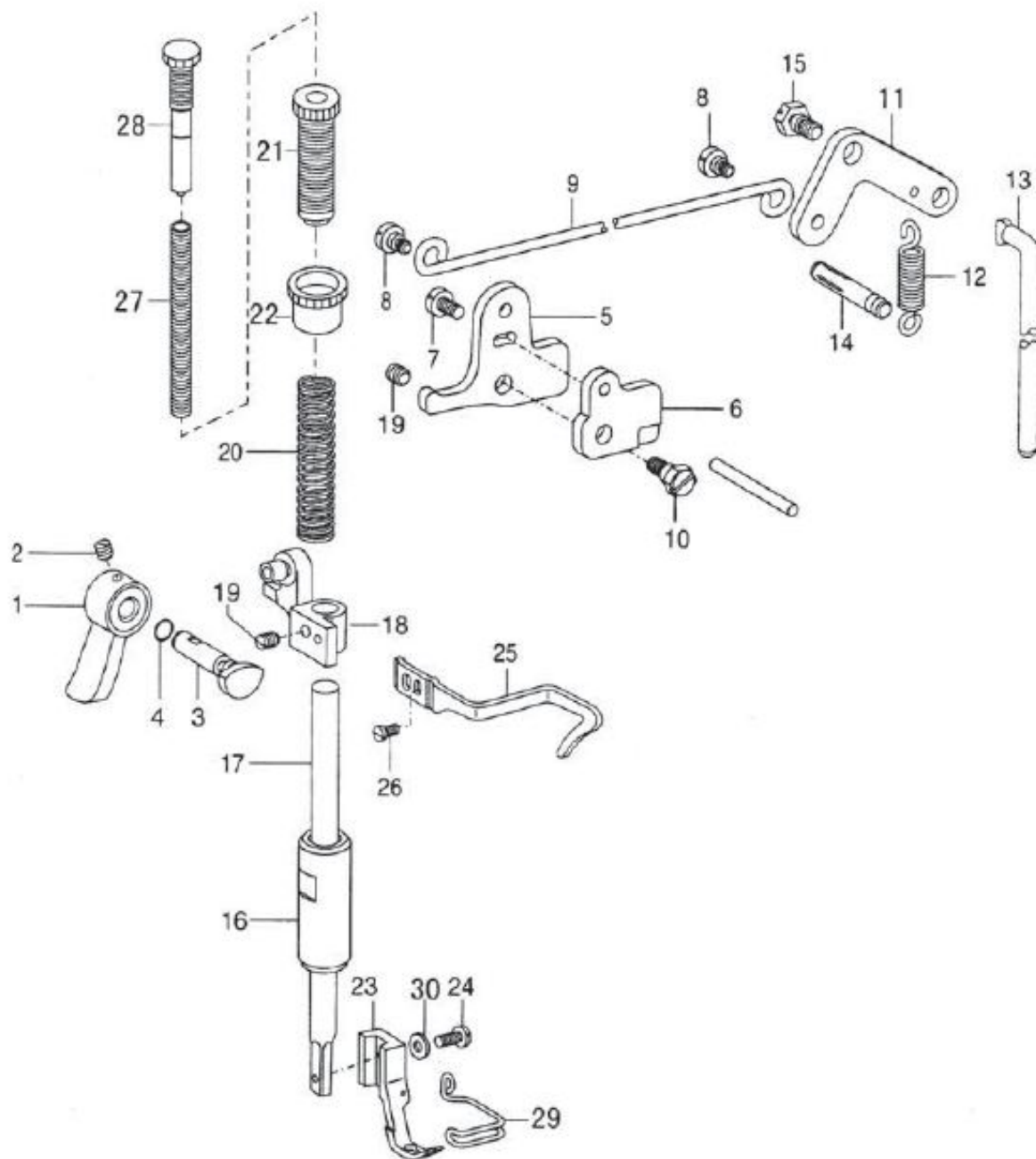

### 3. 压脚部件 Presser foot mechanism

序号 No.	图 号 Part Number	零 件 名 称 Name	数 量 Qt.		
			0303D2	6202D2	
1	33T3-003	压脚扳手	Presser bar lifter	1	1
2	22T1-011	压脚扳手螺钉	Screw	1	1
3	4WF3-002	压紧杆提升凸轮	Lifter crank	1	1
4		压紧杆提升凸轮油封	O ring	1	1
5	22T7-004B <sub>1a</sub>	膝控提升杠杆 (左)	Lifter lever	1	1
6	2KT4-001	松线凸轮	Guide plate	1	1
7	22T7-004B <sub>1c</sub>	膝控提升杠杆 (左)螺钉	Screw	1	1
8	22T7-004B <sub>2</sub>	铰链螺钉	Screw	2	2
9	1KT4-004	膝控提升拉杆	Collecting rod	1	1
10	22T7-005A	松线凸轮螺钉	Screw	1	1
11	22T7-007 <sub>c1</sub>	膝控提升杠杆 (右)	Lever	1	1
12	22T7-007 <sub>c2</sub>	膝控提升杠杆 (右)弹簧	Spring, extension	1	1
13	4WF3-001	膝控提升连杆	Knee lifter bar	1	1
14	22T7-008	弹簧销	Spring hook	1	1
15	22T7-005 <sub>B</sub>	膝控提升杆杆 (右)螺钉	Shoulder screw	1	1
16	34T3-305	压紧杆轴套	Bush	1	1
17	241WF5-001	压紧杆	Presser bar	1	1
18	7WF3-001	压紧杆导架	Guide bracket	1	1
		压紧杆导架	Guide bracket	-	1
19	61-04-01/B308	压紧杆导架螺钉	Screw	1	1
20	20T4-002	压紧杆弹簧	Spring, compression	1	1
21	233WF6-002	调压螺钉	Adjusting screw, presser	1	1
22	233WF6-003	调压螺钉锁紧螺母	Adjusting nut, presser	1	1
23	7WF3-003	小压脚	Presser foot, inside	1	1
		压脚	Presser foot, inside	1	1
24	22T7-015	小压脚螺钉	Screw	1	1
25	7WF3-002	大线勾	Thread guide	1	1
26	33T3-006	大线勾螺钉	Screw	1	1
27	233WF6-005	辅助调压弹簧	Adjusting spring	1	1
28	233WF6-004	辅助调压螺钉	Adjusting screw	1	1
29		防护勾	Safety finger	-	1
30	7WF3-004	小压脚螺钉垫片	Finger guard	1	1

## 4. 送料部件 Feed mechanism

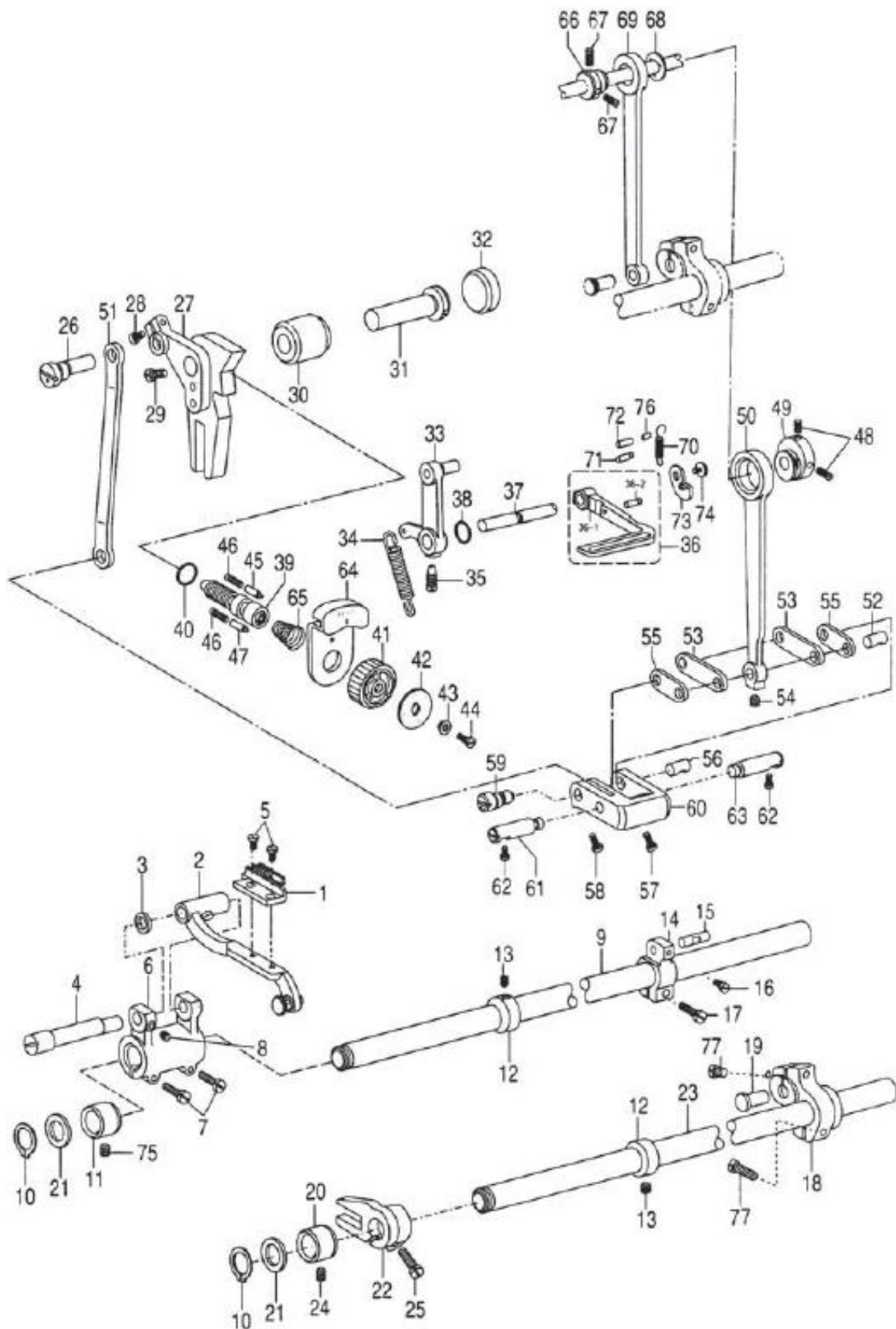



#### 4. 送料部件 Feed mechanism

序号 No.	图号 Part Number	零件名称 Name		数量 Qt.	
				0303D2	6202D2
1	2KT3-001	送布牙	Feed dog	1	1
2	36T4-001A1a1	牙架小组件	Feed bar	1	1
3	51T5-001A6	牙架垫圈	Washer	1	1
4	36T4-001A2	牙架曲柄偏心轴	Shaft	1	1
5	J0.0.50	送布牙螺钉	Screw	2	2
6	4WF2-002	牙架曲柄	Feed rock arm	1	1
7	61-04-01/B504	牙架曲柄螺钉	Screw	2	2
8	22T2-019	牙架曲柄偏心轴螺钉	Screw	1	1
9	81WF3-003	送布轴	Feed shaft	1	1
10		轴用弹性挡圈	Retaining ring	2	2
11		送布轴前轴套	Bush, L	1	1
12	22T6-004	抬牙、送布轴紧圈	Collar	2	2
13	22T3-002B1	紧圈螺钉	Set screw	4	4
14	22T3-002B2	送布轴曲柄(右)	Feed rocker arm	1	1
15	4WF2-006	曲柄连杆短销	Stud	1	1
16	82T2-003C1a10-2	曲柄连杆短销螺钉	Set screw	1	1
17	36T5-008E5	送布轴曲柄(右)螺钉	Screw	1	1
18	22T6-008D3	抬牙后曲柄	Feed lifting arm	1	1
19	68WF3-011	抬牙轴曲柄铰链轴	Pin	1	1
20	22T6-007	抬牙轴前轴套	Bush, L	1	1
21	22T6-012	抬牙、送布轴前轴套垫圈	Washer	2	2
22	51T5-013	抬牙叉	Feed lifting arm	1	1
23	36T4-018H1D1	抬牙轴	Shaft	1	1
24	7WF2-001	抬牙轴前轴套螺钉	Screw	1	1
25	J0.0.5	抬牙叉夹紧螺钉	Screw	1	1
26	22T6-008D3	针距调节连杆销	Connecting stud	1	1
27	4WF2-012	针距座	Feed regulator	1	1
28	7WF2-012	针距座长螺钉	Screw, L	1	1
29	20T2-031	针距座短螺钉	Screw, S	1	1
30	22T5-010D4	针距座衬套	Bush	1	1
31	258WF4-002	针距座轴	Shaft	1	1
32	22T5-004	橡皮塞(Φ 15.7)	Rubber cap	1	1
33	258WF4-003	倒缝操纵杆曲柄组件	Pin assy. Lever	1	1
34	7WF2-009	倒缝操纵杆曲柄弹簧	Spring, extension	1	1
35	1KT3-002	操纵杆曲柄螺钉	Screw	1	1
36	22T5-013	倒缝扳手组件	Reverse stitching lever assy.	1	1
36-1	2KT3-003	倒缝扳手	Reverse stitching lever	1	1
36-2	2KT3-003a	倒缝扳手销	Spring hook pin	1	1
37	2KT3-003b	倒缝扳手轴	Shaft	1	1
38	2KT3-002	倒缝扳手轴O型圈	O ring	1	1
39		针距调节螺杆	Adjusting screw	1	1
40	36T5-007D1	O型橡胶圈	O ring	1	1
41	33T2-030-A	针距盘	Stitch length dial	1	1
42	36T5-007D2	针距标盘	Stitch length plate	1	1
43	4WF2-004A	标盘螺钉衬套	Support bush	1	1
44	36T5-007D4	针距盘螺钉	Screw	1	1
45	36T5-007D5	止动销	Positioning pin	1	1

#### 4. 送料部件 Feed mechanism

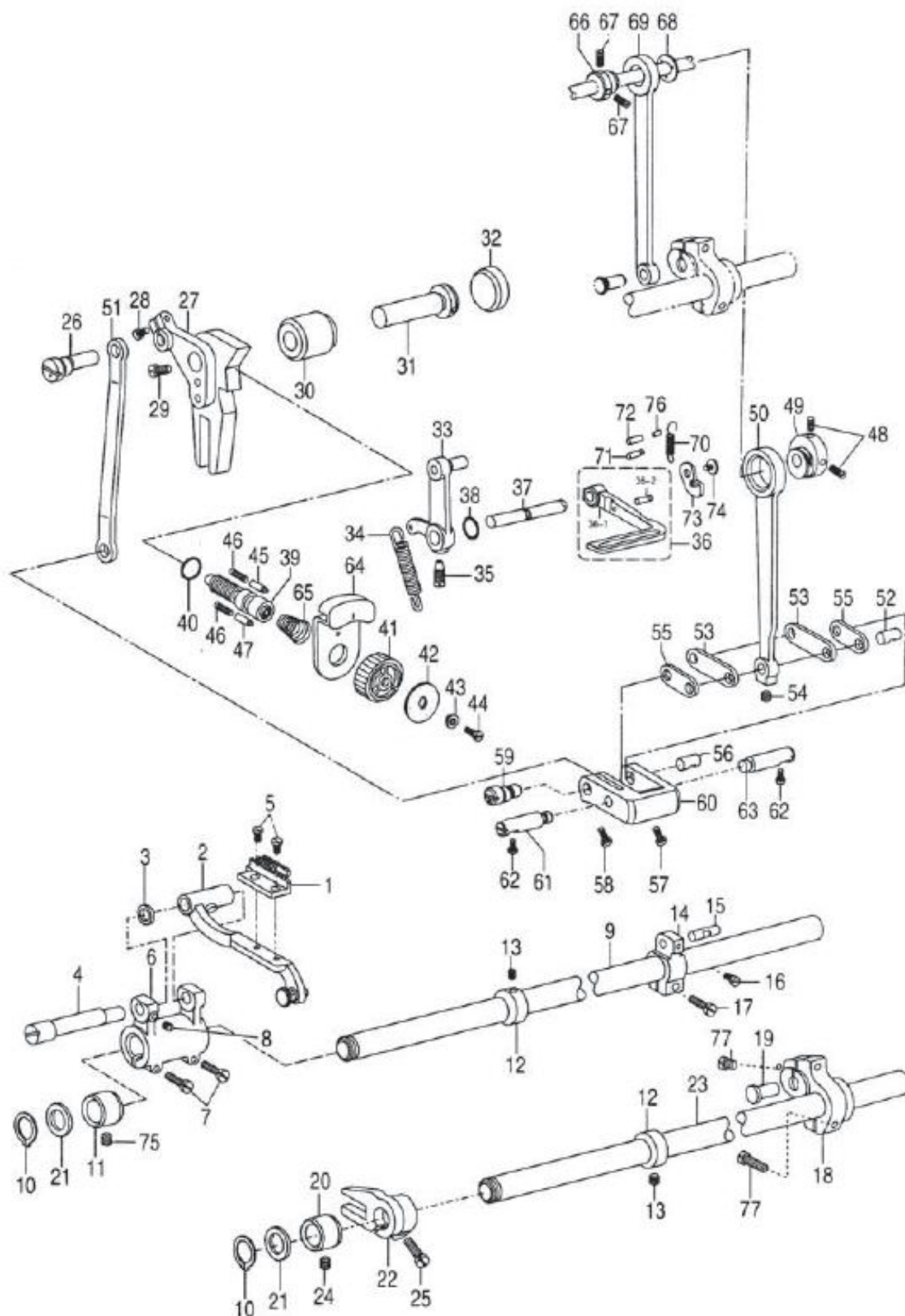

#### 4. 送料部件 Feed mechanism

序号 No.	图 号 Part Number	零件名称 Name		数量 Qt.	
				0303D2	6202D2
46	22T5-009	止动销弹簧	Spring	2	2
47	7WF2-006	针距盘挡销	Stopper pin	1	1
48	36T3-003D <sub>2</sub>	送布凸轮螺钉	Set screw	3	3
49	36T5-008E <sub>1</sub>	送布凸轮	Feed cam	1	1
50	4WF2-009A	送布连杆	Feed connecting rod	1	1
51	4WF2-009B	针距调节连杆	Connecting rod	1	1
52	82T2-003C1a10-1	曲柄连杆长销	Stud	1	1
53	36T5-008E4H02	曲柄长连杆	Link	2	2
54	36T5-008E5	送布连杆螺钉	Set screw	1	1
55	36T5-008E4H01	曲柄短连杆	Link	2	2
56	36T5-008E6	曲柄连杆短销	Shaft	1	1
57	36T5-008E7	短连杆销螺钉	Screw	1	1
58	36T5-008E8	连杆偏心轴螺钉	Screw	1	1
59	36T5-008E9	连杆偏心轴	Shaft	1	1
60	36T5-008E10	针距调节曲柄	Feed regulator crank	1	1
61	5WF1-002	针距调节曲柄定位销(左)	Pin shaft, L	1	1
62	22T6-008D3	左、右定位销螺钉	Screw	2	2
63	5WF1-001	针距调节曲柄定位销(右)	Pin shaft, R	1	1
64	7WF2-005	针距按键	Stopper	1	1
65	36T5-011	针距按键簧	Spring	1	1
66	36T3-003D <sub>1</sub>	抬牙凸轮	Eccentric wheel	1	1
67	36T3-003D <sub>2</sub>	抬牙凸轮螺钉	Screw	3	3
68	36T3-004	凸轮隔离片	Holder	1	1
69	22T3-009D1C	抬牙连杆	Feed lifting rod	1	1
70	2KT3-008	倒缝扳手拉簧	Spring	1	1
71	2KT3-009	弹簧挂销	Spring hook	1	1
72	2KT3-006	倒缝扳手限位销	Pin	1	1
73	2KT3-004	倒缝扳手板	Plate	1	1
74	2KT3-005	倒缝扳手轴螺钉	Screw	1	1
75	J0.0.35	送布轴前轴套螺钉	Screw	1	1
76	2KT3-007	销套	Pin shaft	1	1
77	17WF4-021	抬牙右曲柄螺钉	Screw	1	1

## 5、上送料部件 Upper feed mechanism

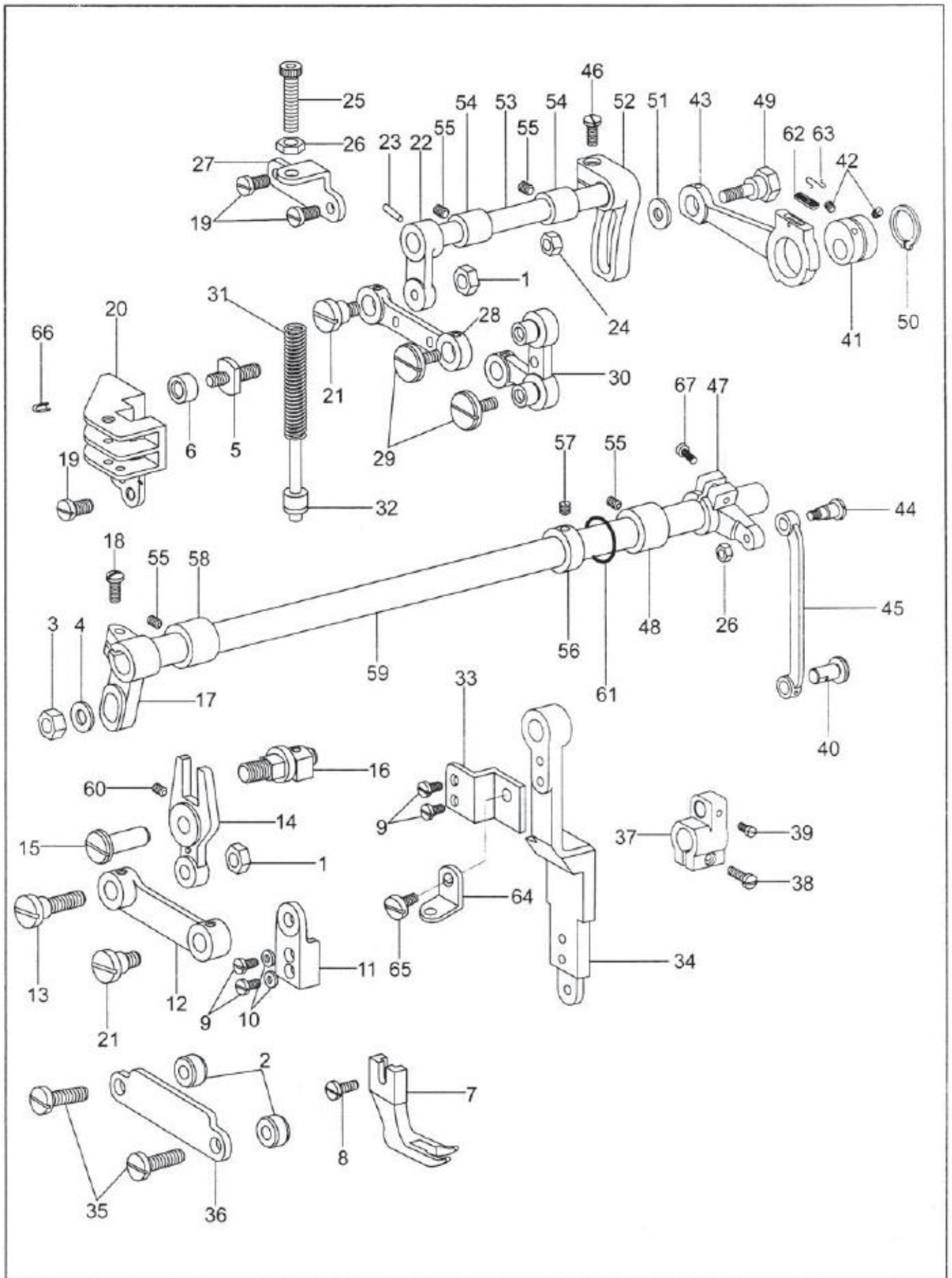

## 5、上送料部件 Upper feed mechanism

序号 No.	图号 Part Number	零件名称 Name		数量 Qt.	
				0303D2	6202D2
1	7WF5-001	压脚送料变动连接螺母	Nut	2	-
2	7WF5-002	压脚连杆压板垫块	Collar	2	-
3	7WF5-003	压脚曲柄连接螺母	Nut	1	-
4		压脚曲柄连接垫圈	Washer	1	-
5	7WF5-004	送料曲柄导柱轴	Roller shaft	1	-
6	7WF5-005	提升压脚导柱轴滚柱	Roller	1	-
7	11WF5-001	摆压脚	Walking foot	1	-
8	61-04-01/B316	压脚螺钉	Screw	1	-
9	7WF5-008	摆动连杆座螺钉	Screw	4	-
10		摆动连杆座螺钉弹簧垫圈	Washer	2	-
11	7WF5-009	摆压脚杆座	Clamper	1	-
12	7WF5-010	摆压脚连杆	Link	1	-
13	7WF5-011	压脚送料变动连接螺钉	Shoulder screw	1	-
14	7WF5-012	摆压脚叉型杆	Lever	1	-
15	7WF5-013	摆压脚叉型杆销	Shaft	1	-
16	7WF5-014A	压脚送料变动曲柄轴组件	Roller shaft assy.	1	-
17	233WF5-023	压脚摆动前曲柄	Crank	1	-
18	1WF4-032	前曲柄螺钉	Screw	2	-
19	22T2-019	提升压脚导位板螺钉	Screw	4	-
20	7WF5-018	提升压脚导位板	Lever guide	1	-
21	7WF5-019	压脚送料曲柄连杆螺钉	Screw	2	-
22	7WF5-020	压脚升降前曲柄	Feed lifting arm crank, L	1	-
23		圆锥销	Pin	1	-
24	7WF5-050	六角螺母	Nut	1	-
25	7WF5-021	摆压脚调压螺钉	Screw	1	-
26	7WF5-022	摆压脚调压螺母	Nut	2	-
27	7WF5-023	摆压脚调压螺钉架	Bracket	1	-
28	7WF5-024	压脚送料曲柄连杆	Link	1	-
29	7WF5-025	压脚送料曲柄螺钉	Screw	2	-
30	258F3-005	压脚送料曲柄	Feed lever	1	-
31	81WF6-003	摆压脚调压杆弹簧	Spring, compression	1	-
32	81WF6-004	调压杆弹簧导柱	Guide shaft	1	-
33	241WF3-001	提升压脚导柱定位板	Holder plate	1	-
34	7WF5-030	摆压脚杆	Connecting rod	1	-
35	22T6-008D <sub>3</sub>	提升压脚连接压板螺钉	Screw	2	-
36	7WF5-031	提升压脚连接压板	Rod guide	1	-
37	5WF4-002	送布轴曲柄(中)	Feed rocker arm	1	-
	258WF3-003	送布轴曲柄(中)	Feed rocker arm	-	-
38	61-04-01/B504	送布轴曲柄(中)螺钉	Screw	1	-
39	36T5-008E <sub>3</sub>	大连杆曲柄连接销钉	Set screw	1	-
40	5WF4-001	大连杆曲柄连接销	Stud	1	-
	258WF3-004	大连杆曲柄连接销		-	-
41	7WF5-032	压脚升降偏心轮	Eccentric wheel	1	-
42	22T2-005B <sub>3</sub>	螺钉	Screw	2	-
43	7WF5-034	连杆组件	Connecting rod	1	-
44	7WF5-037	压脚摆动后曲柄连杆螺钉	Shoulder screw	1	-
45	7WF5-038	摆压脚大连杆	Connecting rod	1	-
	258WF3-002	摆压脚大连杆	Shoulder screw	-	-
46	7WF5-039	偏心连杆调节曲柄螺钉	Feed lifting arm crank, R	1	-
47	241WF3-003	压脚摆动后曲柄	Bush, M	1	-
48	241WF3-005	压脚摆动轴中轴套	Screw	1	-
49	7WF5-042	偏心轮连杆螺钉	Retaining ring, C	1	-
50		轴用C型挡圈	Washer	1	-
51	7WF5-049	垫圈	Washer	1	-
52	7WF5-043	偏心连杆调节曲柄	Feed arm	1	-
53	7WF5-044	压脚升降轴	Feed lifting shaft	1	-
54	7WF5-045	摆压脚提升轴套	Bush	2	-
55	61-04-01/B308	摆动升降轴套支头螺钉	Screw	3	-
56	22T3-002B <sub>1</sub>	压脚摆动轴紧圈	Collar	1	-
57	22T3-002B <sub>2</sub>	压脚摆动轴紧圈螺钉	Screw	2	-
58	1KT2-004	压脚摆动轴前轴套	Bush, L	1	-
59	241WF3-004	压脚摆动轴	Upper feed shaft	1	-
60	7WF5-048	摆压脚叉型杆销螺钉	Screw	1	-
61	33T2-030-A	O型圈	O ring	1	-
62	7WF5-035	偏心轮连杆油毡	Oil felt	1	-
63	1WF5-024	偏心轮连杆油毡压簧	Spring	1	-
64	241WF3-002	提升压脚导柱架	Bracket	1	-
65	241WF3-006	导柱架螺钉	Screw	1	-
66	1WF5-024	弹性圆锥销	Pin	2	-
67	16WF3-031	后曲柄螺钉	Screw	1	-

## 6. 旋梭部件 Hook mechanism

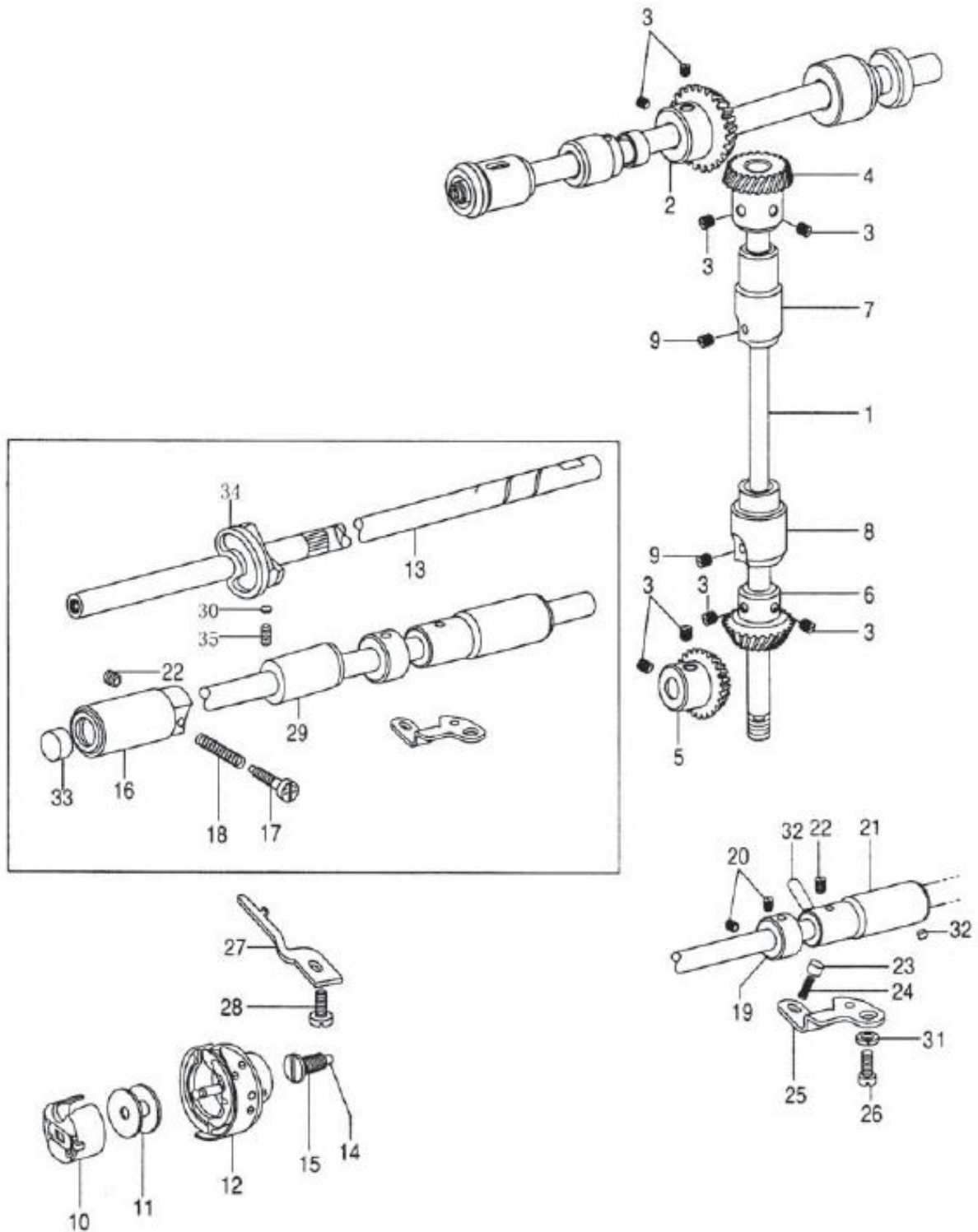

## 6. 旋梭部件 Hook mechanism

序号 No.	图 号 Part Number	零件名称 Name		数量 Qt.	
				0303D2	6202D2
1	15WF1-001	竖轴	Vertical shaft	1	1
2	ZOA140379	上轴伞齿轮	Bevel gear, upper shaft	1	1
3	22T2-005B3	伞齿轮螺钉	Set screw	8	8
4	ZOA140380	竖轴伞齿轮(上)	Bevel gear, vertical shaft, U	1	1
5	ZOA140383	下轴伞齿轮	Bevel gear, lower shaft	1	1
6	ZOA140382	竖轴伞齿轮(下)	Bevel gear, vertical shaft, L	1	1
7	2KT1-015	竖轴上轴套	Bush, vertical shaft, U	1	1
8	2KT1-008	竖轴下轴套	Bush, vertical shaft, L	1	1
9	J0.0.40	竖轴轴套螺钉	Screw	2	2
10	151845001	梭心套组件	Bobbin case	1	1
11	24WF2-001	梭心	Bobbin	1	1
12	159793901	旋梭组件	Hook assy.	1	1
13	122WF3-001	下轴	Lower shaft	1	1
14	22T4-001A1a2	下轴滤油塞	Filter	1	1
15	22T4-001A1a1	下轴滤油塞螺钉	Screw	1	1
16	68WF3-015	下轴前轴套	Bush, lower shaft, L	1	1
17	22T4-005	油量调节螺钉	Adjusting screw, oil	1	1
18	22T4-006	油量调节弹簧	Adjusting spring	1	1
19	22T4-002B1	下轴紧圈	Collar	1	1
20	J0.0.35	下轴紧圈螺钉	Screw	2	2
21	68WF3-002	下轴轴套(右)	Bush, lower shaft, R	1	1
22	J0.0.5	下轴轴套螺钉	Screw	2	2
23	36T4-015	柱塞	Plunger	1	1
24	36T4-016	柱塞弹簧	Spring	1	1
25	22T4-010	挡板	Holder plate	1	1
26	22T9-006	挡板螺钉	Screw	1	1
27	2KT1-013	旋梭定位勾	B/case holder position bracket	1	1
28	22T4-015	旋梭定位勾螺钉	Screw	1	1
29	68WF3-016	下轴中轴套	Bush, lower shaft, M	1	1
30	2KT5-032	切线凸轮螺钉垫片	Trimming cam	1	1
31		挡板螺钉弹簧垫圈	Washer	1	1
32	22T4-007C2	下轴轴套油管	Oil tube	1	1
33	68WF3-014	下轴油封	Oil seal	1	1
34	233WF4-010	切线凸轮	Thred shear cam	1	1
35	2KT5-031	切线凸轮螺钉	Screw	2	2

## 7. 供油润滑部件 Lubrication mechanism

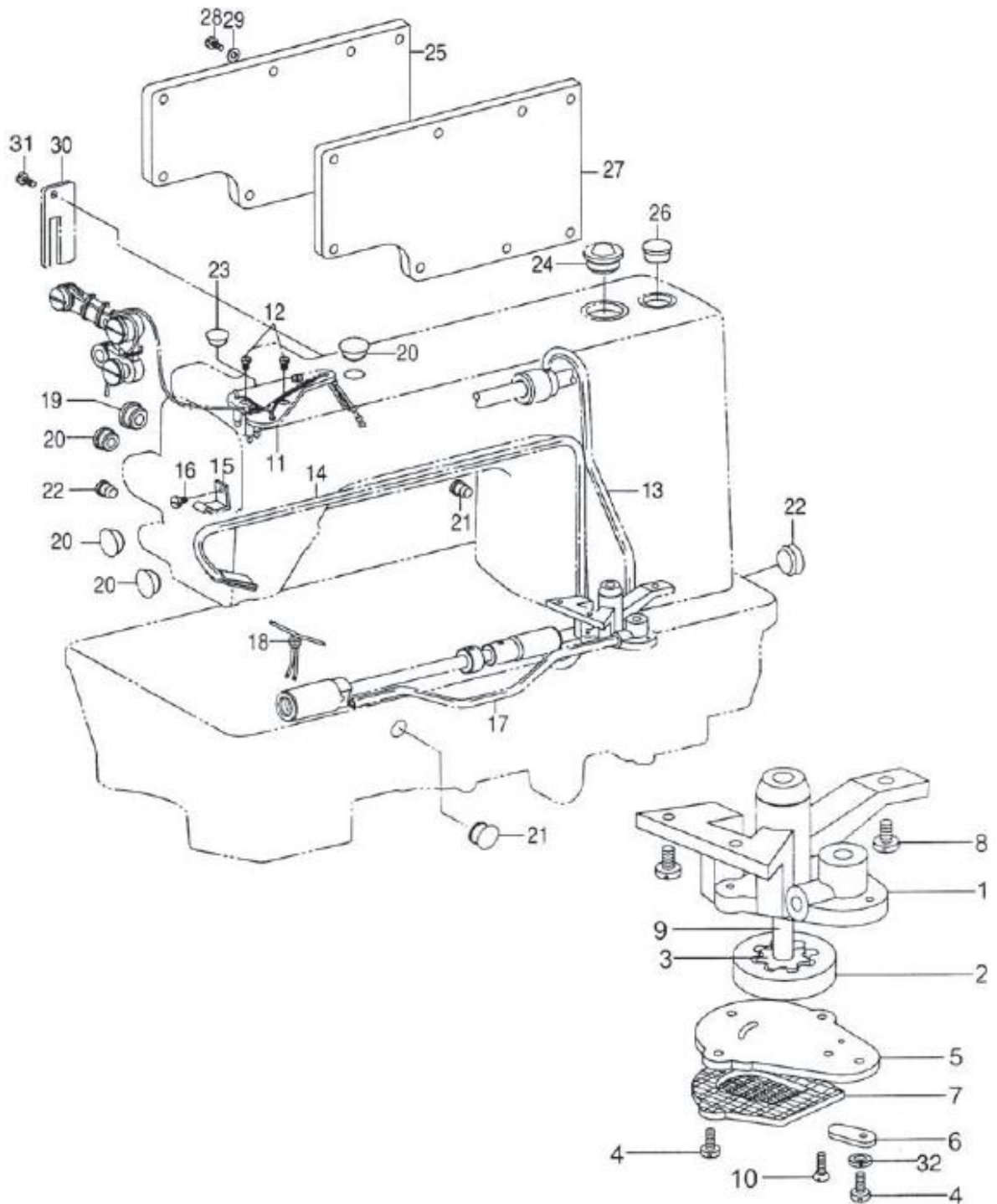



## 7. 供油润滑部件 Lubrication mechanism

序号 No.	图 号 Part Number	零件名称 Name		数量 Qt.	
				0303D2	6202D2
1	15WF4-003	油泵体	Pump body	1	1
2	15WF4-006	油泵大齿轮	Big gear, pump	1	1
3	15WF4-007	油泵小齿轮	Small gear, pump	1	1
4		油泵调节板螺钉	Screw	3	3
5	15WF4-004	油泵体盖板	Cover	1	1
6	22T8-007	油泵调节板	Throat plate	1	1
7	22T8-008A	油泵滤网组件	Filter set	1	1
8	22T8-009	油泵体螺钉	Screw	3	3
9	15WF4-005	油泵体短轴	Shaft	1	1
10		油泵体盖板螺钉	Screw	2	2
11	7WF4-016	油线固定板大组件	Setting plate	1	1
12	22T8-012	油线固定板螺钉	Screw	2	2
13	22T8-013D	上轴油管组件	Oil tube, U	1	1
14	242WF1-004	回油管组件	Tube assy.	1	1
15	22T8-016	回油管夹	Tube carrier	1	1
16	20T4-006	回油管夹螺钉	Screw	1	1
17	122WF5-001	下轴油管组件	Oil tube	1	1
18		油线	Oil wick	1	1
19	22T1-003C3	橡皮塞 (Φ 19)	Rubber cap	1	1
20	22T1-003C4	橡皮塞 (Φ 11.8)	Rubber cap	4	4
21	22T1-015	橡皮塞 (Φ 8.8)	Rubber cap	2	2
22	22T1-016	橡皮塞 (Φ 27)	Rubber cap	1	1
23	22T1-017	橡皮塞 (Φ 5.7)	Rubber cap	1	1
24	22T1-008	油窗组件	Oil gauge window	1	1
25	241WF1-005	后盖板	Back cover	1	1
26	13WF2-035	橡皮塞 (Φ 25.5)	Rubber cap	1	1
27	241WF1-006	后盖板密封垫片	Packing	1	1
28	22T1-006	后盖板螺钉	Screw	8	8
29	22T1-007	后盖板螺钉垫片	Washer	8	8
30	7WF4-011	小挡油板	Oil pan	1	1
31	33T3-006	小挡油板螺钉	Screw	1	1
32		弹簧垫圈	Washer	1	1

## 8.剪线部件 Thread trimming mechanism

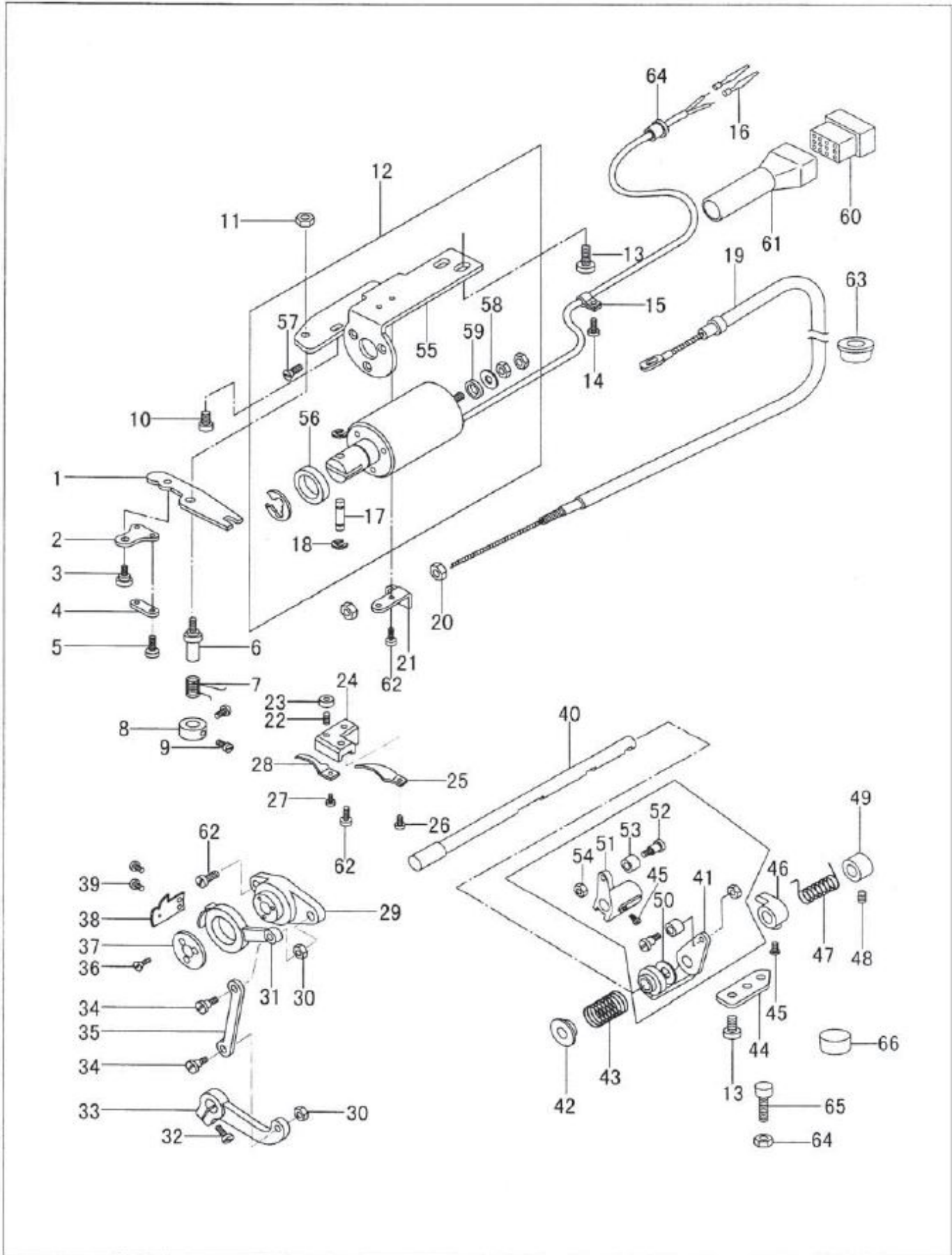

## 8.剪线部件 Thread trimming mechanism

序号 No.	图号 Part Number	零件名称 Name		数量 Qt.	
				0303D2	6202D2
1	78WF1-004	驱动板	Driven plate	1	1
2	78WF1-005	软线支撑板	Wire support	1	1
3	78WF1-006	软线支撑板螺钉	Screw	1	1
4	78WF1-007	软线连板	Link	1	1
5	37T2-203	软线连板螺钉	Screw	1	1
6	78WF1-008	驱动板轴	Screw pin, driven plate	1	1
7	78WF1-009	驱动板弹簧	Spring	1	1
8	78WF1-010	驱动板轴紧圈	Collar	1	1
9	1WF1-024	驱动板轴紧圈螺钉	Screw	2	2
10	22T4-015	安装架连接螺钉	Screw	1	1
11	36WF5-008	驱动轴螺母	Nut	1	1
12	78WF1-001	剪线电磁铁转动组件	Thread trimmer solenoid assy	1	1
13	36WF1-056	安装架固定螺钉	Screw	4	4
14	21WF4-047	线夹螺钉	Screw	1	1
15	84WF1-022	线夹	Wire holder	1	1
16	2KT6-001C	插头接头	Terminal pin	2	2
17	78WF1-001A	剪线电磁铁销	Pin	1	1
18		挡圈	Retaining ring	2	2
19	241WF6-001	松线钢绳组件	Tension release wire	1	-
	258WF6-001	松线钢绳组件	Tension release wire	-	1
20	2KT4-020	软线螺母	Nut	2	2
21	78WF1-012	软线座	Tension release lever	1	1
22	78WF1-013	定刀座螺钉	Screw	1	1
23	78WF1-014	定刀座螺母	Nut	1	1
24	78WF1-015	定刀座	Holder, F-knife	1	1
25	78WF1-016	栏线板	Lower thread finger	1	1
26	2KT6-017	栏线板螺钉	Screw	1	1
27	2KT5-002	定刀片螺钉	Screw	1	1
28	78WF1-002	定刀片	Fixed knife	1	1
29	78WF1-017	刀架	Holder, M-knife	1	1
30	2KT5-013	刀轴连杆螺母	Nut	2	2
31	78WF1-018	刀架(左)	Holder, M-knife, L	1	1
32	22T6-008D3	驱动曲柄螺钉	Screw	1	1
33	78WF1-019	剪线电磁铁驱动曲柄	Driven crank	1	1
34	78WF1-020A	刀架连杆螺钉	Screw	2	2
35	78WF1-020	刀架连杆	Link	1	1
36	78WF1-021	刀架螺钉	Screw	3	3
37	78WF1-022	刀架垫圈	Washer	1	1
38	78WF1-003	动刀片	Movable knife	1	1
39	2KT5-007	动刀片紧固螺钉	Screw	2	2
40	78WF1-023	凸轮曲柄轴	Thread trimmer cam lever shaft	1	1
41	78WF1-024B	切线凸轮右曲柄	Thread trimmer cam lever, R	1	1
42	78WF1-025	扭簧端盖	Collar	1	1
43	78WF1-026	扭簧	Spring	1	1
44	241WF6-002	止动板	Stopper plate	1	1
45	21WF3-010	限位块螺钉	Screw	3	3
46	78WF1-028	限位块	Positioning block	1	1
47	78WF1-029	凸轮轴扭簧	Spring	1	1
48	22T3-002B2	紧圈螺钉	Screw	2	2
49	78WF1-030	凸轮轴紧圈	Collar	1	1
50	78WF1-024F	塑料圈	Plastic ring	1	1
51	78WF1-024A	切线凸轮左曲柄	Thread trimmer cam lever, L	1	1
52	78WF1-024C	滚轮螺钉	Screw	2	2
53	78WF1-024D	滚轮	Roller	2	2
54	78WF1-024E	滚轮螺母	Nut	2	2
55	78WF1-001B	剪线电磁铁安装架	Thread trimmer solenoid base	1	1
56	78WF1-001C	密封垫圈(大)	Seal washer, big	1	1
57		剪线电磁铁紧固螺钉	Screw	3	3
58		平垫片	Washer	1	1
59	78WF1-001D	密封垫圈(小)	Seal washer, small	1	1
60	2KT8-002	插头套	Connector	1	1
61	2KT8-003	线罩	Cover	1	1
62	21WF4-047	螺钉	Screw	4	4
63	78WF1-032	剪线电磁铁电线保护套	Guard	1	1
64		螺母	Nut	1	1
65	241WF6-003	止动螺钉	Screw	1	1
66	241WF6-004	缓冲垫	Packing	1	1

## 9. 倒缝部件 Reverse stitching mechanism

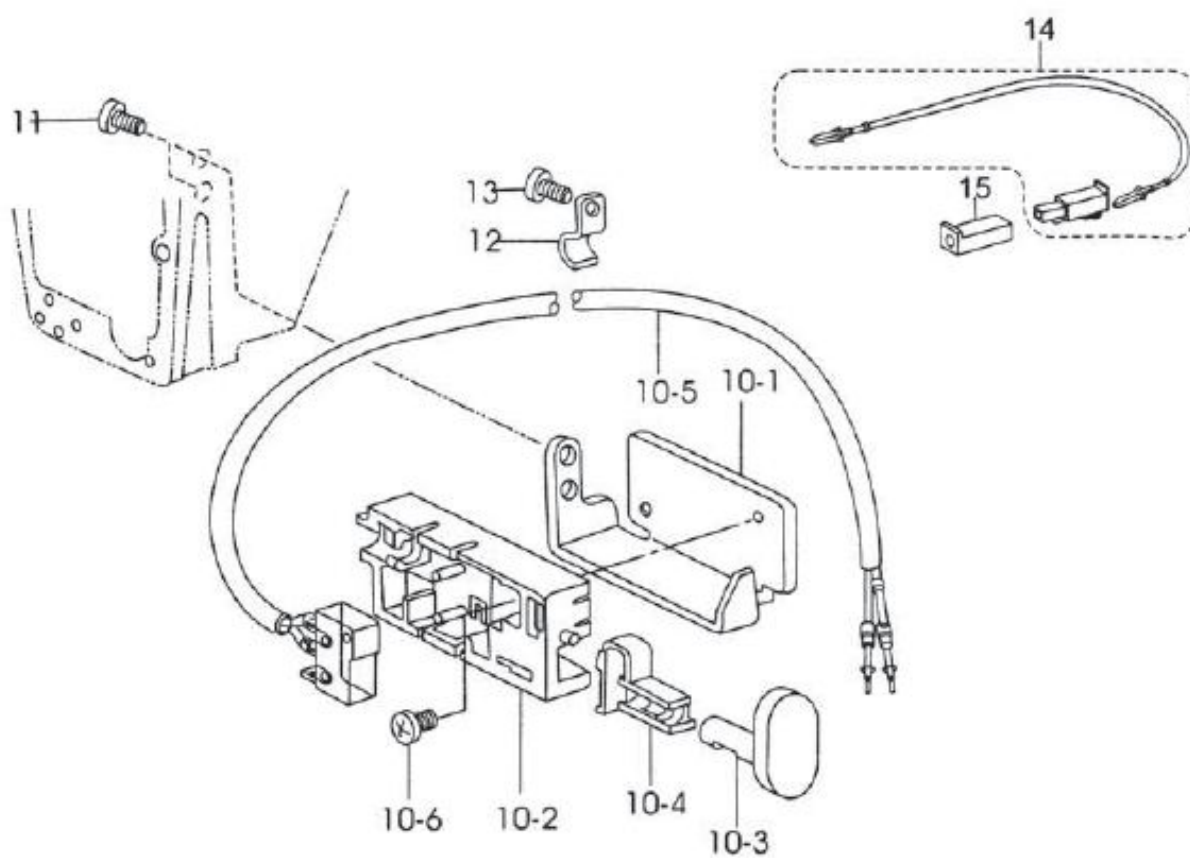
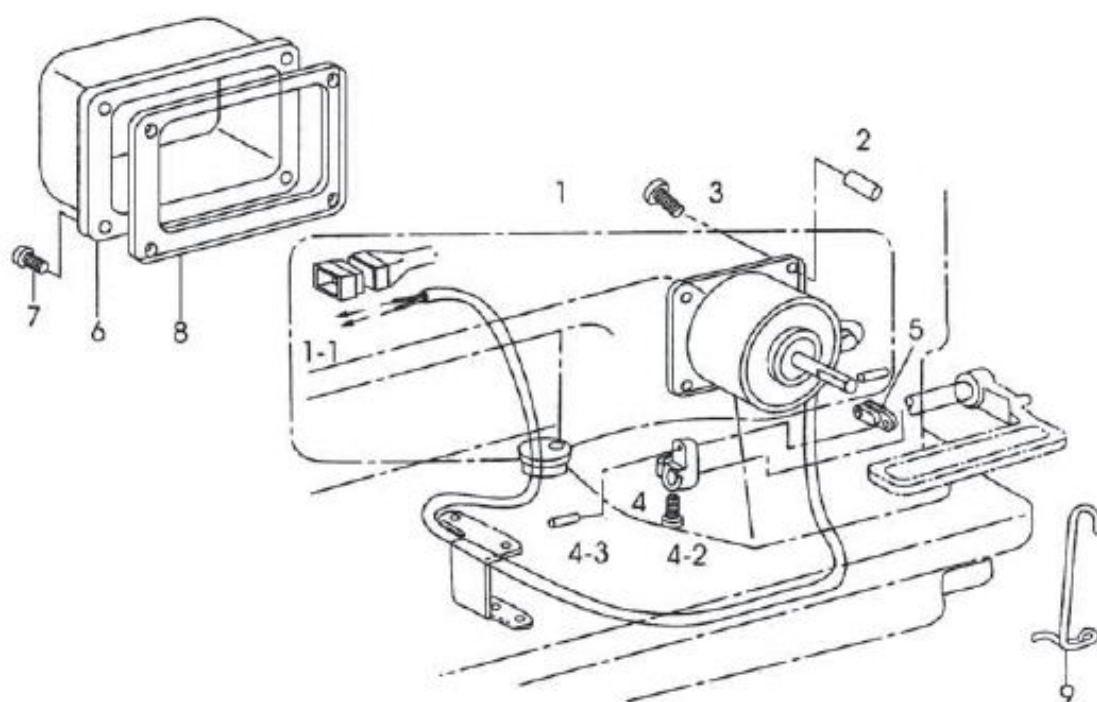

## 9. 倒缝部件 Reverse stitching mechanism

序号 No.	图 号 Part Number	零件名称 Name		数量 Qt.	
				0303D2	6202D2
1	2KT6-001	倒缝电磁铁组件	Quick reverse solenoid assy	1	1
1-1	2KT6-001C	插头	Terminal pin	2	2
2	2KT6-006	衬管	Space collar	4	4
3	2KT6-007	衬管螺钉	Screw	4	4
4-1	2KT6-004	倒缝电磁铁曲柄	Solenoid lever	1	1
4-2	2KT5-015	曲柄螺钉	Screw	1	1
4-3	2KT6-003	倒缝电磁铁曲柄连杆销	Pin	1	1
5	2KT6-002	倒缝电磁铁连杆	Connecting lever	1	1
6	2KT6-008	倒缝电磁铁罩	Solenoid cover	1	1
7	22T1-006	倒缝电磁铁螺钉	Screw	4	4
8	2KT6-009	倒缝电磁铁罩垫片	Washer	1	1
9	2KT3-011	倒缝操纵曲柄弹簧钩	Cord holder	1	1
10-1	2KT6-011	倒缝电磁铁开关安装架	Support	1	1
10-2	2KT6-013	倒缝按键开关座	Base	1	1
10-3	2KT6-015	倒缝按键开关	Actuator	1	1
10-4	2KT6-014	倒缝电磁铁开关触件	Spring, R-switch	1	1
10-5	2KT6-016	倒缝开关组件	Reverse switch assy.	1	1
10-6		倒缝按键开关座螺钉	Screw	1	1
11	2KT6-012	开关安装架螺钉	Screw	2	2
12	2KT5-040	线夹	Cord holder	3	3
13	2KT6-017	线夹螺钉	Screw	3	3
14	2KT6-018	倒缝电磁铁组件	Wire, reverse solenoid	1	1
15	2KT6-019	接头(2)	Connector	1	1

# 10. 0303D-2附件 Accessories

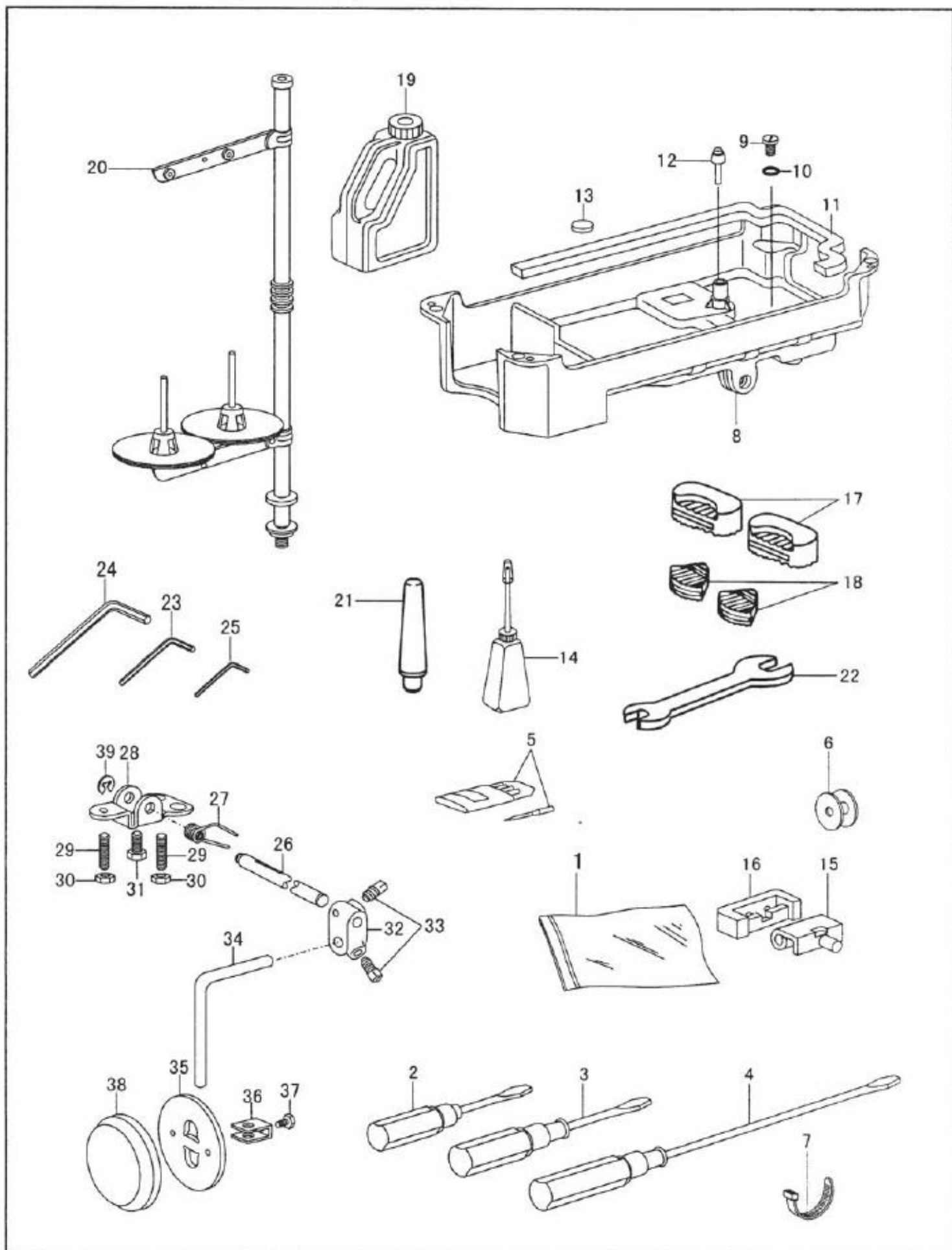

## 10. 0303D-2附件 Accessories

序号 No.	图号 Part Number	零件名称 Name		数量 Qt.
				0303D2
1	33TF-010	零件袋	Accessory bag	1
2	33TF-014	一字开刀 (小)	Screw driver, S	1
3	33TF-013	一字开刀 (中)	Screw driver, M	1
4	33TF-012	一字开刀 (大)	Screw driver, L	1
5		机针	Needle	4
6	24WF2-001	梭芯	Bobbin	3
7	129WF1-016	捆扎带	Bobbin thread winder assy.	3
8	122WF7-005	油盘	Screw	1
9	22T9-001A2	放油螺钉	Washer	1
10	22T9-001A3	放油螺钉垫圈	Belt guard assy.	1
11	2KT9-008	油盘垫	Screw	1
12	4WF5-002	膝控提升顶杆	Washer	1
13	22T9-012	磁块	Screw	1
14	33TF-011	油壶	Oil pot	1
15	22T9-007F1	机壳铰链	Head hinge	2
16	22T9-007F2	机壳铰链套	Cushion, head hinge	2
17	1KT5-004	机头防震垫块 (大)	Head cushion, L	2
18	1KT5-003	机头防震垫块 (小)	Head cushion, S	2
19	1F-012	油箱	Oil tank	1
20	4F-007	线架组件	Thread stand assy.	1
21	1KT5-007	机头撑杆	Head rest	1
22		呆扳手	Wrench	1
23		2mm内六角扳手	Wrench, 2mm	1
24		3mm内六角扳手	Wrench, 3mm	1
25		2.5mm内六角扳手	V-belt	1
26	22T9-001A6	膝控铰链轴	Lifter shaft	1
27	22T9-001A7	膝控复位弹簧	Spring	1
28	22T9-001A8	膝控限位架	Bracket	1
29	22T9-001A9	膝控限位调节螺钉	Adjusting screw	2
30	22T9-001A10	调节螺母	Adjusting nut	2
31	22T9-036	膝控限位架螺钉	Screw	1
32	22T9-003B3	碰块弯杆接头	Bracket	1
33		碰块弯杆接头螺钉	Screw	各1
34	22T9-003B2	膝控碰块弯杆	Lifter bar	1
35	22T9-003B5	膝控碰块	Knee lifter plate	1
36	22T9-003B6	碰块架	Stopper	1
37	22T9-003B7	碰块架螺钉	Screw	1
38	22T9-003B8	碰块垫	Cover, K-lifter plate	1
39		开口挡圈	Retaining ring	1

# 11. 202D2 附件 Accessories

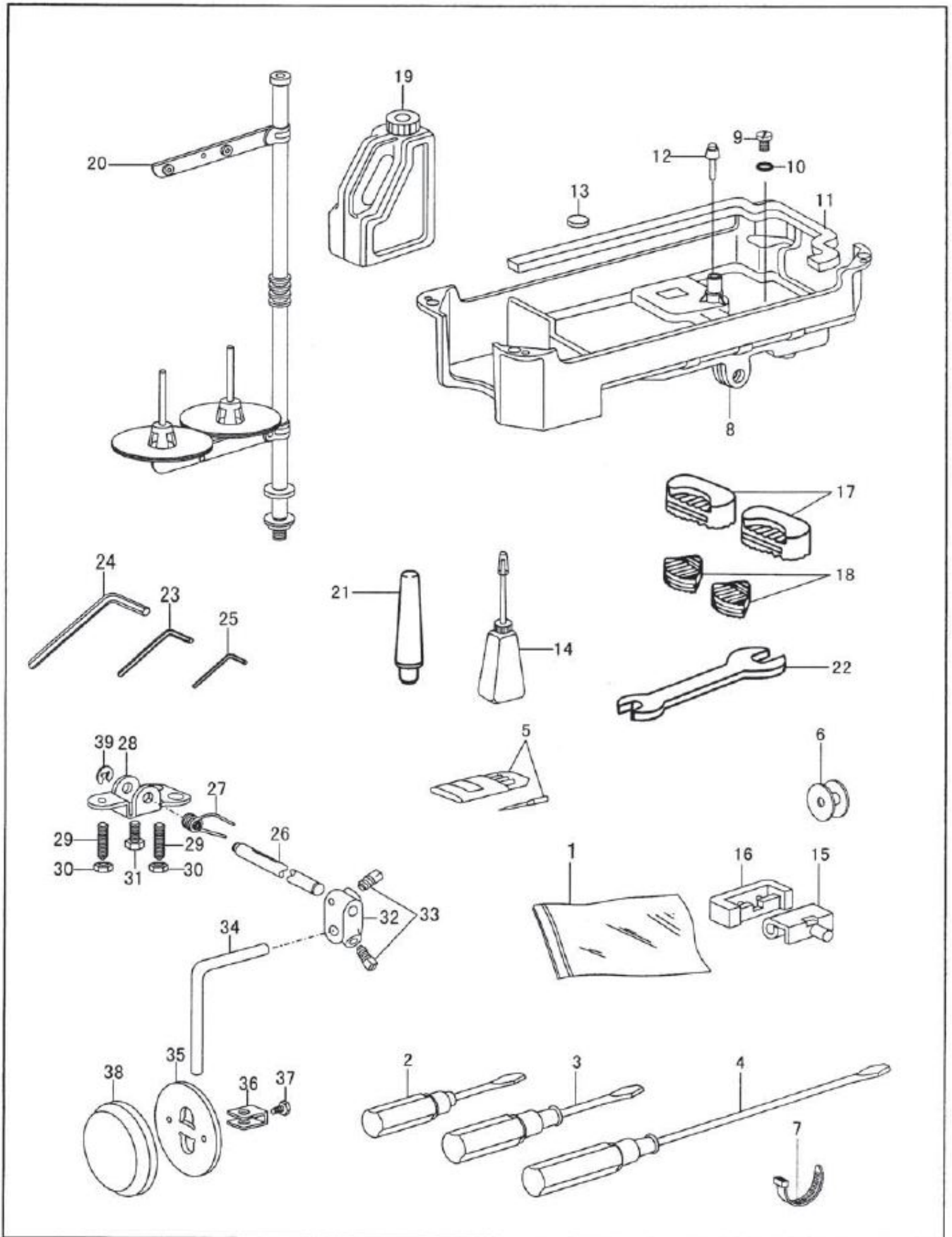



## 11. 202D2 附件 Accessories

序号 No.	图号 Part Number	零件名称 Name		数量 Qt.
				6202D2
1	33TF-010	零件袋	Accessory bag	1
2	33TF-014	一字开刀 (小)	Screw driver, S	1
3	33TF-013	一字开刀 (中)	Screw driver, M	1
4	33TF-012	一字开刀 (大)	Screw driver, L	1
5		机针	Needle	4
6	24WF2-001	梭芯	Bobbin	3
7	129WF1-016	捆扎带	Bobbin thread winder assy.	3
8	122WF7-005	油盘	Screw	1
9	22T9-001A2	放油螺钉	Washer	1
10	22T9-001A3	放油螺钉垫圈	Belt guard assy.	1
11	2KT9-008	油盘垫	Screw	1
12	4WF5-002	膝控提升顶杆	Washer	1
13	22T9-012	磁块	Screw	1
14	33TF-011	油壶	Oil pot	1
15	22T9-007F1	机壳铰链	Head hinge	2
16	22T9-007F2	机壳铰链套	Cushion, head hinge	2
17	1KT5-004	机头防震垫块 (大)	Head cushion, L	2
18	1KT5-003	机头防震垫块 (小)	Head cushion, S	2
19	1F-012	油箱	Oil tank	1
20	4F-007	线架组件	Thread stand assy.	1
21	1KT5-007	机头撑杆	Head rest	1
22		呆扳手	Wrench	1
23		2mm内六角扳手	Wrench, 2mm	1
24		3mm内六角扳手	Wrench, 3mm	1
25		2.5mm内六角扳手	V-belt	1
26	22T9-001A6	膝控铰链轴	Lifter shaft	1
27	22T9-001A7	膝控复位弹簧	Spring	1
28	22T9-001A8	膝控限位架	Bracket	1
29	22T9-001A9	膝控限位调节螺钉	Adjusting screw	2
30	22T9-001A10	调节螺母	Adjusting nut	2
31	22T9-036	膝控限位架螺钉	Screw	1
32	22T9-003B3	碰块弯杆接头	Bracket	1
33		碰块弯杆接头螺钉	Screw	2
34	22T9-003B2	膝控碰块弯杆	Lifter bar	1
35	22T9-003B5	膝控碰块	Knee lifter plate	1
36	22T9-003B6	碰块架	Stopper	1
37	22T9-003B7	碰块架螺钉	Screw	1
38	22T9-003B8	碰块垫	Cover, K-lifter plate	1
39		开口挡圈	Retaining ring	1