

NO : 8810D001

# 金輪牌工業用縫紉機

GOLDEN WHEEL INDUSTRIAL SEWING MACHINE

## 零件分解圖

PARTS BOOK

① 2017. 04. 26 P02. P16. P18  
② 2018. 02. 08 P08  
③ 2019. 06. 11 P06. P08. P16  
P18. P20. P24.

MODEL:CS-8810D

CS-8820D

CS-8810GD

CS-8820GD

啟翔股份有限公司

CHEE SIANG INDUSTRIAL CO., LTD.

# MODEL : CS-8810D、8820D

索引	INDEX	PAGE
A、外觀零件	MISCELLANEOUS COVER	2-3
B、縫線壓力調節機構	UPPER THREAD TENSION REGULATOR MECHANISM	4-5
C、上送料輪機構	UPPER FEED WHEEL MECHANISM	6-7
D、上軸與天秤機構	UPPER SHAFT & TAKE-UP LEVER MECHANISM	8-9
E、針棒機構	NEEDLE BAR MECHANISM	10-11
F、押棒機構	PRESSER FOOT BAR MECHANISM	12-13
G、擺動軸機構	ROCKING SHAFT MECHANISM	14-15
H、縫目調整器機構	STITCH REGULATOR MECHANISM	16-17
I、送料機構	FEEDING MECHANISM	18-19
J、左邊邊座機構(一)	LEFT SIDE POST MECHANISM (1)	20-21
K、左邊邊座機構(二)	LEFT SIDE POST MECHANISM (2)	22-23
L、右邊邊座機構(一)	RIGHT SIDE POST MECHANISM (1)	24-25
M、右邊邊座機構(二)	RIGHT SIDE POST MECHANISM (2)	26-27
N、附件	ACCESSORIES	28-29
O、針位圖號詳表	GAUGE PARTS LIST	30
P、零件號碼與頁數對照表	NUMERICAL PARTS-LIST	31-34

符號說明:		
(8810)	單針型	Single Needle Type
(8820)	雙針型	Two Needle Type
(D)	直驅馬達	Direct Drive Motor
(G)	大旋梭	Large Hook

# A.CS-8810D/8820D 外觀零件 MISCELLANEOUS COVERS

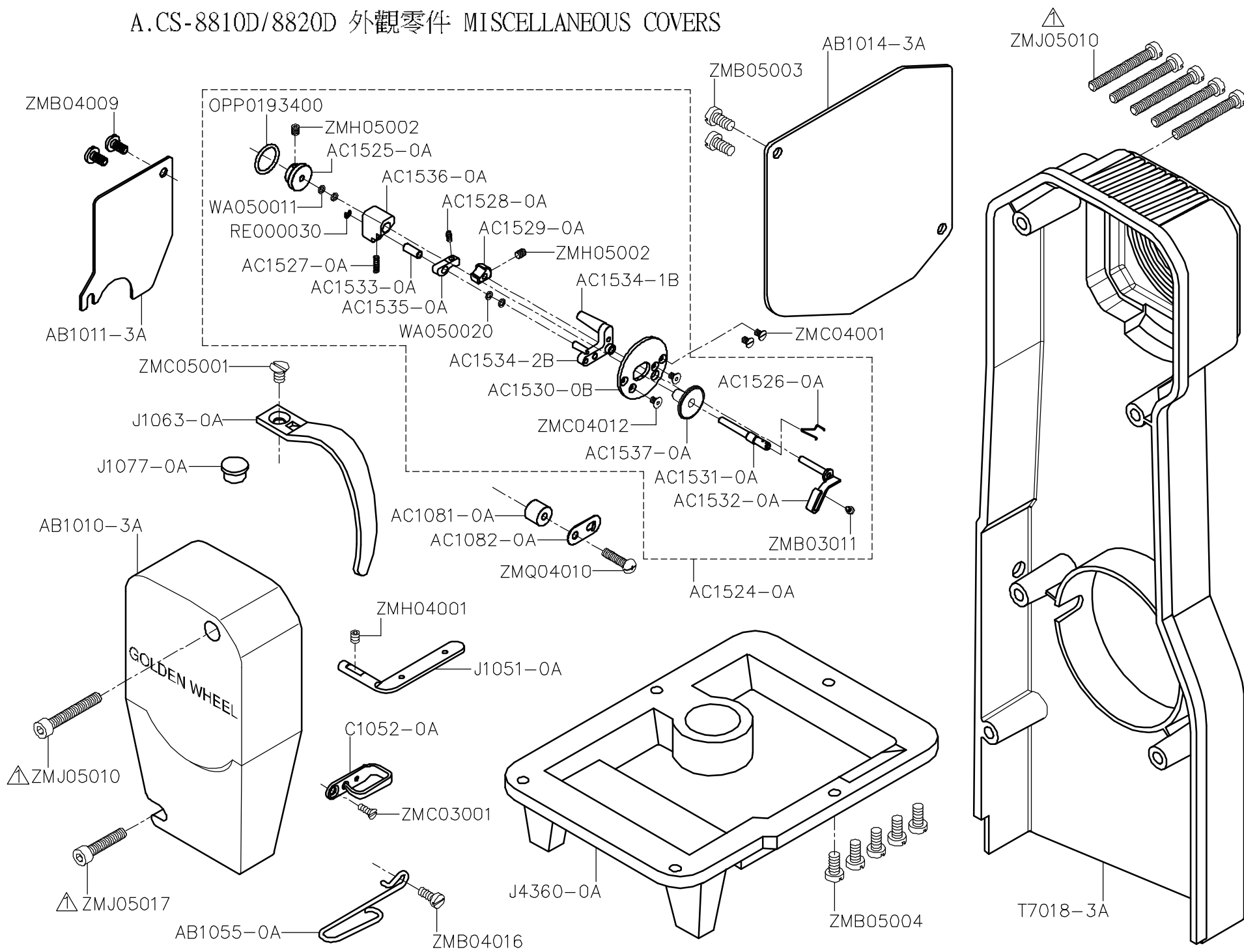

A、CS-8810D、8820D 外觀零件 MISCELLANEOUS COVER

零件號碼 Part No	零件名稱	Name of Part	件數 Q, TY	零件號碼 Part No	零件名稱	Name of Part	件數 Q, TY
AB1010-3A	面板蓋	Face Plate	1	OPP0193400	O形環	O-ring	1
AB1011-3A	小防砂板	Side Cover	1	RE000030	E扣環	E-ring	1
AB1014-3A	後蓋板	Rear Cover	1	T7018-3A	馬達蓋	Motor Cover	1
AB1055-0A	線掛	Thread Guide	1	WA050011	墊圈	Washer	2
AC1081-0A	刀片墊塊	Spacer	1	WA050020	墊圈	Washer	2
AC1082-0A	割線刀	Knife	1	ZMB03011	螺絲	Screw (M3-0.5x8)	1
AC1524-0A	捲線器組	Bobbin Winder Assy.	1	ZMB04009	螺絲	Screw (M4-0.7x6)	2
AC1525-0A	繞線驅動輪	Winder Driving Wheel	1	ZMB04016	螺絲	Screw (M4-0.7x10)	1
AC1526-0A	夾梭子彈簧	Spring	1	ZMB05003	螺絲	Screw (M5-0.8x7)	2
AC1527-0A	壓縮彈簧	Compression Spring	1	ZMB05004	螺絲	Screw (M5-0.8x10)	5
AC1528-0A	壓縮彈簧	Compression Spring	1	ZMB05017	螺絲	Screw (M5-0.8x20)	1
AC1529-0A	制動凸輪	Tripping Cam	1	ZMC03001	螺絲	Screw (M3-0.5x8.5)	1
AC1530-0B	捲線器基板	Bobbin Winder Base	1	ZMC04001	螺絲	Screw (M4-0.7x8.5)	2
AC1531-0A	捲線軸	Bobbin Winder Shaft	1	ZMC04012	螺絲	Screw (M4-0.7x8)	2
AC1532-0A	推桿組	Controlling Lever	1	ZMC05001	螺絲	Screw (M5-0.8x8)	1
AC1533-0A	空心軸	Hollow Shaft	1	ZMH04001	螺絲	Screw (M4-0.7x4)	1
AC1534-1B	捲線器支架	Bobbin Winder Support	1	ZMH05002	螺絲	Screw (M5-0.8x6)	2
AC1534-2B	支架軸	Support Shaft	1	ZMJ05017	螺絲	Screw (M5-0.8x25)	1
AC1535-0A	制爪	Tripping Paw	1	ZMJ05010	螺絲	Screw (M5-0.8x35)	6
AC1536-0A	輪軸架	Shaft Holder	1	ZMQ04010	螺絲	Screw (M4-0.7x16)	1
AC1537-0A	梭子座	Bobbin Seat	1				
C1052-0A	線掛	Thread Guide Wire	1				
J1051-0A	線掛	Thread Guide Wire	1				
J1063-0A	天秤蓋	Thread Take-up Cover	1				
J1077-0A	油蓋	Needle Bar Upper Bushing Cap	1				
J4360-0A	底座盤	Bottom Cover	1				

B.CS-8810D/8820D 縫線壓力調整機構 UPPER THREAD TENSION REGULATOR MECHANISM

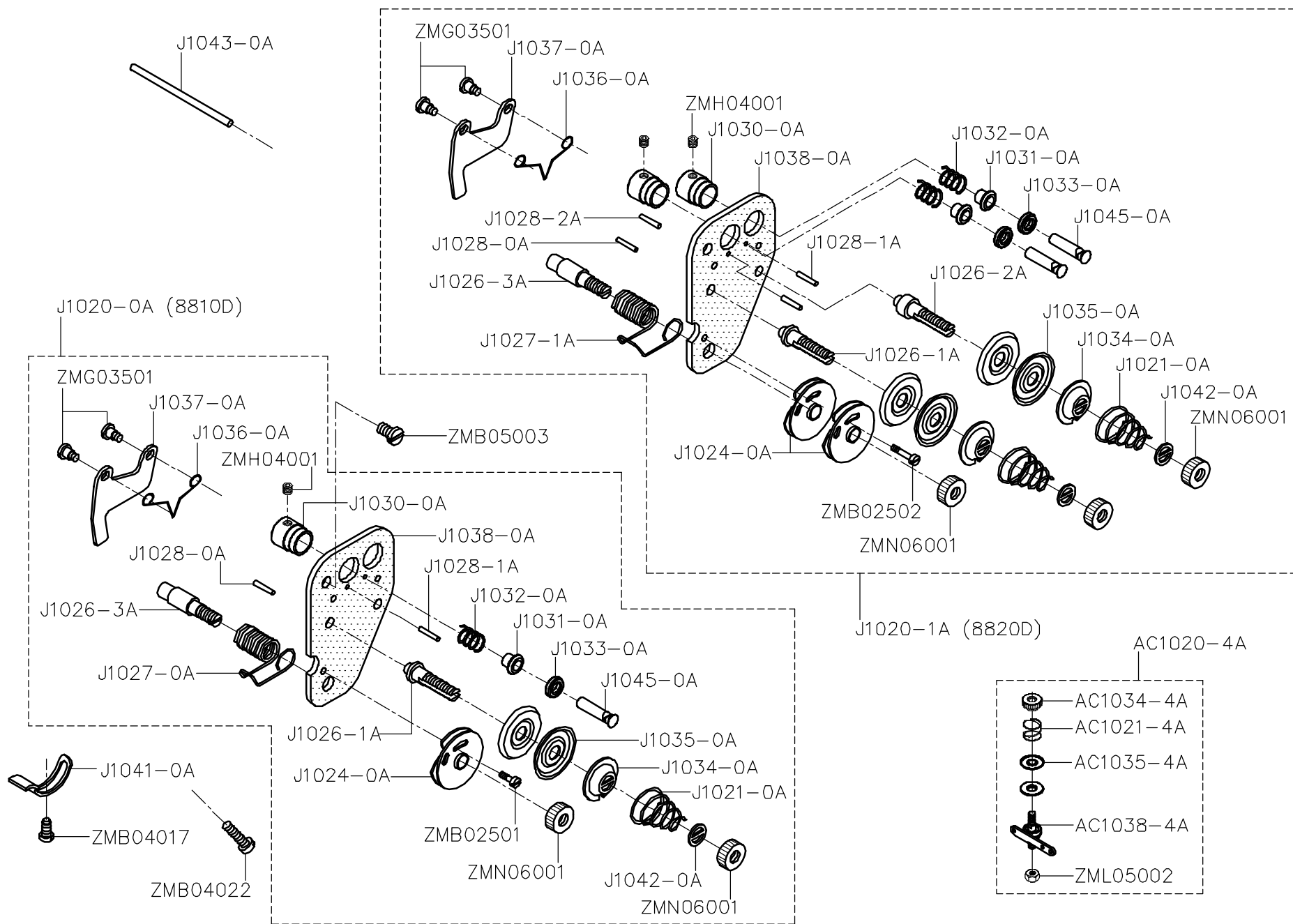

B、CS-8810D、8820D 縫線壓力調節機構 UPPER THREAD TENSION REGULATOR MECHANISM

零件號碼 Part No	零件名稱 Name of Part	件數 Q, TY	零件號碼 Part No	零件名稱 Name of Part	件數 Q, TY
AC1020-4A	沙拉組 ----- Thread Tension Regulator Assy. ----	1	ZMB02501	螺絲 ----- Screw (M2.5-0.45x7) -----	1
AC1021-4A	沙拉組彈簧 --- Tension Spring -----	1	ZMB02502	螺絲 ----- Screw (M2.5-0.45x3) -----	1
AC1034-4A	沙拉組螺帽 --- Adjusting Nut -----	1	ZMB04017	螺絲 ----- Screw (M4-0.7x7) -----	1
AC1035-4A	壓線盤 ----- Thread Guide Disk -----	2	ZMB04022	螺絲 ----- Screw (M4-0.7x7) -----	1
AC1038-4A	線掛組 ----- Thread Guide Assembly -----	1	ZMB05003	螺絲 ----- Screw (M5-0.8x7) -----	1
J1020-0A	縫線壓力調整組 Thread Tension Regulator Assy. ----	1	ZMG03501	螺絲 ----- Hinge Screw -----	2
J1020-1A	縫線壓力調整組 Thread Tension Regulator Assy. ----	1	ZMH04001	螺絲 ----- Screw (M4-0.7x4) -----	2
J1021-0A	調整彈簧 ----- Thread Tension Spring -----	2	ZML05002	螺帽 ----- Nut -----	1
J1024-0A	過線盤組 ----- Tension Regulator Bracket -----	2	ZMN06001	螺帽 ----- Nut -----	3
J1026-1A	調整螺絲棒 --- Thread Tension Stud -----	1			
J1026-2A	調整螺絲棒 --- Thread Tension Stud -----	1			
J1026-3A	調整螺絲棒 --- Thread Tension Stud -----	1			
J1027-0A	吊線彈簧 ----- Thread Take-up Spring -----	1			
J1027-1A	吊線彈簧 ----- Thread Take-up Spring -----	1			
J1028-0A	鬆線銷 ----- Tension Releasing Pin -----	1			
J1028-1A	鬆線銷 ----- Tension Releasing Pin -----	1			
J1028-2A	鬆線銷 ----- Tension Releasing Pin -----	2			
J1030-0A	過線孔台 ----- Thread Guide Bracket -----	2			
J1031-0A	過線孔圓盤 --- Thread Guide Disc -----	2			
J1032-0A	導線架彈簧 --- Thread Tension Spring -----	2			
J1033-0A	過線孔內蓋 --- Controller Cover -----	2			
J1034-0A	線調整壓盤 --- Tension Regulator presser Disc ----	2			
J1035-0A	壓力板 ----- Tension Disc -----	4			
J1036-0A	壓板彈簧 ----- Tension Releasing Spring -----	1			
J1037-0A	彈簧板 ----- Tension Release Plate -----	1			
J1038-0A	上線壓力板 --- Upper Release Plate -----	1			
J1041-0A	線軸彈簧調整器 Stopper -----	1			
J1042-0A	墊片 ----- Washer -----	2			
J1043-0A	鬆線銷 ----- Tension Releasing pin -----	1			
J1045-0A	過線軸 ----- Shaft -----	2			

# C.CS-8810D/8820D 上送料輪機構 UPPER FEED WHEEL MECHANISM

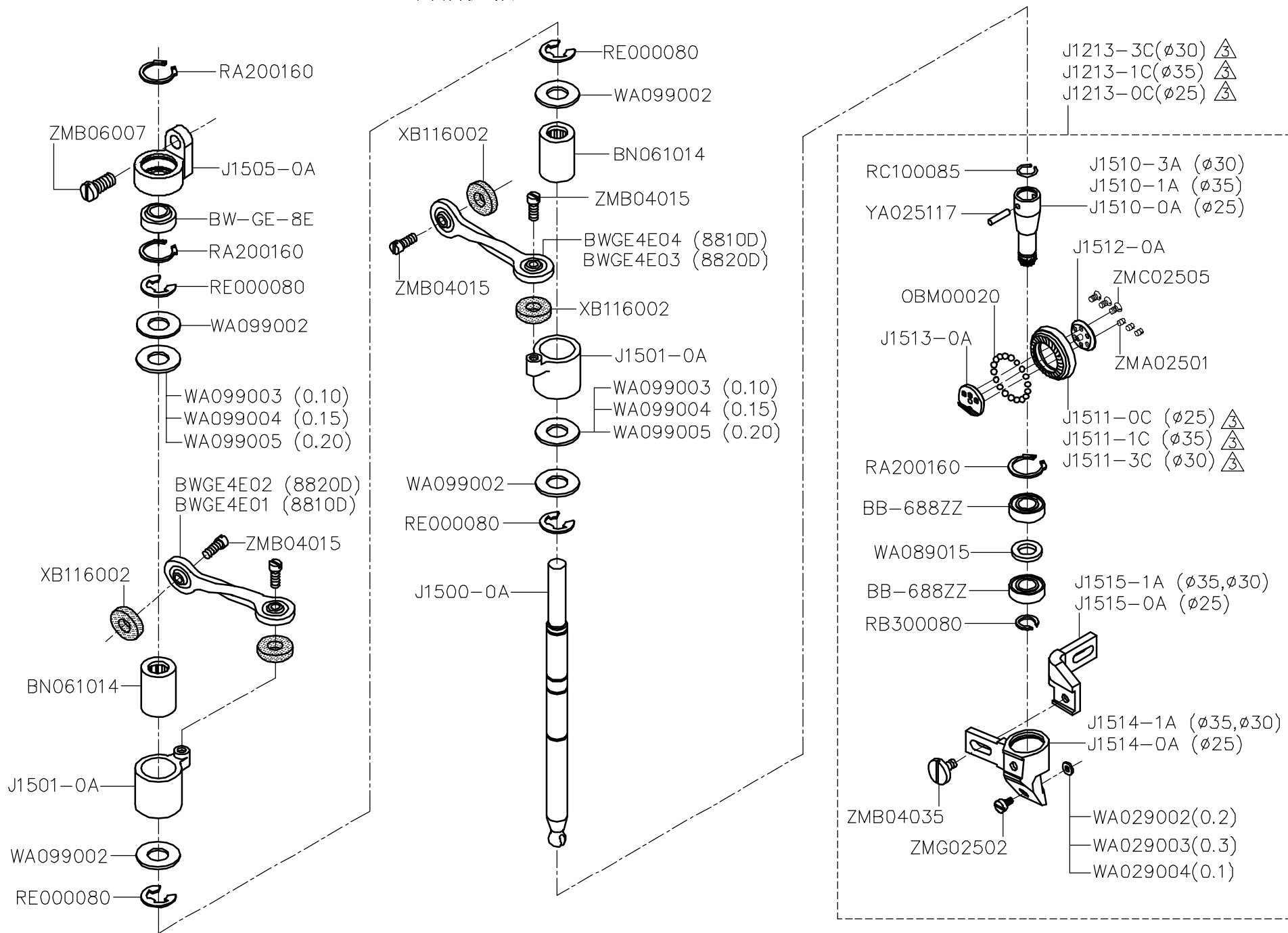

C、CS-8810D、8820D 上送料輪機構 UPPER FEED WHEEL MECHANISM

零件號碼 Part No	零件名稱	Name of Part	件數 Q, TY	零件號碼 Part No	零件名稱	Name of Part	件數 Q, TY
BB-688ZZ	滾珠軸承	Ball Bearing	2	OBM00020	鋼珠(2m/m)	Ball	18
BN061014	針狀軸承	Needle Bearing	2	RA200160	C形扣環	C-ring	3
BW-GE-8E	球狀萬向軸承	Bearing	1	RB300080	C形扣環	C-ring	1
BWGE4E01	球狀萬向軸承拉桿	Link	1	RC100085	止輪環	Spring Washer	1
BWGE4E02	球狀萬向軸承拉桿	Link	1	RE000080	E形扣環	E-ring	4
BWGE4E03	球狀萬向軸承拉桿	Link	1	WA029002	墊圈(0.2)	Washer	1
BWGE4E04	球狀萬向軸承拉桿	Link	1	WA029003	墊圈(0.3)	Washer	1
J1213-0C	輪錢組(ø25)	Roller Presser Assy. (ø25)	1	WA029004	墊圈(0.1)	Washer	1
J1213-1C	輪錢組(ø35)	Roller Presser Assy. (ø35)	1	WA089015	墊圈	Washer	1
J1213-3C	輪錢組(ø30)	Roller Presser Assy. (ø30)	1	WA099002	墊圈	Washer	4
J1500-0A	單向培林軸	Shaft	1	WA099003	墊圈(0.10)	Washer	2
J1501-0A	單向培林座	Free-Wheeling	2	WA099004	墊圈(0.15)	Washer	2
J1505-0A	單向培林座	Bearing Bracket	1	WA099005	墊圈(0.20)	Washer	2
J1510-0A	齒輪	Gear	1	XB116002	油棉	Oil Felt	2
J1510-1A	齒輪	Gear	1	YA025117	平行銷	Pin	1
J1510-3A	齒輪	Gear	1	ZMA02501	螺絲	Screw (M2.5-0.45x2)	3
J1511-0C	車輪	Presser	1	ZMB04015	螺絲	Screw (M4-0.7x8.5)	4
J1511-1C	車輪	Presser	1	ZMB04035	螺絲	Screw (M4-0.7x8)	1
J1511-3C	車輪	Presser	1	ZMB06007	螺絲	Screw (M6-1.0x13)	1
J1512-0A	輪錢軸座(前)	Presser Shaft Seat (Front)	1	ZMC02505	螺絲	Screw (M2.5-0.45x4.8)	3
J1513-0A	輪錢軸座(後)	Presser Shaft Seat (Back)	1	ZMG02502	螺絲	Screw (M2.5-0.45x5.7)	1
J1514-0A	輪錢座	Roller Presser Bracket	1				
J1514-1A	輪錢座	Roller Presser Bracket	1				
J1515-0A	輪錢連接座	Guide Seat	1				
J1515-1A	輪錢連接座	Guide Seat	1				



# D.CS-8810D/8820D 上軸與天秤機構 UPPER SHAFT & TAKE-UP LEVER MECHANISM

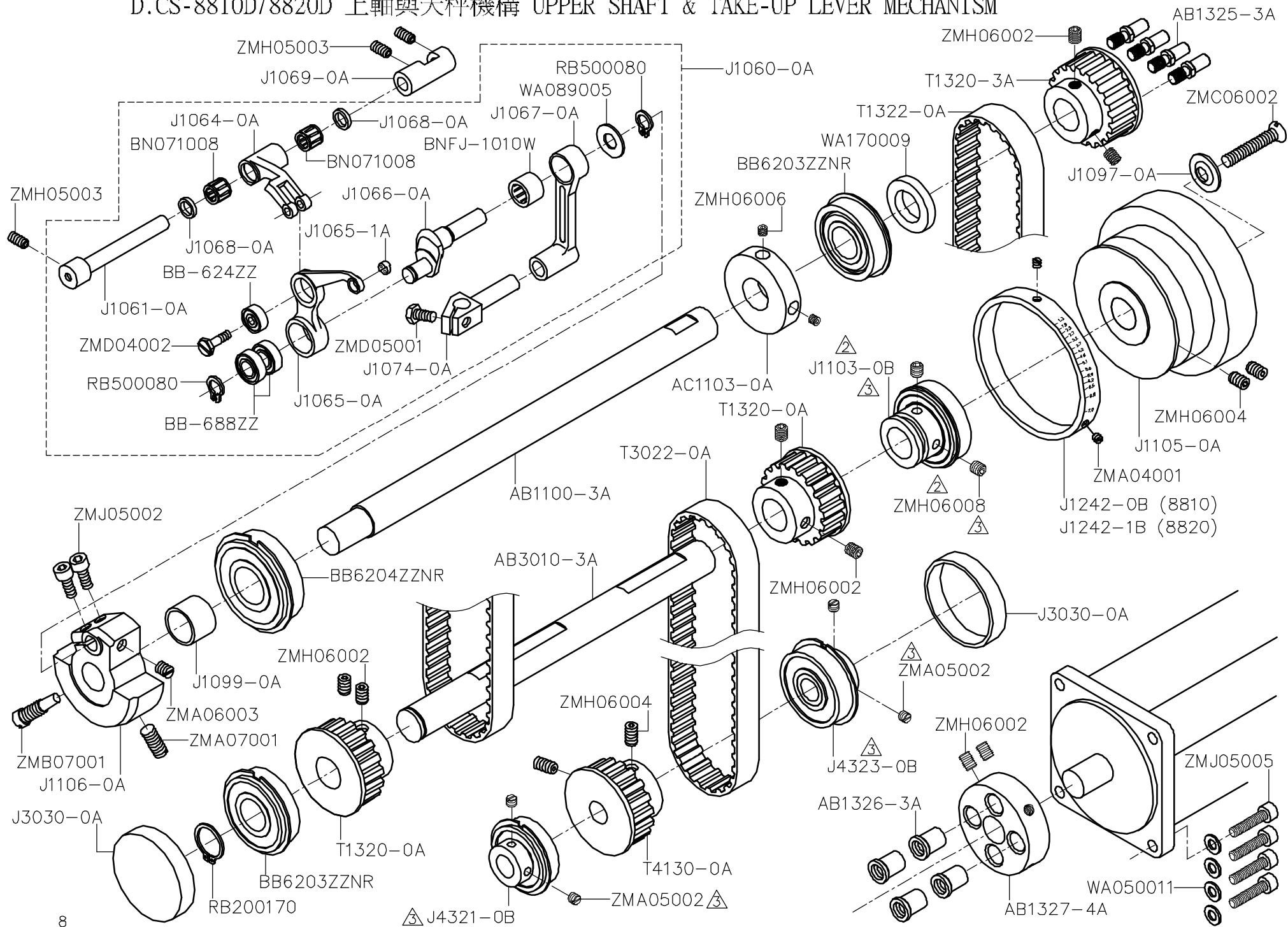

D、CS-8810D、8820D 上軸與天秤機構 UPPER SHAFT & TAKE-UP LEVER MECHANISM

零件號碼 Part No	零件名稱	Name of Part	件數 Q, TY	零件號碼 Part No	零件名稱	Name of Part	件數 Q, TY
AB1100-3A	上軸	Upper Shaft	1	J4323-0B	軸承套管(右)	Collar (Right)	1
AB1325-3A	螺柱	Stud	4	RB200170	C扣環	C-ring	1
AB1326-3A	橡膠套	Rubber	4	RB500080	C扣環	C-ring	2
AB1327-4A	聯軸器	Coupling	1	T1320-0A	齒型皮帶輪	Timing Belt Wheel	2
AB3010-3A	皮帶輪軸	Shaft	1	T1320-3A	齒型皮帶輪	Timing Belt Wheel	1
AC1103-0A	定環	Collar	1	T1322-0A	齒型皮帶	Timing Belt	1
BB-624ZZ	滾珠軸承	Ball Bearing	1	T3022-0A	齒型皮帶	Timing Belt	1
BB-688ZZ	滾珠軸承	Ball Bearing	2	T4130-0A	齒型皮帶輪	Timing Belt Wheel	1
BB6203ZZNR	滾珠軸承	Ball Bearing	2	WA050011	墊圈	Washer	4
BB6204ZZNR	滾珠軸承	Ball Bearing	1	WA089005	墊圈	Washer	1
BN071008	針狀軸承	Needle Bearing	2	WA170009	墊圈	Washer	1
BNFJ-1010W	針狀軸承	Needle Bearing	1	ZMA04001	螺絲	Screw (M4-0.7x3)	2
J1060-0A	天秤組	Thread Take-up Assy.	1	ZMA05002	螺絲	Screw (M5-0.8x4.5)	4
J1061-0A	天秤固定銷	Take-up Lever Support Stud	1	ZMA06003	螺絲	Screw (M6-0.75x7)	1
J1064-0A	天秤架	Take-up Frame	1	ZMA07001	螺絲	Screw (M7-1.0x16.5)	1
J1065-0A	天秤桿	Take-up Lever	1	ZMB07001	螺絲	Screw (M7-1.0x21)	1
J1065-1A	線道	Bushing	1	ZMC06002	螺絲	Screw (M6-1.0x35)	1
J1066-0A	天秤曲柄	Take-up Crank Pin	1	ZMD04002	螺絲	Screw (M4-0.7x13.5)	1
J1067-0A	針棒連接器	Needle Bar Connecting Crank Rod	1	ZMD05001	螺絲	Screw (M5-0.8x10)	1
J1068-0A	定環	Collar	2	ZMH05003	螺絲	Screw (M5-0.8x8)	3
J1069-0A	天秤軸套管	Bushing	1	ZMH06002	螺絲	Screw (M6-1.0x7.5)	8
J1074-0A	針棒固定器	Needle Bar Connecting Stud	1	ZMH06004	螺絲	Screw (M6-0.75x10)	4
J1097-0A	墊片	Washer	1	ZMH06006	螺絲	Screw (M6-1.0x6)	2
J1099-0A	上軸套環	Bushing	1	ZMH06008	螺絲	Screw (M6-1.0x6)	2
J1103-0B	上軸套環	Upper Shaft Bushing	1	ZMJ05002	螺絲	Screw (M5-0.8x12)	2
J1105-0A	皮帶輪	Balance Wheel	1	ZMJ05005	螺絲	Screw (M5-0.8x22)	4
J1106-0A	凸輪	Crank Cam	1				
J1242-0B	縫目指示環	Feed Regulator Scale	1				
J1242-1B	縫目指示環	Feed Regulator Scale	1				
J3030-0A	保護蓋	Plug	2				
J4321-0B	軸承套管(左)	Collar (Left)	1				

# E.CS-8810D/8820D 針棒機構 NEEDLE BAR MECHANISM

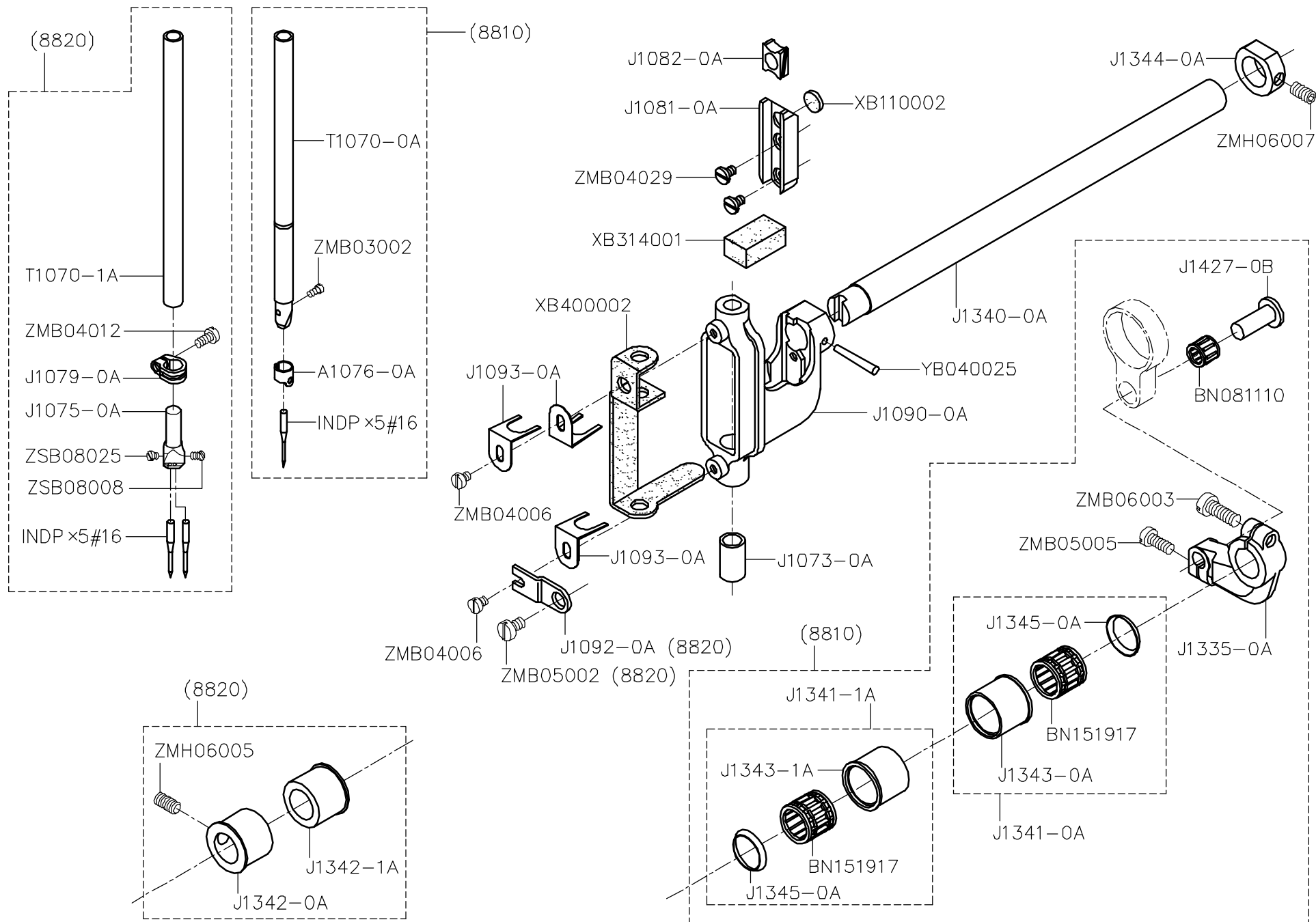

## E、CS-8810D、8820D 針棒機構 NEEDLE BAR MECHANISM

零件號碼 Part No	零件名稱	Name of Part	件數 Q, TY	零件號碼 Part No	零件名稱	Name of Part	件數 Q, TY
A1076-0A	針棒線掛	Thread Guide	1	XB110002	油棉	Oil Felt	1
BN081110	針狀軸承	Needle Bearing	1	XB314001	油棉	Oil Felt	1
BN151917	針狀軸承	Needle Bearing	2	XB400002	油棉	Oil Felt	1
INDPx5#16	針	Needle	2	YB040025	推拔銷	Taper Pin	1
J1073-0A	針棒套管	Needle Bar Bushing	1	ZMB03002	螺絲	Screw (M3-0.5x4)	1
J1075-0A	針鑰	Needle Holder	1	ZMB04006	螺絲	Screw (M4-0.7x4.5)	2
J1079-0A	針棒套夾	Ring Clamp	1	ZMB04012	螺絲	Screw (M4-0.7x8)	1
J1081-0A	針棒連接器導槽	Needle Bar Connecting Link Guide	1	ZMB04029	螺絲	Screw (M4-0.7x6)	2
J1082-0A	針棒導引滑塊	Needle Bar Guide Slide Block	1	ZMB05002	螺絲	Screw (M5-0.8x6)	1
J1090-0A	針棒座	Needle Bar Support Frame	1	ZMB05005	螺絲	Screw (M5-0.8x13)	1
J1092-0A	針棒座固定板	Needle Bar Support Frame Retainer	1	ZMB06003	螺絲	Screw (M6-1.0x16)	1
J1093-0A	油棉壓板	Holder	3	ZMH06005	螺絲	Screw (M6-1.0x12)	1
J1335-0A	針送支臂	Crank	1	ZMH06007	螺絲	Screw (M6-0.75x5)	1
J1340-0A	針送主軸	Needle Bar Shaft	1	ZSB08008	螺絲	Screw (1/8-44x4)	1
J1341-0A	軸套管	Bushing	1	ZSB08025	螺絲	Screw (1/8-44x3)	1
J1341-1A	軸套管	Bushing	1				
J1342-0A	套管	Bushing	1				
J1342-1A	套管	Bushing	1				
J1343-0A	套管	Bushing	1				
J1343-1A	套管	Bushing	1				
J1344-0A	定環	Collar	1				
J1345-0A	盤形墊圈	Washer	2				
J1427-0B	固定銷(短)	Pin	1				
T1070-0A	針棒	Needle Bar	1				
T1070-1A	針棒	Needle Bar	1				

# F.CS-8810D/8820D 押棒機構 PRESSER FOOT BAR MECHANISM

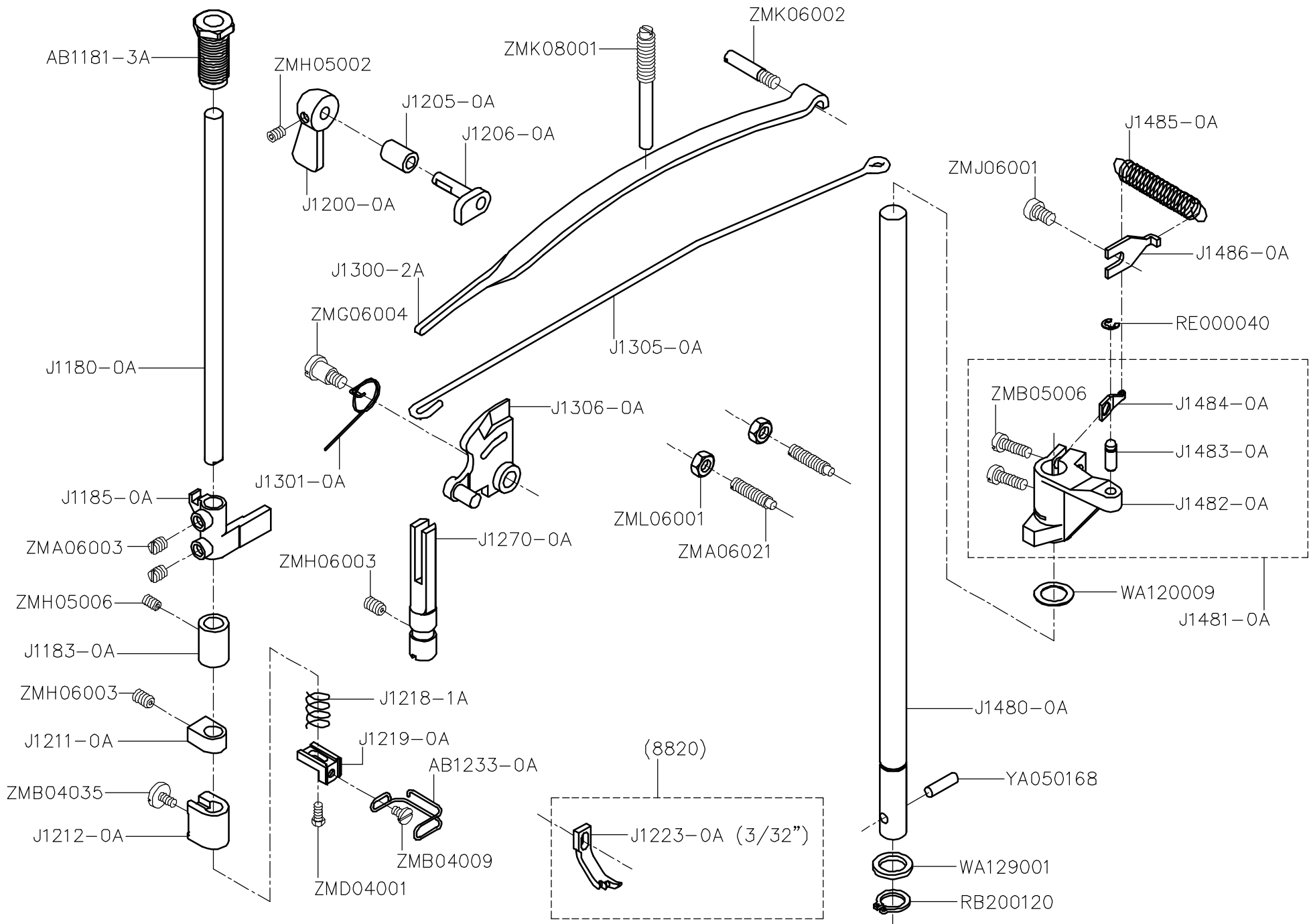

F、CS-8810D、8820D 押棒機構 PRESSER FOOT BAR MECHANISM

零件號碼 Part No	零件名稱	Name of Part	件數 Q, TY	零件號碼 Part No	零件名稱	Name of Part	件數 Q, TY
AB1181-3A	押腳上套管	Bushing	1	RB200120	C形扣環	C-ring	1
AB1233-0A	護手蓋	Cover	1	RE000040	E形扣環	E-ring	1
J1180-0A	押棒	Presser Bar	1	WA120009	墊圈	Washer	1
J1183-0A	押棒套管(下)	Presser Bar Bushing (Lower)	1	WA129001	墊圈	Washer	1
J1185-0A	押棒固定座	Presser Bar Holder	1	YA050168	平行銷	Pin	1
J1200-0A	押棒提桿	Presser Foot Lifter	1	ZMA06003	螺絲	Screw (M6-0.75x7)	2
J1205-0A	押棒提桿套管	Bushing	1	ZMA06021	螺絲	Screw (M6-1.0x28)	2
J1206-0A	押棒提桿軸	Cam Shaft	1	ZMB04009	螺絲	Screw (M4-0.7x6)	1
J1211-0A	輪錢上座	Roller Presser Holder	1	ZMB04035	螺絲	Screw (M4-0.7x8)	1
J1212-0A	輪錢下座	Roller Presser Holder	1	ZMB05006	螺絲	Screw (M5-0.8x16)	2
J1218-1A	彈簧	Spring	1	ZMD04001	螺絲	Screw (M4-0.7x8.5)	1
J1219-0A	頂針座	Angle	1	ZMG06004	螺絲	Hinge Screw	1
J1223-0A	壓腳(3/32")	Presser Foot	1	ZMH05002	螺絲	Screw (M5-0.8x6)	1
J1270-0A	軌導棒	Stud	1	ZMH05006	螺絲	Screw (M5-0.8x4)	1
J1300-2A	彈片壓板	Presser Plate Spring	1	ZMH06003	螺絲	Screw (M6-1.0x8)	2
J1301-0A	彈簧	Spring	1	ZMJ06001	螺絲	Screw (M6-1.0x8)	1
J1305-0A	腳弓連接槓桿	Knee Lifter Connecting Lever	1	ZMK06002	螺絲	Screw (M6-1.0)	1
J1306-0A	沙拉心座組	Lifting Lever Assy.	1	ZMK08001	螺絲	Screw (M8-0.75)	1
J1480-0A	腳壓動軸	Shaft	1	ZML06001	螺帽	Nut	2
J1481-0A	腳弓調整鈕頭組	Crank Assy.	1				
J1482-0A	上下輸送臂	Crank	1				
J1483-0A	彈簧固定銷	Pin	1				
J1484-0A	彈簧固板	Bracket	1				
J1485-0A	拉伸彈簧	Spring	1				
J1486-0A	彈簧固定板	Spring Plate	1				

# G.CS-8810D/8820D 擺動軸機構 ROCKING SHAFT MECHANISM

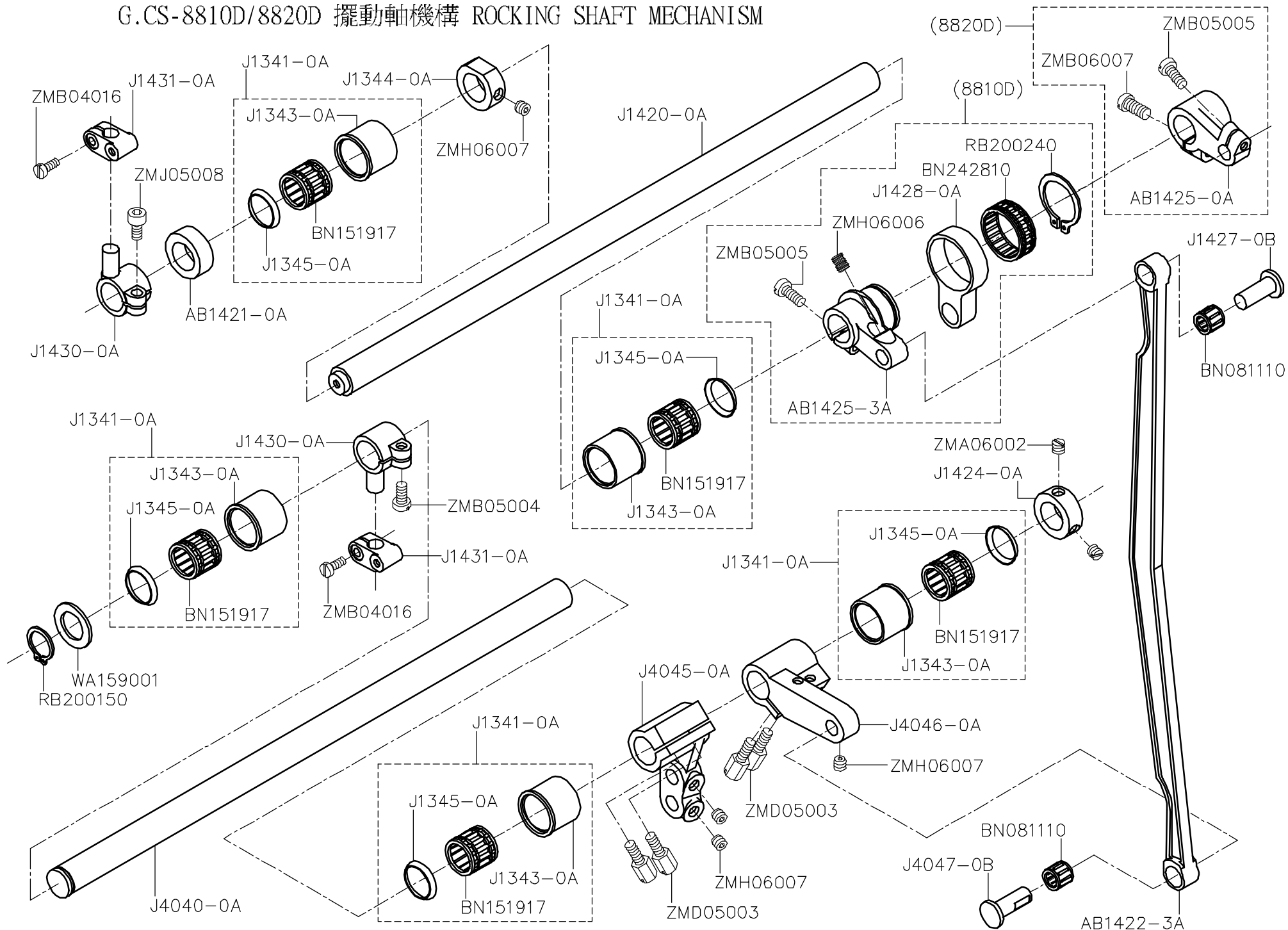

G、CS-8810D、8820D 擺動軸機構 ROCKING SHAFT MECHANISM

零件號碼 Part No	零件名稱	Name of Part	件數 Q, TY	零件號碼 Part No	零件名稱	Name of Part	件數 Q, TY
AB1421-0A	墊圈	Washer	1	RB200150	C形扣環	C-ring	1
AB1422-3A	連桿	Rod	1	RB200240	C形扣環	C-ring	1
AB1425-0A	上邊心支管	Supporting Arm	1	WA159001	墊圈	Washer	1
AB1425-3A	偏心輪	Eccentric	1	ZMA06002	螺絲	Screw (M6-0.75x4.5)	2
BN081110	針狀軸承	Needle Bearing	2	ZMB04016	螺絲	Screw (M4-0.7x10)	2
BN151917	針狀軸承	Needle Bearing	5	ZMB05004	螺絲	Screw (M5-0.8x10)	1
BN242810	針狀軸承	Needle Bearing	1	ZMB05005	螺絲	Screw (M5-0.8x13)	2
J1341-0A	軸套管	Bushing	5	ZMB06007	螺絲	Screw (M6-1.0x13)	1
J1343-0A	套管	Bushing	5	ZMD05003	螺絲	Screw (M5-0.8x12.5)	4
J1344-0A	定環	Collar	1	ZMH06006	螺絲	Screw (M6-0.75x6)	1
J1345-0A	盤型墊圈	Washer	5	ZMH06007	螺絲	Screw (M6-0.75x5)	4
J1420-0A	上邊心	Upper Side Shaft	1	ZMJ05008	螺絲	Screw (M5-0.8x10)	2
J1424-0A	上邊心定環	Collar	1				
J1427-0B	固定銷(短)	Pin	1				
J1428-0A	凸輪連桿	Eccentric Rod	1				
J1430-0A	萬向聯結頭	Crank	2				
J1431-0A	萬向聯結座	Clamp	2				
J4040-0A	輸送主軸	Shaft	1				
J4045-0A	單向輸送支臂	Crank	1				
J4046-0A	單向輸送支臂	Crank	1				
J4047-0B	固定銷(長)	Pin	1				



# H.CS-8810D/8820D 縫目調整器機構 STITCH REGULATOR MECHANISM

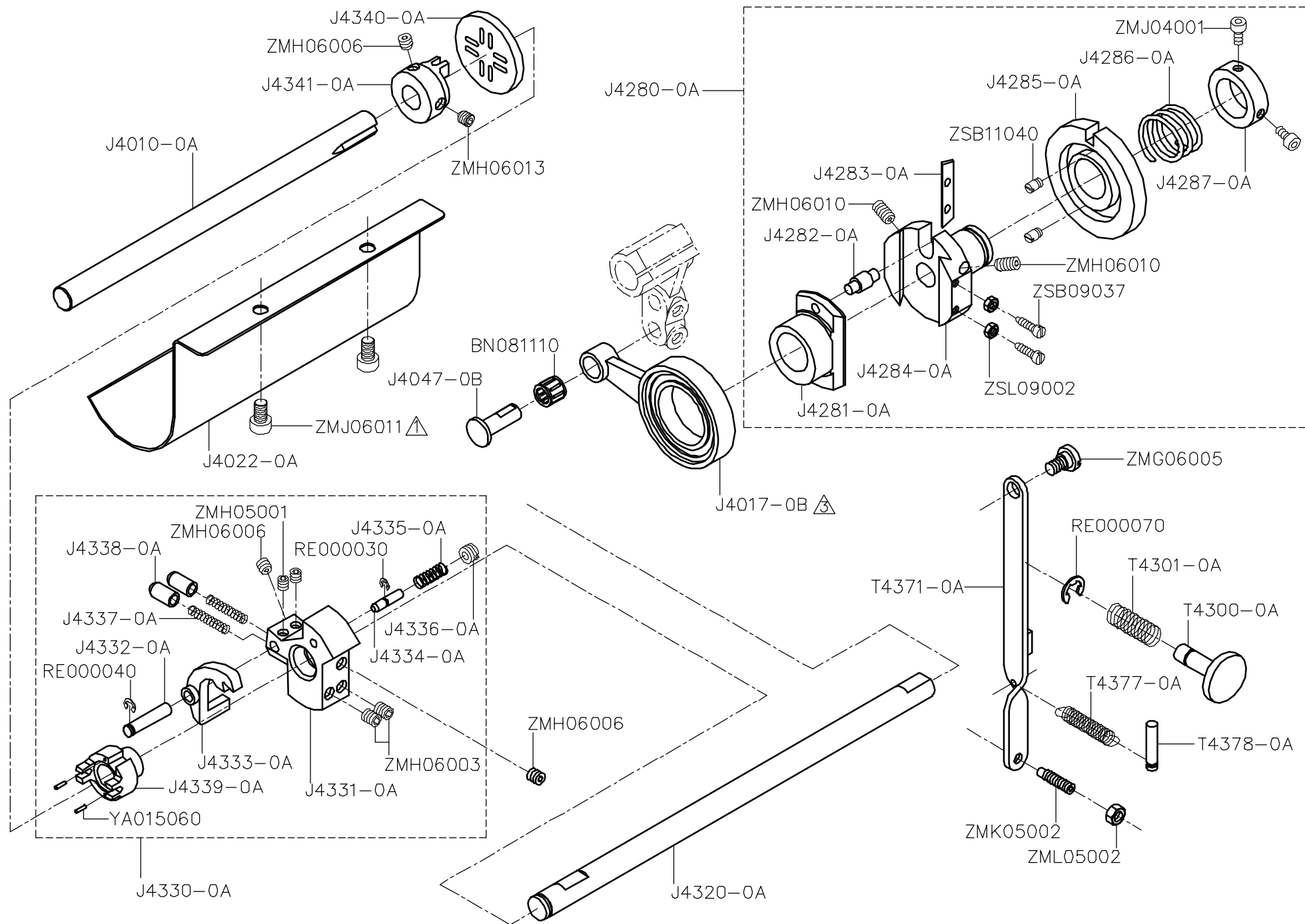

## H、CS-8810D、8820D 縫目調整器機構 STITCH REGULATOR MECHANISM

零件號碼 Part No	零件名稱 Name of Part	Name of Part	件數 Q, TY	零件號碼 Part No	零件名稱 Name of Part	Name of Part	件數 Q, TY
BN081110	針狀軸承	Needle Bearing	1	RE000030	E形扣環	E-ring	1
J4010-0A	萬向聯結軸(短)	Shaft	1	RE000040	E形扣環	E-ring	1
J4017-0B	連桿	Connecting Rod	1	RE000070	E形扣環	E-ring	1
J4022-0A	齒輪護蓋	Housing Front Section	1	T4300-0A	銷	Pin	1
J4047-0B	固定銷(長)	Bearing Stud	1	T4301-0A	彈簧	Spring	1
J4280-0A	凸輪組	Cam Assy.	1	T4371-0A	送料調節板	Feed Adjusting Plate	1
J4281-0A	縫目調整座	Stitch Regulating Seat	1	T4377-0A	彈簧	Spring	1
J4282-0A	偏心調整支軸	Feed Adjusting Screw	1	T4378-0A	彈簧固定銷	Pin	1
J4283-0A	迫緊片	Friction Plate	1	YA015060	平行銷	Pin	2
J4284-0A	縫目調整固定座	Stitch Regulating Fix Seat	1	ZMG06005	螺絲	Screw (M6-1.0x8)	1
J4285-0A	縫目調整偏心輪	Eccentric Wheel	1	ZMH05001	螺絲	Screw (M5-0.8x5)	2
J4286-0A	彈簧	Spring	1	ZMH06003	螺絲	Screw (M6-0.75x7.5)	2
J4287-0A	套環	Collar	1	ZMH06006	螺絲	Screw (M6-0.75x6)	3
J4320-0A	萬向聯結軸	Shaft	1	ZMH06010	螺絲	Screw (M6-0.75x10)	2
J4330-0A	離合器組	Safety Clutch	1	ZMH06013	螺絲	Screw (M6-0.75x8)	1
J4331-0A	離合器座	Safety Clutch Seat	1	ZMJ04001	螺絲	Screw (M4-0.7x8)	2
J4332-0A	固定座	Hinge Stud	1	ZMJ06011	螺絲	Screw (M6-1.0x10)	2
J4333-0A	離合器爪	Latch	1	ZMK05002	螺絲	Screw (M5-0.8)	1
J4334-0A	固定銷	Drop-In Pin	1	ZML05002	螺帽	Nut	1
J4335-0A	壓縮彈簧	Spring	1	ZSB09037	螺絲	Screw (9/64-40x12)	2
J4336-0A	固定螺絲	Ring	1	ZSB11040	螺絲	Screw (11/64-40x2.5)	2
J4337-0A	彈簧	Spring	2	ZSL09002	螺帽	Nut	2
J4338-0A	彈簧固定套	Stud	2				
J4339-0A	軸連器(右)	Coupler (Right)	1				
J4340-0A	連接板	Connecting Plate	1				
J4341-0A	軸連器(左)	Coupler (Left)	1				

# I.CS-8810D 送料機構 FEEDING MECHANISM

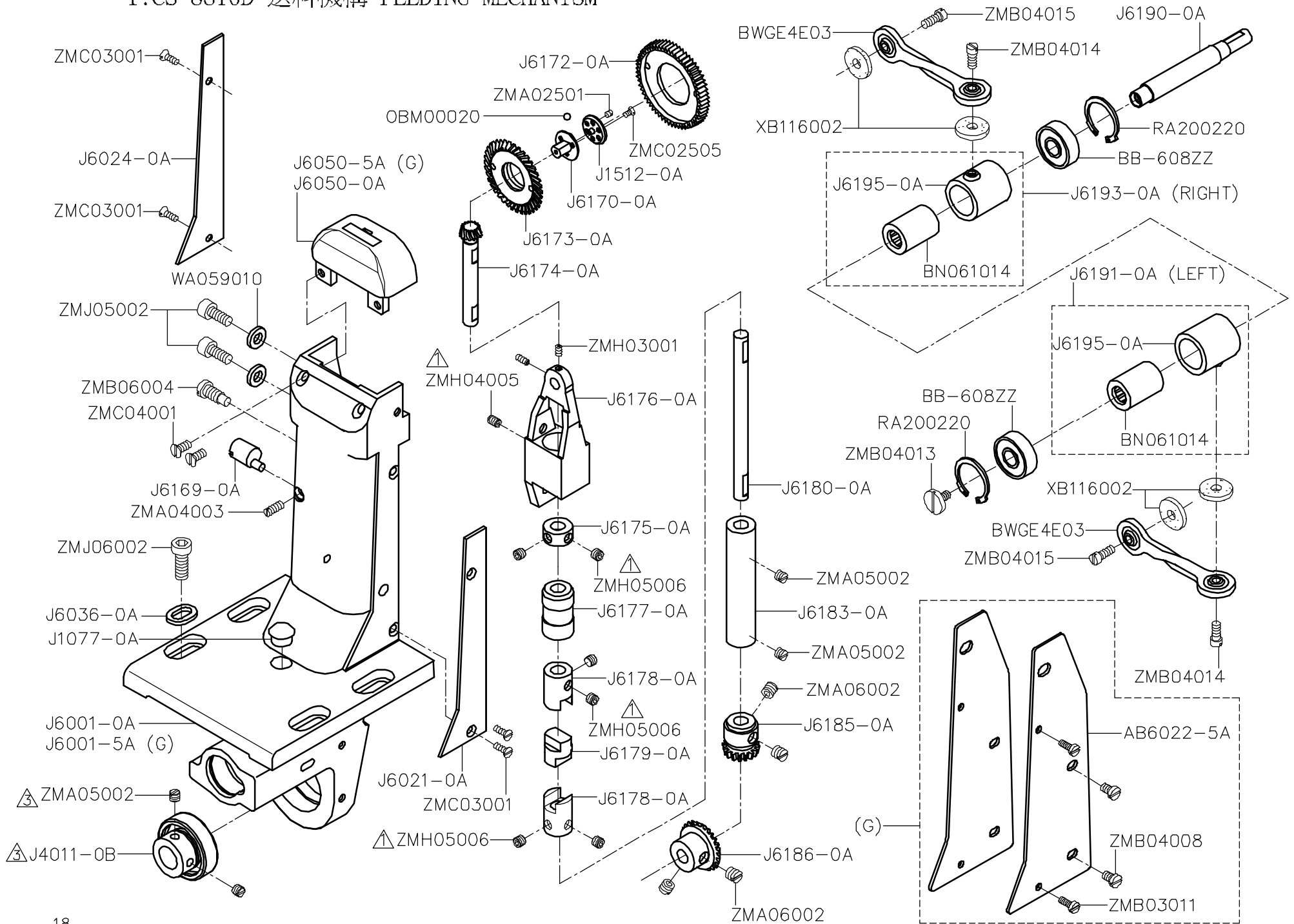

I、CS-8810D、8820D 送料機構 FEEDING MECHANISM

零件號碼 Part No	零件名稱	Name of Part	件數 Q, TY	零件號碼 Part No	零件名稱	Name of Part	件數 Q, TY
AB6022-5A	邊蓋板	Cover Plate	1	J6191-0A	單向培林座組(左)	Free-Wheeling (Left)	1
BB-608ZZ	滾珠軸承	Ball Bearing	2	J6193-0A	單向培林座組(右)	Free-Wheeling (Right)	1
BN061014	針狀軸承	Needle Bearing	2	J6195-0A	單向培林座	Free-Wheeling Seat	2
BWGE4E03	球狀萬向軸承拉桿	Link	2	OBM00020	鋼珠(2m/m)	Ball	6
J1077-0A	油蓋	Needle Bar Upper Bushing Cap	1	RA200220	C形扣環	C-ring	1
J1512-0A	輪錢軸座(前)	Presser Shaft Seat (Front)	1	WA059010	墊圈	Washer	2
J4011-0B	主軸套管	Collar	1	XB116002	油棉	Felt	4
J6001-0A	單針中座	Support Plate	1	ZMA02501	螺絲	Screw (M2.5-0.45x2)	1
J6001-5A	單針中座	Support Plate	1	ZMA04003	螺絲	Screw (M4-0.7x10)	1
J6021-0A	邊蓋板	Cover Plate	1	ZMA05002	螺絲	Screw (M5-0.8x4.5)	4
J6024-0A	邊蓋板	Cover Plate	1	ZMA06002	螺絲	Screw (M6-0.75x4.5)	4
J6036-0A	墊圈	Washer	4	ZMB03011	螺絲	Screw (M3-0.5x8)	2
J6050-0A	針板	Needle Plate	1	ZMB04008	螺絲	Screw (M4-0.7x6)	2
J6050-5A	針板	Needle Plate	1	ZMB04013	螺絲	Screw (M4-0.7x8)	1
J6169-0A	調整銷	Stud	1	ZMB04014	螺絲	Screw (M4-0.7x8)	2
J6170-0A	送料齒輪軸(上)	Roller Bracket (Upper)	1	ZMB04015	螺絲	Screw (M4-0.7x8.5)	2
J6172-0A	送料齒	Feed Wheel	1	ZMB06004	螺絲	Screw (M6-1.0x14)	1
J6173-0A	送料齒輪(上)	Bevel Gear (Upper)	1	ZMC02505	螺絲	Screw (M2.5-0.45x4.8)	1
J6174-0A	送料齒輪(下)	Bevel Gear (Lower)	1	ZMC03001	螺絲	Screw (M3-0.5x8.5)	4
J6175-0A	定環	Collar	1	ZMC04001	螺絲	Screw (M4-0.7x8.5)	2
J6176-0A	渦線齒輪座	Bracket	1	ZMH03001	螺絲	Screw (M3-0.5x4)	2
J6177-0A	送料齒輪套管	Bushing	1	ZMH04005	螺絲	Screw (M4-0.7x6)	1
J6178-0A	軸連接器	Bushing	2	ZMH05006	螺絲	Screw (M5-0.8x4)	6
J6179-0A	塑膠接頭	Clutch	1	ZMJ05002	螺絲	Screw (M5-0.8x12)	2
J6180-0A	中座軸	Shaft	1	ZMJ06002	螺絲	Screw (M6-1.0x15)	4
J6183-0A	套管	Bushing	1				
J6185-0A	中座齒輪(小)	Bevel Gear (Small)	1				
J6186-0A	中座齒輪(大)	Bevel Gear (Large)	1				
J6190-0A	軸	Shaft	1				

# J.CS-8820D 左邊邊座機構 LEFT SIDE POST MECHANISM (1)

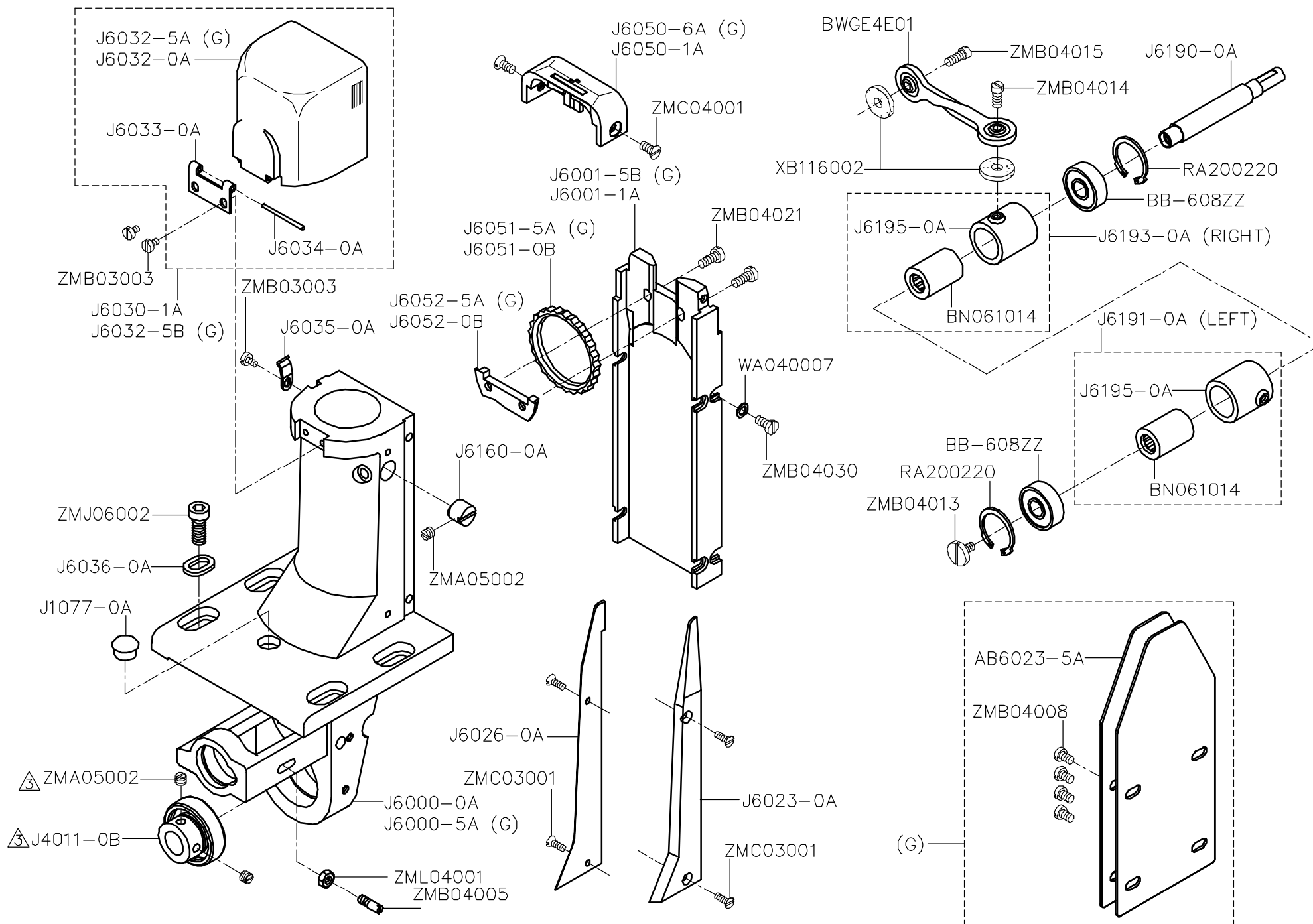

J、CS-8810D、8820D 左邊邊座機構(一) LEFT SIDE POST MECHANISM (1)

零件號碼 Part No	零件名稱	Name of Part	件數 Q, TY	零件號碼 Part No	零件名稱	Name of Part	件數 Q, TY
AB6023-5A	邊蓋板	Cover Plate	1	J6195-0A	單向培林座	Free-Wheeling Seat	2
BB-608ZZ	滾珠軸承	Ball Bearing	2	RA200220	C形扣環	C-ring	2
BN061014	針狀軸承	Needle Bearing	2	WA040007	墊圈	Washer	1
BWGE4E01	球狀萬向軸承拉桿	Link	1	XB116002	油棉	Felt	2
J1077-0A	油蓋	Needle Bar Upper Bushing Cap	1	ZMA05002	螺絲	Screw (M5-0.8x4.5)	3
J4011-0B	主軸套管	Collar	1	ZMB03003	螺絲	Screw (M3-0.5x4.7)	3
J6000-0A	附耳邊座(左)	Side Bracket (Left)	1	ZMB04005	螺絲	Screw (M4-0.7x6)	1
J6000-5A	附耳邊座(左)	Side Bracket (Left)	1	ZMB04008	螺絲	Screw (M4-0.7x8)	4
J6001-1A	雙針中座	Support Plate	1	ZMB04013	螺絲	Screw (M4-0.7x8)	1
J6001-5B	雙針中座	Support Plate	1	ZMB04014	螺絲	Screw (M4-0.7x8)	1
J6023-0A	邊蓋板	Cover Plate	1	ZMB04015	螺絲	Screw (M4-0.7x8.5)	1
J6026-0A	邊蓋板	Cover Plate	1	ZMB04021	螺絲	Screw (M4-0.7x10)	2
J6030-1A	釜蓋	Post Cap Assy.	1	ZMB04030	螺絲	Screw (M4-0.7x8)	1
J6032-0A	護蓋	Post Cap	1	ZMC03001	螺絲	Screw (M3-0.5x8.5)	4
J6032-5A	護蓋	Post Cap	1	ZMC04001	螺絲	Screw (M4-0.7x8.5)	2
J6032-5B	釜蓋	Post Cap Assy.	1	ZMJ06002	螺絲	Screw (M6-1.0x15)	4
J6033-0A	活動板	Hinge	1	ZML04001	螺帽	Nut	1
J6034-0A	固定銷	Pin	1				
J6035-0A	彈簧板	Spring	1				
J6036-0A	平墊圈	Washer	4				
J6050-1A	雙針針板	Needle Plate	1				
J6050-6A	雙針針板	Needle Plate	1				
J6051-0B	送料輪	Feed Wheel	1				
J6051-5A	送料輪	Feed Wheel	1				
J6052-0B	送料輪固定板	Bearing Plate	1				
J6052-5A	送料輪固定板	Bearing Plate	1				
J6160-0A	調整銷	Eccentric Stud	1				
J6190-0A	軸	Shaft	1				
J6191-0A	單向培林座組(左)	Free-Wheeling (Left)	1				
J6193-0A	單向培林座組(右)	Free-Wheeling (Right)	1				

# K.CSA-8820D 左邊邊座機構 LEFT SIDE POST MECHANISM (2)

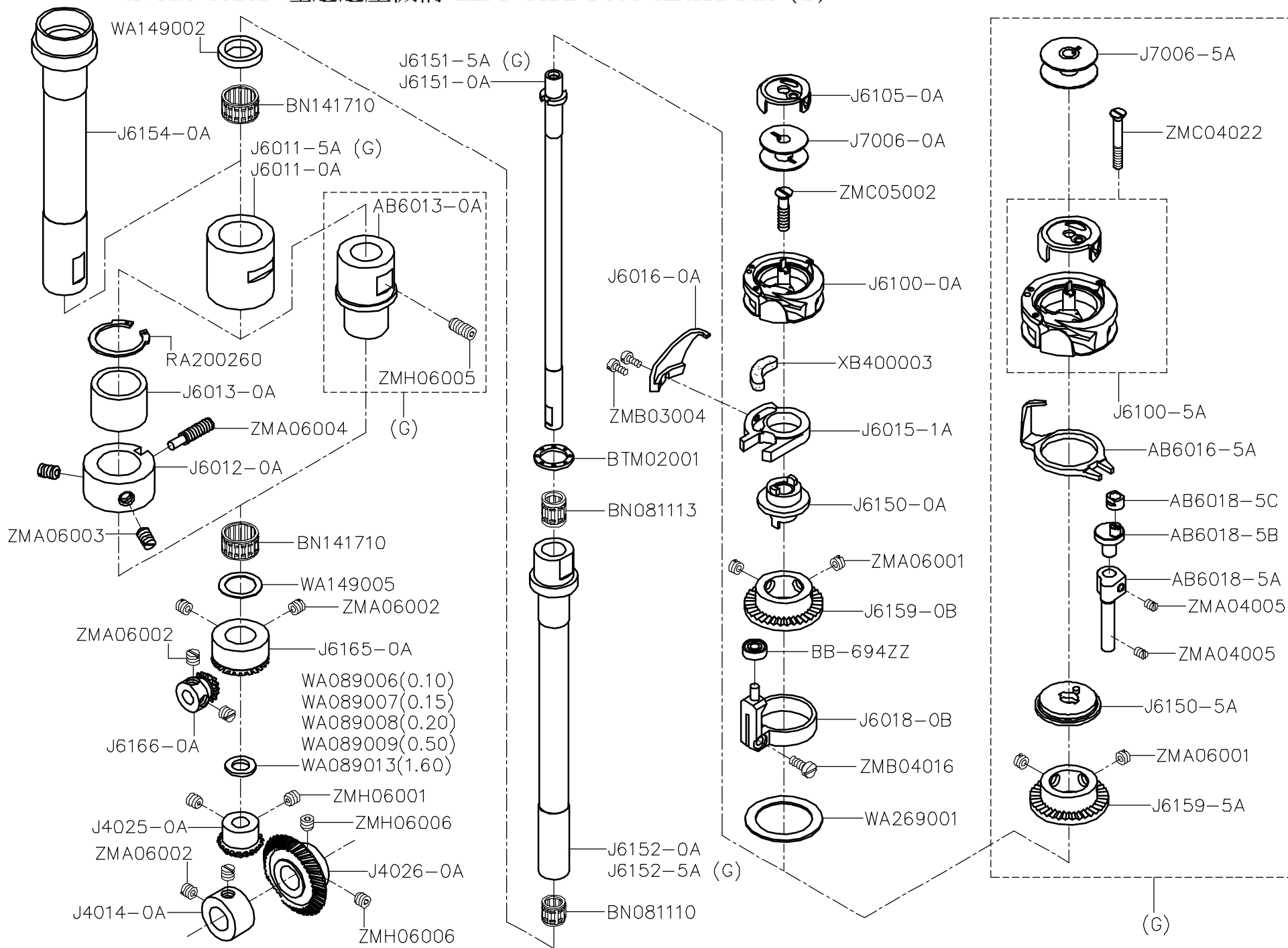

K、CS-8810D、8820D 左邊邊座機構(二) LEFT SIDE POST MECHANISM (2)

零件號碼 Part No	零件名稱	Name of Part	件數 Q, TY	零件號碼 Part No	零件名稱	Name of Part	件數 Q, TY
AB6013-0A	釜軸套管	Bushing	1	J6159-5A	銅齒	Driving Wheel	1
AB6016-5A	牛角	Rotating Hook Opener	1	J6165-0A	齒輪(大)	Bevel Gear (Large)	1
AB6018-5A	牛角座	Rotating Hook Opener Bracket	1	J6166-0A	齒輪(小)	Bevel Gear (Small)	1
AB6018-5B	牛角軸	Rotating Hook Opener Shaft	1	J7006-0A	梭仔	Bobbin	1
AB6018-5C	牛角滑塊	Rotating Hook Opener Slide Block	1	J7006-5A	梭仔	Bobbin	1
BB-694ZZ	滾珠軸承	Ball Bearing	1	RA200260	C形扣環	C-ring	1
BN081110	針狀軸承	Needle Bearing	1	WA089006	墊圈(0.10)	Washer	1
BN081113	針狀軸承	Needle Bearing	1	WA089007	墊圈(0.15)	Washer	1
BN141710	針狀軸承	Needle Bearing	2	WA089008	墊圈(0.20)	Washer	1
BTM02001	止推軸承	Thrust Bearing	1	WA089009	墊圈(0.50)	Washer	1
J4014-0A	定環	Collar	1	WA089013	墊圈(1.60)	Washer	1
J4025-0A	齒輪(小)	Bevel Gear (Small)	1	WA149002	墊圈	Washer	1
J4026-0A	齒輪(大)	Bevel Gear (Large)	1	WA149005	墊圈	Washer	1
J6011-0A	釜軸套管	Bushing	1	WA269001	墊圈	Washer	1
J6011-5A	釜軸套管	Bushing	1	XB400003	油棉	Felt	1
J6012-0A	釜軸套管	Bushing	1	ZMA04005	螺絲	Screw (M4-0.7x4)	2
J6013-0A	釜軸套管	Bushing	1	ZMA06001	螺絲	Screw (M6-0.75x3.5)	4
J6015-1A	牛角座	Rotating Hook Opener Bracket	1	ZMA06002	螺絲	Screw (M6-0.75x4.5)	6
J6016-0A	牛角	Rotating Hook Opener	1	ZMA06003	螺絲	Screw (M6-0.75x7)	2
J6018-0B	牛角固定座	Driver (For Bearing)	1	ZMA06004	螺絲	Screw (M6-1.0x25)	1
J6100-0A	梭頭	Hook	1	ZMB03004	螺絲	Screw (M3-0.5x5.7)	2
J6100-5A	梭頭	Hook	1	ZMB04016	螺絲	Screw (M4-0.7x10)	1
J6105-0A	梭殼	Bobbin Case	1	ZMC04022	螺絲	Screw (M4-0.7x29)	1
J6150-0A	梭軸頭	Hook Driver	1	ZMC05002	螺絲	Screw (M5-0.8x20)	1
J6150-5A	梭軸頭	Hook Driver	1	ZMH06001	螺絲	Screw (M6-0.75x4)	2
J6151-0A	釜軸	Hook Shaft	1	ZMH06005	螺絲	Screw (M6-1.0x12)	1
J6151-5A	釜軸	Hook Shaft	1	ZMH06006	螺絲	Screw (M6-0.75x6)	2
J6152-0A	釜軸中套管	Feed Wheel Shaft	1				
J6152-5A	釜軸中套管	Feed Wheel Shaft	1				
J6154-0A	釜軸外套管	Pull-Off Shaft	1				
J6159-0B	面齒輪	Face Gear	1				



# L.CS-8810D/8820D 右邊邊座機構 RIGHT SIDE POST MECHANISM (1)

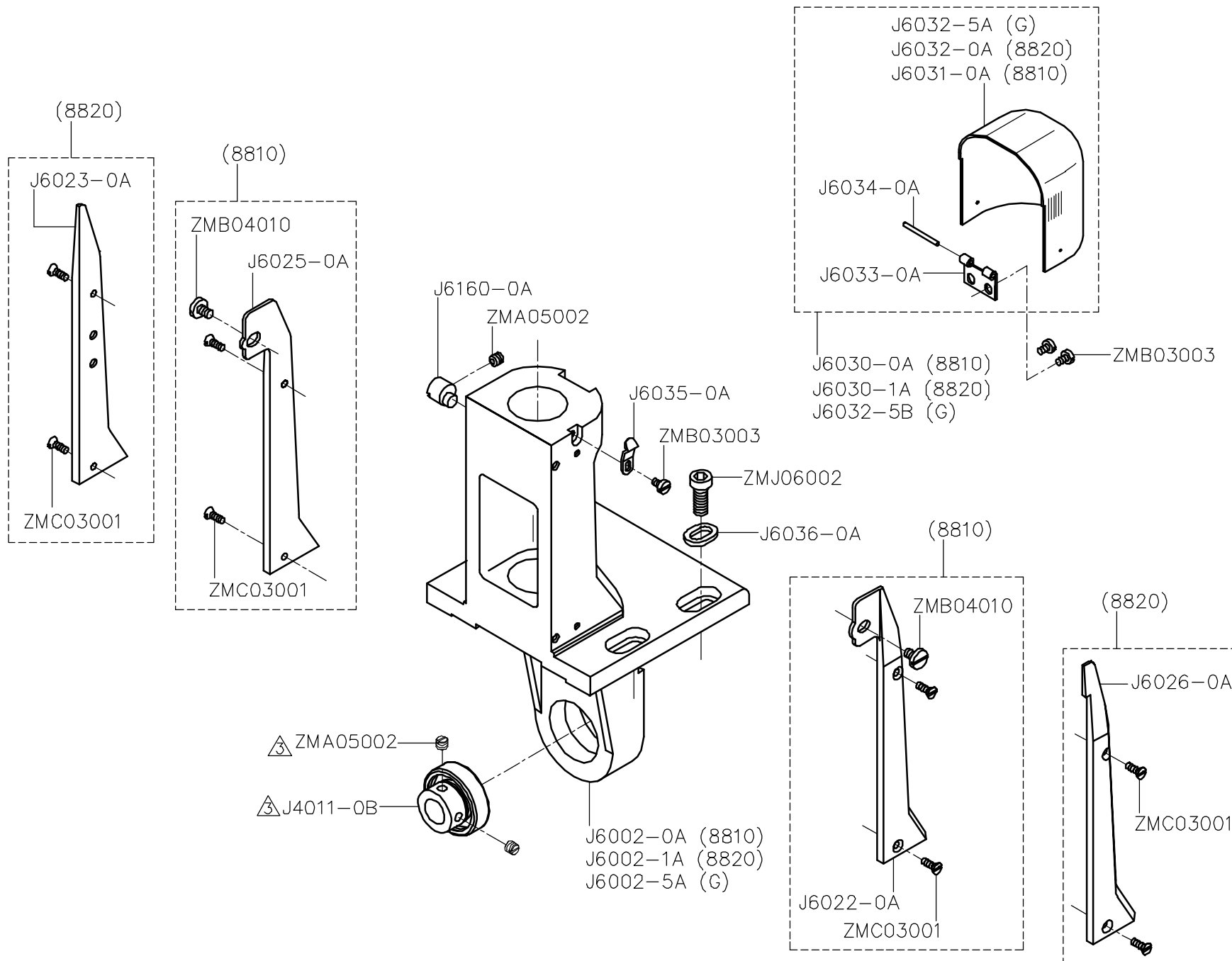

L、CS-8810D、8820D 右邊邊座機構(一) RIGHT SIDE POST MECHANISM (1)

零件號碼 Part No	零件名稱	Name of Part	件數 Q, TY	零件號碼 Part No	零件名稱	Name of Part	件數 Q, TY
BB6002ZZ	滾珠軸承	Ball Bearing	1				
J4011-0B	主軸套管	Bushing	1				
J6002-0A	單針邊座	Side Bracket	1				
J6002-1A	雙針邊座	Side Bracket	1				
J6002-5A	雙針邊座	Side Bracket	1				
J6022-0A	邊蓋板	Cover Plate	1				
J6023-0A	邊蓋板	Cover Plate	1				
J6025-0A	邊蓋板	Cover Plate	1				
J6026-0A	邊蓋板	Cover Plate	1				
J6030-0A	釜蓋	Post Cap Assy.	1				
J6030-1A	釜蓋	Post Cap Assy.	1				
J6031-0A	護蓋	Post Cap	1				
J6032-0A	護蓋	Post Cap	1				
J6032-5A	護蓋	Post Cap	1				
J6032-5B	護蓋	Post Cap	1				
J6033-0A	活動板	Hinge	1				
J6034-0A	固定銷	Pin	1				
J6035-0A	彈簧板	Spring	1				
J6036-0A	墊圈	Washer	4				
J6160-0A	調整銷	Eccentric Stud	1				
ZMA05002	螺絲	Screw (M5-0.8x4.5)	3				
ZMB03003	螺絲	Screw (M3-0.5x4.7)	3				
ZMB04010	螺絲	Screw (M4-0.7x6)	2				
ZMC03001	螺絲	Screw (M3-0.5x8.5)	4				
ZMJ06002	螺絲	Screw (M6-1.0x15)	4				

M.CS-8810D/8820D 右邊邊座機構 RIGHT SIDE POST MECHANISM (2)

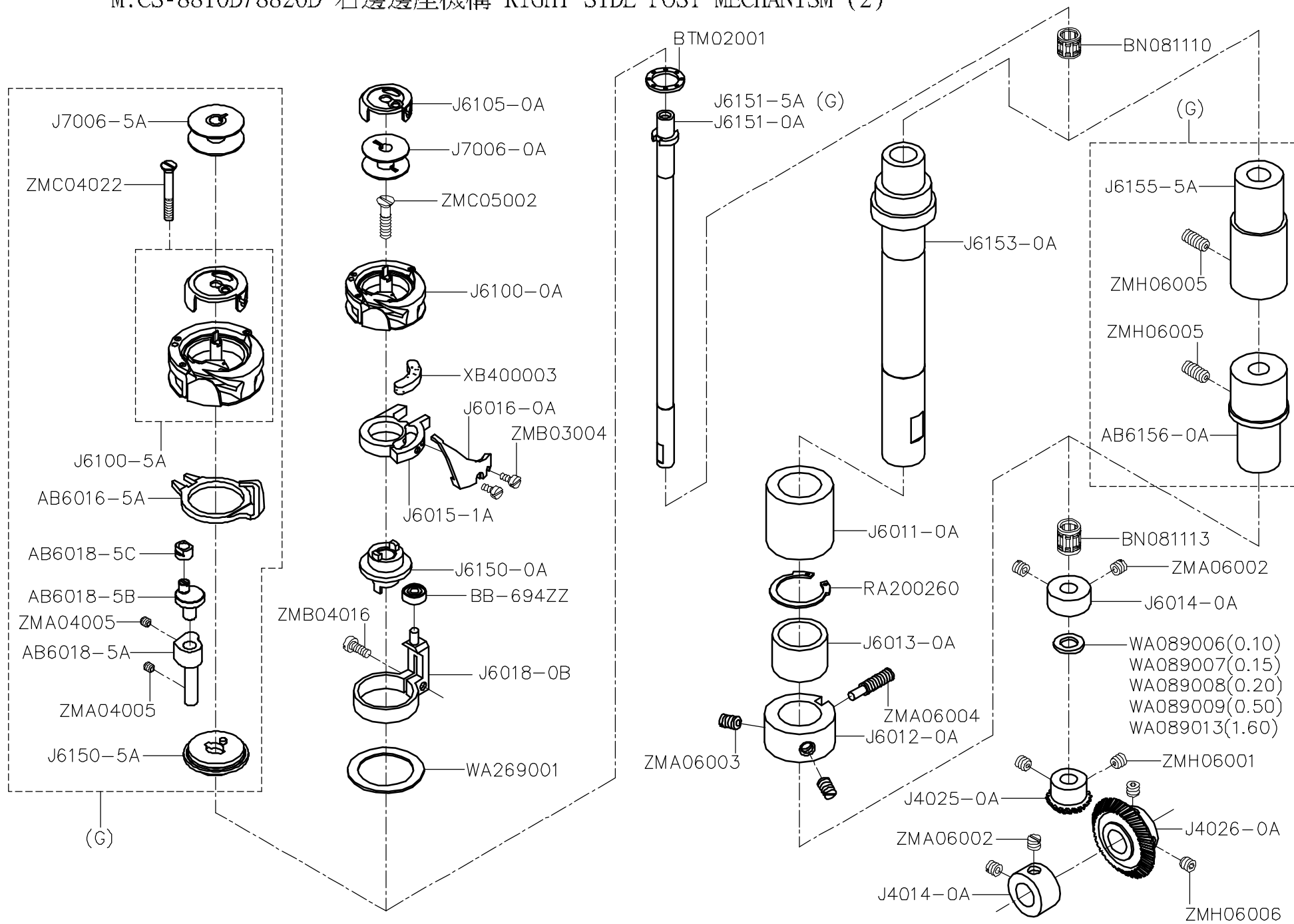

M、CS-8810D、8820D 右邊邊座機構(二) RIGHT SIDE POST MECHANISM (2)

零件號碼 Part No	零件名稱	Name of Part	件數 Q, TY	零件號碼 Part No	零件名稱	Name of Part	件數 Q, TY
AB6016-5A	牛角	Rotating Hook Opener	1	RA200260	C形扣環	C-ring	1
AB6018-5A	牛角座	Rotating Hook Opener Bracket	1	WA089006	墊圈(0.10)	Washer	1
AB6018-5B	牛角軸	Rotating Hook Opener Shaft	1	WA089007	墊圈(0.15)	Washer	1
AB6018-5C	牛角滑塊	Rotating Hook Opener Slide Block	1	WA089008	墊圈(0.20)	Washer	1
AB6156-0A	套管	Bushing	1	WA089009	墊圈(0.50)	Washer	1
BB-694ZZ	滾珠軸承	Ball Bearing	1	WA089013	墊圈(1.60)	Washer	1
BN081110	針狀軸承	Needle Bearing	1	WA269001	墊圈	Washer	1
BN081113	針狀軸承	Needle Bearing	1	XB400003	油棉	Felt	1
BTM02001	止推軸承	Thrust Bearing	1	ZMA04005	螺絲	Screw (M4-0.7x4)	2
J4014-0A	定環	Collar	1	ZMA06002	螺絲	Screw (M6-0.75x4.5)	4
J4025-0A	齒輪(小)	Bevel Gear (Small)	1	ZMA06003	螺絲	Screw (M6-0.75x7)	2
J4026-0A	齒輪(大)	Bevel Gear (Large)	1	ZMA06004	螺絲	Screw (M6-0.75x25)	1
J6011-0A	釜軸套管	Bushing	1	ZMB03004	螺絲	Screw (M3-0.5x5.7)	2
J6012-0A	釜軸套管	Bushing	1	ZMB04016	螺絲	Screw (M4-0.7x10)	1
J6013-0A	釜軸套管	Bushing	1	ZMC04022	螺絲	Screw (M4-0.7x29)	1
J6014-0A	定環	Collar	1	ZMC05002	螺絲	Screw (M5-0.8x20)	1
J6015-1A	牛角座	Rotating Hook Opener Bracket	1	ZMH06001	螺絲	Screw (M6-0.75x4)	2
J6016-0A	牛角	Rotating Hook Opener	1	ZMH06005	螺絲	Screw (M6-1.0x12)	3
J6018-0B	牛角固定座	Driver (For Bearing)	1	ZMH06006	螺絲	Screw (M6-0.75x6)	2
J6100-0A	梭頭	Hook	1				
J6100-5A	梭頭	Hook	1				
J6105-0A	梭殼	Bobbin Case	1				
J6150-0A	梭軸頭	Hook Driver	1				
J6150-5A	梭軸頭	Hook Driver	1				
J6151-0A	釜軸	Hook Shaft	1				
J6151-5A	釜軸	Hook Shaft	1				
J6153-0A	釜軸中套管	Feed Wheel Shaft	1				
J6155-5A	釜軸套管	Bushing	1				
J7006-0A	梭仔	Bobbin	1				
J7006-5A	梭仔	Bobbin	1				

# N.CS-8810D/8820D 附件 ACCESSORIES

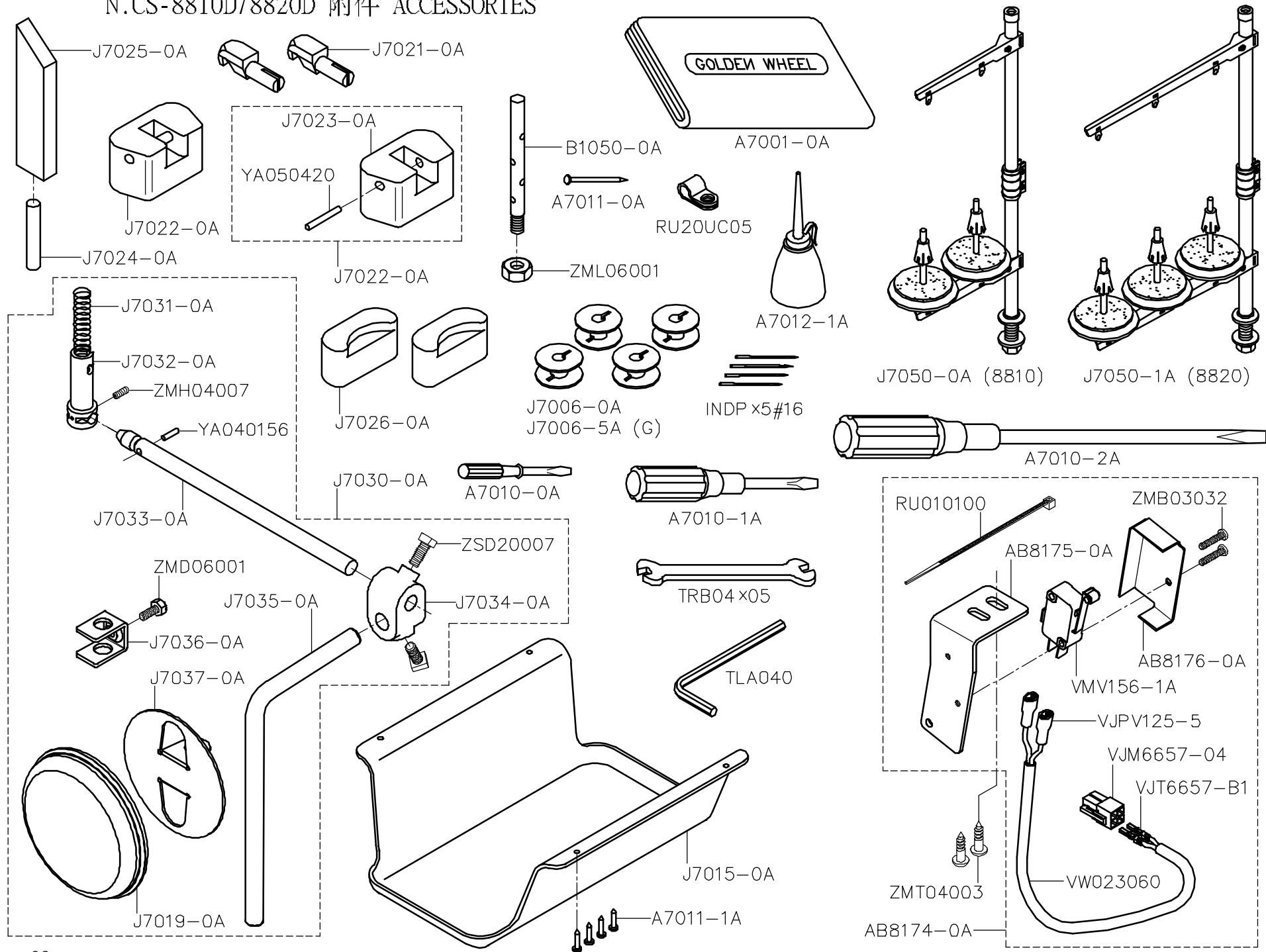

N、CS-8810D、8820D 附件 ACCESSORIES

零件號碼 Part No	零件名稱	Name of Part	件數 Q, TY	零件號碼 Part No	零件名稱	Name of Part	件數 Q, TY
A7001-0A	車頭蓋	Vinyl Cover	1	J7050-0A	2P 線架	Thread Stand (2-Pole)	1
A7010-0A	螺絲起子(小)	Screw Driver (Small)	1	J7050-1A	3P 線架	Thread Stand (3-Pole)	1
A7010-1A	螺絲起子(中)	Screw Driver (Middle)	1	RU010100	紮線帶	Cable Tie	1
A7010-2A	螺絲起子(大)	Screw Driver (Large)	1	RU20UC05	配線固定鈕	Cable Clamp	1
A7011-0A	鐵釘	Nail	1	TLA040	六角扳手(3mm)	Hexagonal Wrench(3mm)	1
A7011-1A	鐵釘	Nail	1	TRB04x05	開口扳手	Spanner 4x5	1
A7012-1A	油壺(中)	Oilier (Middle)	1	VJM6657-04	空中接頭	Housing 12P	1
AB8174-0A	安全開關組	Switch Assy.	1	VJPV125-5	絕緣端子	Insulate Terminals	2
AB8175-0A	安全開關固定板	Switch Plate	1	VJT6657-B1	母端子	Crimp Terminals	2
AB8176-0A	安全開關護蓋	Switch Cover	1	VMV156-1A	微動開關	Switch	1
B1050-0A	線柱	Spool Pin	1	VW023060	電源線	Electric	1
INDPx5#16	針	Needle	4	YA040156	平行銷	Pin	1
J7006-0A	梭仔	Bobbin	1	YA050420	平行銷	Pin	2
J7006-5A	梭仔	Bobbin	1	ZMB03032	螺絲	Screw (M3-0.5x15)	2
J7015-0A	下油槽	Oil Pan	1	ZMD06001	螺絲	Screw (M6-1.0x7)	1
J7019-0A	海棉墊	Knee Guard	1	ZMH04007	螺絲	Screw (M4-0.7x10)	1
J7021-0A	後鈕鉤	Hinge Pin	2	ZML06001	螺帽	Nut	1
J7022-0A	後鈕座組	Hinge Connection Seat Assy.	2	ZMT04003	螺絲	Screw	2
J7023-0A	後鈕座	Hinge Connection Seat	2	ZSD20007	螺絲	Screw (5/16-18x16)	2
J7024-0A	固定銷	Housing Support Stud	1				
J7025-0A	枕木	Head Rest Wood	1				
J7026-0A	橡膠墊	Head Cushion	2				
J7030-0A	腳弓組	Knee Lever Bottom Parts Assy.	1				
J7031-0A	彈簧	Spring	1				
J7032-0A	腳押連桿頭	Knee Lever Coupling	1				
J7033-0A	腳押直桿	Knee Lever Rod	1				
J7034-0A	連接器	Clamp	1				
J7035-0A	腳押曲桿	Knee Lever Rod	1				
J7036-0A	固定支架	Retainer	1				
J7037-0A	腳弓大餅	Knee Plate	1				

0.CS-8810D/8820D 針位圖號詳表 GAUGE PARTS LIST

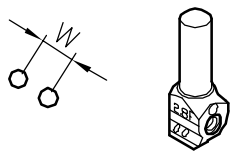
	
8820 針留 NEEDLE CLAMP	
W 規格 SPECIFICATION	零件號碼 PART NO.
1.7	J1075-200A
2.0	J1075-100A
2.4	J1075-050A
2.8	J1075-010A
3.0	J1075-040A
3.2	J1075-020A
4.0	J1075-080A
4.8	J1075-110A
5.5	J1075-030A

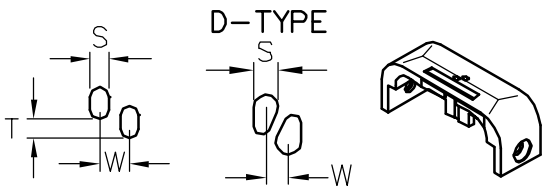
	
8820 針板 NEEDLE PLATE	
W x S x T 規格 SPECIFICATION	零件號碼 PART NO.
D - 1.6 x 2.4	J6050-1A
1.6 x 1.2 x 2.3	J6050-131A
2.0 x 1.2 x 2.0	J6050-121A
2.0 x 1.8 x 2.7	J6050-061A
2.4 x 1.8 x 0	J6050-141A
2.8 x 1.6 x 0	J6050-071A
3.0 x 2.1 x 0	J6050-051A
3.2 x 2.0 x 0	J6050-031A
4.0 x 1.6 x 0	J6050-081A
4.8 x 2.0 x 0	J6050-111A
5.5 x 2.0 x 0	J6050-041A
8820G 針板 NEEDLE PLATE	
D - 1.6 x 2.4	J6050-6A
D - 2.8 x 2.5	J6050-075D
2.0 x 1.5 x 1.9	J6050-5B
2.0 x 1.6 x 0	J6050-021G
2.4 x 1.8 x 0	J6050-141C

	
8810 針板 NEEDLE PLATE	
S x L 規格 SPECIFICATION	零件號碼 PART NO.
0.8 x 5.6	J6050-2A
1.2 x 3.4	J6050-040A
1.5 x 4.2	J6050-020A
2.0 x 2.0	J6050-030A
2.1 x 5.6	J6050-0A
8810G 針板 NEEDLE PLATE	
2.1 x 5.6	J6050-5A

2.8 x 1.6 x 0	J6050-071C
3.2 x 1.8 x 2.1	J6050-075C
3.2 x 2.0 x 0	J6050-031C
4.0 x 1.6 x 0	J6050-081C

P、CS-8810D、8820D 零件號碼與頁數對照 NUMERICAL PARTS-LIST

零件號碼 PARTS NO.	頁數 PAGE	零件號碼 PARTS NO.	頁數 PAGE	零件號碼 PARTS NO.	頁數 PAGE	零件號碼 PARTS NO.	頁數 PAGE	零件號碼 PARTS NO.	頁數 PAGE
A1076-0A	10	AB8175-0A	28	BB-688ZZ	6, 8	J1030-0A	4	J1090-0A	10
A7001-0A	28	AB8176-0A	28	BB-694ZZ	22, 26	J1031-0A	4	J1092-0A	10
A7010-0A	28	AC1020-4A	4	BN061014	6, 18, 20	J1032-0A	4	J1093-0A	10
A7010-1A	28	AC1021-4A	4	BN071008	8	J1033-0A	4	J1097-0A	8
A7010-2A	28	AC1034-4A	4	BN081110	10, 14, 16	J1034-0A	4	J1099-0A	8
A7011-0A	28	AC1035-4A	4	BN081110	22, 26	J1035-0A	4	J1103-0B	8
A7011-1A	28	AC1038-4A	4	BN081113	22, 26	J1036-0A	4	J1105-0A	8
A7012-1A	28	AC1081-0A	2	BN141710	22	J1037-0A	4	J1106-0A	8
AB1010-3A	2	AC1082-0A	2	BN151917	10, 14	J1038-0A	4	J1180-0A	12
AB1011-3A	2	AC1103-0A	8	BN242810	14	J1041-0A	4	J1183-0A	12
AB1014-3A	2	AC1524-0A	2	BNFJ-1010W	8	J1042-0A	4	J1185-0A	12
AB1055-0A	2	AC1525-0A	2	BTM02001	22, 26	J1043-0A	4	J1200-0A	12
AB1100-3A	8	AC1526-0A	2	BWGE4E01	6, 20	J1045-0A	4	J1205-0A	12
AB1181-3A	12	AC1527-0A	2	BWGE4E02	6	J1051-0A	2	J1206-0A	12
AB1233-0A	12	AC1528-0A	2	BWGE4E03	6, 18	J1060-0A	8	J1211-0A	12
AB1325-3A	8	AC1529-0A	2	BWGE4E04	6	J1061-0A	8	J1212-0A	12
AB1326-3A	8	AC1530-0B	2	BW-GE-8E	6	J1063-0A	2	J1213-0C	6
AB1327-4A	8	AC1531-0A	2	C1052-0A	2	J1064-0A	8	J1213-1C	6
AB1421-0A	14	AC1532-0A	2	INDPx5#16	10, 28	J1065-0A	8	J1213-3C	6
AB1422-3A	14	AC1533-0A	2	J1020-0A	4	J1065-1A	8	J1218-1A	12
AB1425-0A	14	AC1534-1B	2	J1020-1A	4	J1066-0A	8	J1219-0A	12
AB1425-3A	14	AC1534-2B	2	J1021-0A	4	J1067-0A	8	J1223-0A	12
AB3010-3A	8	AC1535-0A	2	J1024-0A	4	J1068-0A	8	J1242-0B	8
AB6013-0A	22	AC1536-0A	2	J1026-1A	4	J1069-0A	8	J1242-1B	8
AB6016-5A	22, 26	AC1537-0A	2	J1026-2A	4	J1073-0A	10	J1270-0A	12
AB6018-5A	22, 26	B1050-0A	28	J1026-3A	4	J1074-0A	8	J1300-2A	12
AB6018-5B	22, 26	BB6002ZZ	20, 24	J1027-0A	4	J1075-0A	10	J1301-0A	12
AB6018-5C	22, 26	BB-608ZZ	18, 20	J1027-1A	4	J1077-0A	2, 18, 20	J1305-0A	12
AB6022-5A	18, 20	BB6203ZZNR	8	J1028-0A	4	J1079-0A	10	J1306-0A	12
AB6156-0A	26	BB6204ZZNR	8	J1028-1A	4	J1081-0A	10	J1335-0A	10
AB8174-0A	28	BB-624ZZ	8	J1028-2A	4	J1082-0A	10	J1340-0A	10



P、CS-8810D、8820D 零件號碼與頁數對照 NUMERICAL PARTS-LIST

零件號碼 PARTS NO.	頁數 PAGE	零件號碼 PARTS NO.	頁數 PAGE	零件號碼 PARTS NO.	頁數 PAGE	零件號碼 PARTS NO.	頁數 PAGE	零件號碼 PARTS NO.	頁數 PAGE
J1341-0A	10, 14	J1513-0A	6	J4333-0A	16	J6024-0A	18	J6154-0A	22
J1341-1A	10	J1514-0A	6	J4334-0A	16	J6025-0A	24	J6155-5A	26
J1342-0A	10	J1514-1A	6	J4335-0A	16	J6026-0A	20, 24	J6159-0B	22
J1342-1A	10	J1515-0A	6	J4336-0A	16	J6030-0A	24	J6159-5A	22
J1343-0A	10, 14	J1515-1A	6	J4337-0A	16	J6030-1A	20, 24	J6160-0A	20, 24
J1343-1A	10	J3030-0A	8	J4338-0A	16	J6031-0A	24	J6165-0A	22
J1344-0A	10, 14	J4010-0A	16	J4339-0A	16	J6032-0A	20, 24	J6166-0A	22
J1345-0A	10, 14	J4011-0B	18, 20, 24	J4340-0A	16	J6032-5A	20, 24	J6169-0A	18
J1420-0A	14	J4014-0A	22, 26	J4341-0A	16	J6032-5B	20, 24	J6170-0A	18
J1424-0A	14	J4017-0B	16	J4360-0A	2	J6033-0A	20, 24	J6172-0A	18
J1427-0B	10, 14	J4022-0A	16	J6000-0A	20	J6034-0A	20, 24	J6173-0A	18
J1428-0A	14	J4025-0A	22, 26	J6000-5A	20	J6035-0A	20, 24	J6174-0A	18
J1430-0A	14	J4026-0A	22, 26	J6001-0A	18	J6036-0A	18, 20, 24	J6175-0A	18
J1431-0A	14	J4040-0A	14	J6001-1A	20	J6050-0A	18	J6176-0A	18
J1480-0A	12	J4045-0A	14	J6001-5A	18	J6050-1A	20	J6177-0A	18
J1481-0A	12	J4046-0A	14	J6001-5B	20	J6050-5A	18	J6178-0A	18
J1482-0A	12	J4047-0B	14, 16	J6002-0A	24	J6050-6A	20	J6179-0A	18
J1483-0A	12	J4280-0A	16	J6002-1A	24	J6051-0B	20	J6180-0A	18
J1484-0A	12	J4281-0A	16	J6002-5A	24	J6051-5A	20	J6183-0A	18
J1485-0A	12	J4282-0A	16	J6011-0A	22, 26	J6052-0B	20	J6185-0A	18
J1486-0A	12	J4283-0A	16	J6011-5A	22	J6052-5A	20	J6186-0A	18
J1500-0A	6	J4284-0A	16	J6012-0A	22	J6100-0A	22, 26	J6190-0A	18, 20
J1501-0A	6	J4285-0A	16	J6012-0A	26	J6100-5A	22, 26	J6191-0A	18, 20
J1505-0A	6	J4286-0A	16	J6013-0A	22, 26	J6105-0A	22, 26	J6193-0A	18, 20
J1510-0A	6	J4287-0A	16	J6014-0A	26	J6150-0A	22, 26	J6195-0A	18, 20
J1510-1A	6	J4320-0A	16	J6015-1A	22, 26	J6150-5A	22, 26	J7006-0A	22, 26, 28
J1510-3A	6	J4321-0B	8	J6016-0A	22, 26	J6151-0A	22, 26	J7006-5A	22, 26, 28
J1511-0C	6	J4323-0B	8	J6018-0B	22, 26	J6151-5A	22, 26	J7015-0A	28
J1511-1C	6	J4330-0A	16	J6021-0A	18	J6152-0A	22	J7019-0A	28
J1511-3C	6	J4331-0A	16	J6022-0A	24	J6152-5A	22	J7021-0A	28
J1512-0A	6, 18	J4332-0A	16	J6023-0A	20, 24	J6153-0A	26	J7022-0A	28

P、CS-8810D、8820D 零件號碼與頁數對照 NUMERICAL PARTS-LIST

零件號碼 PARTS NO.	頁數 PAGE	零件號碼 PARTS NO.	頁數 PAGE	零件號碼 PARTS NO.	頁數 PAGE	零件號碼 PARTS NO.	頁數 PAGE	零件號碼 PARTS NO.	頁數 PAGE
J7023-0A	28	RU20UC05	28	WA089008	22, 26	ZMA05002	24	ZMB04029	10
J7024-0A	28	T1070-0A	10	WA089009	22, 26	ZMA06001	22	ZMB04030	20
J7025-0A	28	T1070-1A	10	WA089013	22, 26	ZMA06002	14, 18, 22	ZMB04035	6, 12
J7026-0A	28	T1320-0A	8	WA089015	6	ZMA06002	26	ZMB05002	10
J7030-0A	28	T1320-3A	8	WA099002	6	ZMA06003	8, 12, 22	ZMB05003	2, 4
J7031-0A	28	T1322-0A	8	WA099003	6	ZMA06003	26	ZMB05004	2, 14
J7032-0A	28	T3022-0A	8	WA099004	6	ZMA06004	22, 26	ZMB05005	10, 14
J7033-0A	28	T4130-0A	8	WA099005	6	ZMA06021	12	ZMB05006	12
J7034-0A	28	T4300-0A	16	WA120009	12	ZMA07001	8	ZMB05017	2
J7035-0A	28	T4301-0A	16	WA129001	12	ZMB02501	4	ZMB06003	10
J7036-0A	28	T4371-0A	16	WA149002	22	ZMB02502	4	ZMB06004	18
J7037-0A	28	T4377-0A	16	WA149005	22	ZMB03002	10	ZMB06007	6, 14
J7050-0A	28	T4378-0A	16	WA159001	14	ZMB03003	20, 24	ZMB07001	8
J7050-1A	28	T7018-3A	2	WA170009	8	ZMB03004	22	ZMC02502	6
OBM00020	6, 18	TLA040	28	WA269001	22, 26	ZMB03004	26	ZMC02505	18
OPP0193400	2	TRB04x05	28	XB110002	10	ZMB03011	2, 18	ZMC03001	2, 18, 20
RA200160	6	VJM6657-04	28	XB116002	6, 18, 20	ZMB03032	28	ZMC03001	24
RA200220	18, 20	VJPV125-5	28	XB314001	10	ZMB04005	20	ZMC04001	2, 18, 20
RA200260	22, 26	VJT6657-B1	28	XB400002	10	ZMB04006	10	ZMC04012	2
RB200120	12	VMV156-1A	28	XB400003	22, 26	ZMB04008	18, 20	ZMC04022	22, 26
RB200150	14	VW023060	28	YA015060	16	ZMB04009	2, 12	ZMC05001	2
RB200170	8	WA029002	6	YA025117	6	ZMB04010	24	ZMC05002	22, 26
RB200240	14	WA029003	6	YA040156	28	ZMB04012	10	ZMC06002	8
RB300080	6	WA029004	6	YA050168	12	ZMB04013	18, 20	ZMD04001	12
RB500080	8	WA040007	20	YA050420	28	ZMB04014	18, 20	ZMD04002	8
RC100085	6	WA050011	2, 8	YB040025	10	ZMB04015	6, 18, 20	ZMD05001	8
RE000030	2, 16	WA050020	2	ZMA02501	6, 18	ZMB04016	2, 14, 22	ZMD05003	14
RE000040	12, 16	WA059010	18	ZMA04001	8	ZMB04016	26	ZMD06001	28
RE000070	16	WA089005	8	ZMA04003	18	ZMB04017	4	ZMG02502	6
RE000080	6	WA089006	22, 26	ZMA04005	22, 26	ZMB04021	20	ZMG03501	4
RU010100	28	WA089007	22, 26	ZMA05002	08, 18, 20	ZMB04022	4	ZMG06004	12

P、CS-8810D、8820D 零件號碼與頁數對照 NUMERICAL PARTS-LIST

零件號碼 PARTS NO.	頁數 PAGE	零件號碼 PARTS NO.	頁數 PAGE	零件號碼 PARTS NO.	頁數 PAGE	零件號碼 PARTS NO.	頁數 PAGE	零件號碼 PARTS NO.	頁數 PAGE
ZMG06005	16	ZMK06002	12						
ZMH03001	18	ZMK08001	12						
ZMH04001	2, 4	ZML04001	20						
ZMH04005	18	ZML05002	4, 16						
ZMH04007	28	ZML06001	12, 28						
ZMH05001	16	ZMN06001	4						
ZMH05002	2, 12	ZMQ04010	2						
ZMH05003	8	ZMT04003	28						
ZMH05006	18	ZSB08008	10						
ZMH05006	12	ZSB08025	10						
ZMH06001	22, 26	ZSB09037	16						
ZMH06002	8	ZSB11040	16						
ZMH06003	12, 16	ZSD20007	28						
ZMH06004	8	ZSL09002	16						
ZMH06005	10, 22, 26								
ZMH06006	8, 14, 16								
ZMH06006	22, 26								
ZMH06007	10, 14								
ZMH06008	8								
ZMH06010	16								
ZMH06013	16								
ZMJ04001	16								
ZMJ05002	8, 18								
ZMJ05005	8								
ZMJ05008	14								
ZMJ05010	2								
ZMJ05017	2								
ZMJ06001	12								
ZMJ06002	18, 20, 24								
ZMJ06011	16								
ZMK05002	16								