



PARTS BOOK

SC(D)(T) 9200 Series

SC(D)(T) 9300 Series

High-Speed Over Lock

Sewing Machine

PME-131125

Information

A. Parts Book 구성

Structure of Part Book

① **A** Arm, Bed & Machine Body Mechanism
팔, 침대 및 의장품 관계

②

③

④ ⑤ ⑥ ⑦ ⑧ ⑨

Ref. No.	Parts No.	Note	Name of Parts	중 명	Q'ty	Assembly No.
A-1	01-12841-03		Arm	팔	1	
A-2	01-10073-06		Bed	침대	1	
A-4	01-02120-00		Face Plate	면판	1	
A-5	01-02044-12H		Face Plate Gasket	면판 가스켓	1	
A-6	01-1174-4122		Screw(L) 1/84*mm2	볼트	10	
A-7	01-11011-123D		Rubber Cap For Face Plate	면판 고무캡	2	
A-9	01-00194-123D		Caution S/Screw	경고 스크류	1	
A-8	01-011973-00		Turn-up Lever Cover	날리기 PWA	1	
A-10	01-02030-00		Screw(S) 1/84*mm2	볼트(S) 1/84*mm2	1	
A-11	01-01746-00		Bed Cover(L)	침대 커버(좌)	1	
A-12	01-01441-123H		Bed Cover (Gasket,L)	침대 커버 가스켓(좌)	1	
A-13	01-02643-123D		Screw(L) 1/84*mm2	볼트(L) 1/84*mm2	14	
A-13-1	45-0244-1002		Washer	와셔	2	
A-14	01-01732-00		Bed Cover(S)	침대 커버(우)	1	
A-15	01-01734-123H		Bed Cover (Gasket,R)	침대 커버 가스켓(우)	1	
A-16	440211-100H		Tank Rubber Cap	고압 탱크 고무캡	1	
A-17	01-0274-123D		Thread (Slide with Three Poles)	세극용 슬라이드(조)	15Set	
A-19	01-02101-123D		Thread (Slide(L))	면판 슬라이드(조)	1	
A-20	01-02102-123D		Thread (Slide(R))	면판 슬라이드	3	
A-21	01-01000-123D		Thread (Slide(S))	면판 슬라이드	1	
A-22	01-01643-00		Arm Thread Guide Assy	팔용 슬라이드 슬라이드조	1	
A-23	11-01735-752D		Nut	너트	1	
A-24	01-02103-123H		Thread (Slide(S))	면판 슬라이드(조)	1	
A-25	0102070-100H		Siscon Tank Assy	슬리콘 탱크 용액조	15Set	
A-26	0102060-100H		Siscon Tank	슬리콘 탱크 용액통	1	
A-27	0102065-100H		Siscon Oil Window	슬리콘 유량창	1	
A-28	0102400-100H		Siscon Part	슬리콘 부품 용액 통	1	
A-29	01-13053-00		Part for Siscon Oil Supply	슬리콘 기름 공급 부품	1	
A-30	01-02164-123D		Screw(L) 1/84*mm2	볼트(L)	1	
A-32	04-12410-123D		Arm Upper Part Rubber Cap	팔용 상부 고무 캡	2	
A-33	04-02101-123H		Needle Bar Rubber Cap	바늘봉 고무 캡	1	
A-34	01-04210-142L		Rubber Cap(L)	고무캡(좌)	4	
A-35	44-02110-742D		Rubber Cap(S)	고무캡(중)	7	
A-36	01-01736-123H		Bed Rubber	침대 고무	1	
A-37	01-019817-00		Welder (Sticker,R)	인쇄 스티커-우측용	1	
A-38	01-019818-00		M Welder (Sticker,M)	인쇄 스티커-중용	1	
A-39	01-019819-00		L Welder (Sticker,L)	인쇄 스티커-좌측용	1	
A-40	01-019820-00		K Welder (Sticker,K)	인쇄 스티커-K용	1	
A-41	01-02110-123D		Screw(L) 1/84*mm2	볼트(L)	2	
A-42	01-02114-123H		Tap Cover	탭 커버	1	
A-43	41-1014-123H		Siscon Winder Assy	슬리콘(조)	15Set	
A-44	41-10015-100H		Siscon Winder (Base Assy)	슬리콘 권취기(조)	1	
A-45	41-10054-123H		Siscon Winder (Shaft)	슬리콘 구동축	1	
A-46	01-02090-00	S. Color	Sticker(S)	인쇄 스티커-색용	1	
A-47	01-02070-750D		Screw(S)	볼트(S)	1	
A-48	41-10005-100H		Siscon Winder	슬리콘 권취기	1	
A-49	01-0104-550T		Screw(L) 1/84*mm2	볼트(L)	2	
A-50	41-10003-100H		Siscon Winder Action Ring	슬리콘 작동링	1	
A-51	41-10004-100H		Siscon Winder Shaft Rubber Ring	슬리콘 구동축 고무링	1	
A-52	41-10010-100H		Siscon Winder Lever	슬리콘 PWA	1	
A-53	41-10011-100H		Siscon Winder Adjusting Plate	슬리콘 조정판	1	
A-54	01-01130-123D		Screw(L) 1/84*mm2	볼트(L)	1	
A-55	01-01194-123D		Washer	와셔	1	
A-56	41-10013-100H		Siscon Winder Lower Shaft	슬리콘 하부 축	1	
A-57	41-10014-100H		Siscon Winder Adjusting Term	슬리콘 조정 용	1	
A-58	0102150-04113		Screw(M) 1/84*mm2	볼트(M)	1	

Note: P= Heavy Material(중량재), M=Medium Material(중량재), MA= Pneumatic Heavy Material(공압식 중량재)
L= Light Material(저중량재), K=Roll Material(롤재), EL=Large Shuble Hole(대 시틀 홀)

①: 관계 별 고유 코드

Unique code by mechanism

②: 관계 별 고유 명칭

Unique name by mechanism

③: 관계도

Explode view

④ Ref.No.: 파트별 고유 식별 번호

Unique identification number by part

⑤ Parts No.: 고유 제품 코드

Unique Product code

Ex)

구분 Category	Code	비고 remarks
구 부품 Old part	01-030C-1230	
신 부품 New Part	AS-000000-00	조(組) 파트 Set parts
	GP-000000-00	기구적 파트 Instrumental parts
	EP-000000-00	전기적 파트 Electrical parts

⑥ Note: 공지사항 표기 및 메모

Refers to notice and memo

⑦ 품

명: 파트의 고유 품명

Name of Part: Unique name of parts

⑧ Q'ty : 파트의 수량

The number of parts

⑨ Assembly no.: 조(組) 파트의 식별 번호

Unique identification number by set part

Warning

1. 조에 속한 파트는 개별 조립 시 제품의 파손 또는 재봉 불량 발생될 수 있어 해당 파트에 대한 주문 시에는 조 품목으로만 구입이 가능합니다.
2. 본 책자는 Parts Book으로 제작되었으므로 매뉴얼로 사용 불가합니다.
3. 사전 예고 없이 사양이 변경 될 수도 있습니다.

1. The parts classified as ass'y items may cause damage to the machine or bad sewing when they are separately assembled. Hence, when they are ordered, they can be purchased as ass'y items only.
2. This is a parts book. It cannot be used as a manual.
3. Parts are Subject to change in Design Without Prior Notice.

Note

- 썬스타 제품의 부품은 아래 인터넷주소로 접속하시어 신청할 수 있습니다.
<http://www.sunstarcs.com>
- 가입된 회원께서는 썬스타 포탈 사이트에 로그인후 필요한 부품을 신청할 수 있습니다.
- 부품관리-발주관리-발주등록 항목에서 부품번호와 신청수량을 입력하여 등록하시면 발주가 됩니다.
- 부품번호를 모르시는 경우 파츠북 조회를 클릭하시고 사용하는 기종을 검색하여 선택하시면 해당 기종의 파츠북을 조회할 수 있습니다.
- 파츠북은 관계별로 구분되어 있으며 관계를 알고 있다면 부품 찾기가 용이합니다.
- You can make an order for the parts of Sunstar machine to connect internet address.
<http://www.sunstarcs.com>
- You can request for parts you want after login if you are a registered member.
- In parts Management - Order Management - Order Registration entry, you can place an order by entering the part number and quantity.
- If you don't know the parts number, click the parts book menu bar.
In a download list, you can read parts book by searching model you use.
- This parts book is classified by the mechanism, therefore you can find part easily.

MACHINE MODEL

Series Code	
SC92	Over-edge
SCC92	Over-edge + Condensed Stitch
SC93	Safety Stitch
SCT92	Over-edge + Variable Top Feed
SCT93	Safety Stitch + Variable Top Feed
SC94	Over-edge + Cylinder Bed
SCT94	Over-edge + Cylinder Bed + Variable Top Feed
SC95	Double Chain Stitch
SCD92	Direct Over-edge
SCD93	Direct Safety Stitch

Fabric Weight	
1	Extra Light ~ Light
2	Light ~ Medium
3	Medium ~ Heavy
4	Heavy ~ Extra Heavy
5	Very Heavy

Over-Edge Width	
3	3mm
4	4mm
5	5mm
6	6mm
7	7mm

Pitch of Feed Dog Teeth	
1	1mm
2	1.25mm
3	1.6mm
4	2mm
5	2.5mm

Needle Space	
0	1-Needle
2	2mm
3	3mm
5	5mm

SC92 04 N - 0 4 / 2 3 3 - 3 × 5

Stitch Type			
41	#401	12	#512
03	#503	14	#514
04	#504	15	#515
05	#505	16	#516

N	Wrinkle-Free
---	--------------

Operation	
0	Plain Seaming
1	Blind Stitch Hemming
2	Serging
3	Turn Up Down Hemming
4	Shirring
5	Attaching Tape
8	Back Tacking
9	Versatile

Lift	
2	Standard
3	High
4	Extra-high
5	Ultra-high

Rows of Feed Dogs			
1	1-Row Standard	6	1-Row Special
2	2-Rows Standard	7	2-Rows Special
3	3-Rows Standard	8	3-Rows Special
4	4-Rows Standard	9	4-Rows Special
5	5-Rows Standard	0	5-Rows Special

CONTENTS

목 차

A	Machine Bed Frame Mechanism 베드 프레임 관계	8
B	Cover Mechanism 커버 관계	10
C	Crank Shaft Drive Mechanism 주축 관계	14
D	Thread Tension Mechanism 실조절 장치 관계	16
E	Thread Guide & Thread Take Up Mechanism 실안내 및 실채기 관계	18
F	Needle Drive Mechanism 바늘대 관계	20
G	Upper Looper Drive Mechanism 상루퍼 관계	22
H	Lower Looper Drive Mechanism 하루퍼 관계	24
I	Chain Stitch Looper Mechanism - SC(T) 9300(H) Series Only 체인스티치 루퍼 관계 - SC(T) 9300(H) 시리즈 전용	26
J	Feed Mechanism 피드 관계	28
K	Knife Drive Mechanism 메스 구동 관계	32
L	Presser Foot Mechanism 노루발 관계	34
M	Lubrication Mechanism 급유 관계	36
N	Accessories Mechanism 액세서리 관계	40
01	Exclusive Parts for SC 9204-01/223-4 Mechanism 전용부품 관계 SC 9204-01/223-4	42
02	Exclusive Parts for SC 9204-02H/223-3 Mechanism 전용부품 관계 SC 9204-02H/223-3	44
03	Exclusive Parts for SC 9214-03/333-2X3 Mechanism 전용부품 관계 SC 9214-03/333-2X3	46
04	Exclusive Parts for SC 9212-02/333-2X5 Mechanism 전용부품 관계 SC 9212-02/333-2X5	48
05	Exclusive Parts for SC 9316-03/233-3X5 Mechanism 전용부품 관계 SC 9316-03/233-3X5	50
06	Exclusive Parts for SC 9316-03_333-5X5 Mechanism 전용부품 관계 SC 9316-03_333-5X5	54
07	Exclusive Parts for SC 9344-A04/435-5X3X4 Mechanism 전용부품 관계 SC 9344-A04/435-5X3X4	58
08	Exclusive Parts for SC 9316-A04/435-5X5 Mechanism 전용부품 관계 SC 9316-A04/435-5X5	64
09	Exclusive Parts for SC 9316H-A05/535-5X5 Mechanism 전용부품 관계 SC 9316H-A05/535-5X5	70
010	Exclusive Parts for SCT 9316-A04/435K-5X5 Mechanism 전용부품 관계 SCT 9316-A04/435K-5X5	76

CONTENTS

목 차

011	Exclusive Parts for SCT 9316-03/233-5X5 Mechanism 전용부품 관계 SCT 9316-03/233-5X5	●.....	84
012	Exclusive Parts for SCT 9214-03/333-2X4 Mechanism 전용부품 관계 SCT 9316-A04/435K-5X5	●.....	92
013	Exclusive Parts for SCD 9200 Mechanism 전용부품 관계 SCD 9200	●.....	98
P	Gauge Parts 게이지 파트	●.....	102
Q	Top Feed Mechanism - SCT 9200/9300 Series Only 상피드 관계 - SCT 9200/9300 시리즈 전용	●.....	104
R	Fully Submerged Type Table Mechanism 내림 테이블 관계	●.....	110
S	Edge Guide Mechanism (Option) 모서리 가이드 관계 (선택사양)	●.....	112
	Index 인덱스	●.....	114

A

Machine Bed Frame Mechanism

베드 프레임 관계

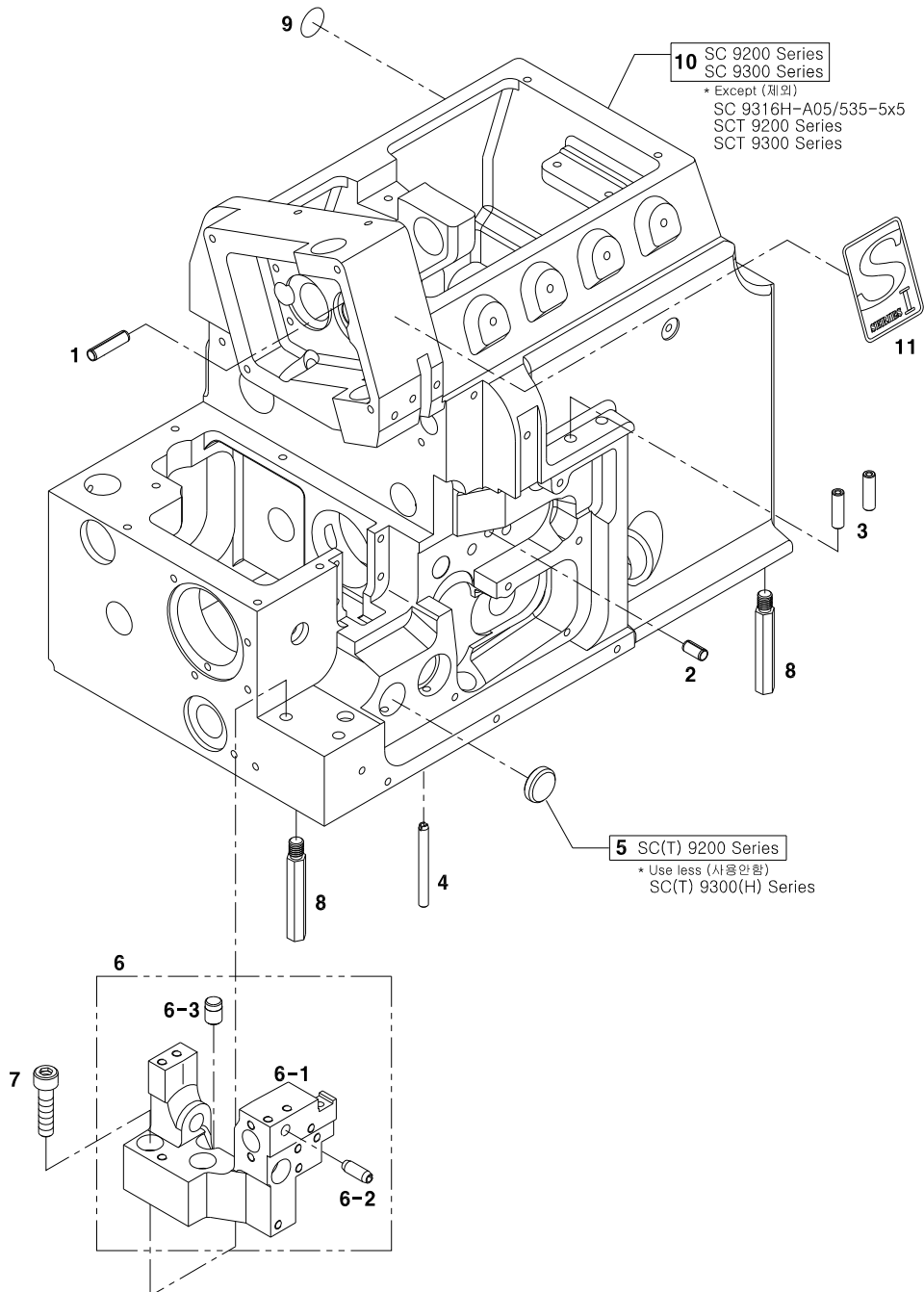

B

Cover Mechanism

커버 관계

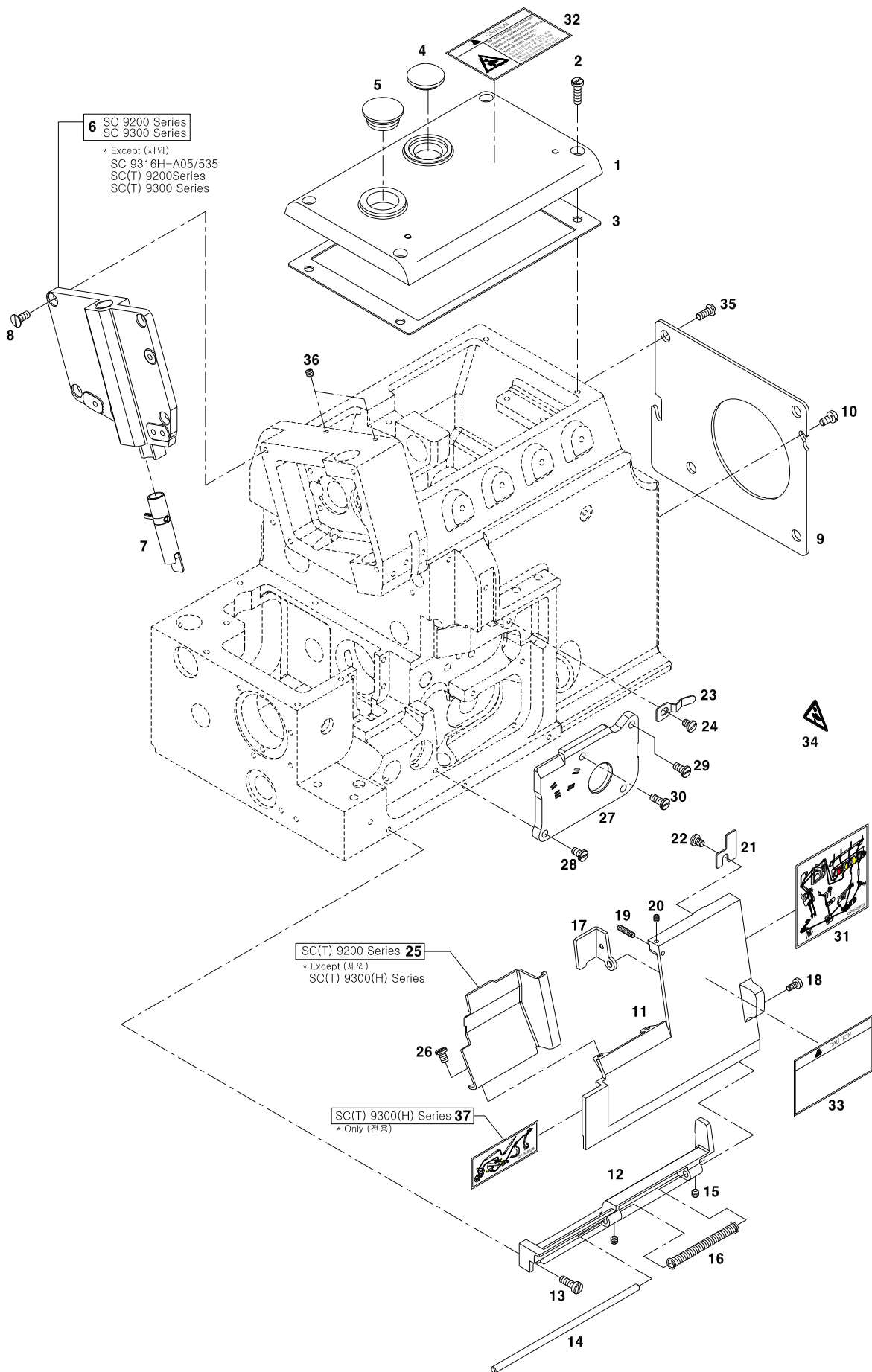

Ref. No.	Parts No.	Note	Name of Parts	품 명	Q'ty	Applied Period
B-1	CMB-LA004400		Top Cover	윗뚜껑	1	
B-2	PSC-AC006200		Screw	나사	4	
B-3	CMB-FC002500		Gasket	윗뚜껑 가스켓	1	
B-4	CLB-JJ000200		Oil Sight Window	유창	1	
B-5	DPK-CB001601		Plug	고무마개	1	
B-6	CMB-LA017302		Face Cover	면판	1	Feb.27.12
	CMB-LA004500		Face Cover	면판	1	
B-7	APB-PS000100		Presser Bar Assy.	누름대 (조)	1Set	
B-8	DSC-BB004100		Screw	나사	4	
B-9	CMB-LA005300		Fan Cover	팬 커버	1	
B-10	DSC-BF005400		Screw	나사	2	
B-11	CMB-LA005500		Front Cover (Right)	전면커버 (우)	1	
B-12	CMB-BB004000		Hinge	전면커버(우) 힌지	1	
B-13	DSC-BF004100		Screw(M4×L12)	나사	3	
B-14	DPN-AA002400		Pin	전면커버 (우) 힌지 핀	1	
B-15	PSC-CB000200		Screw	나사	2	
B-16	DSP-AA002200		Spring	전면커버 (우) 스프링	1	
B-17	CMB-BB003900		Latch	스토퍼 레치	1	
B-18	DSC-BF003900		Screw	나사	1	
B-19	DSC-CB001300		Screw	나사	1	
B-20	DSC-CA001400		Screw	나사	1	
B-21	CMB-BJ002300		Latch	전면커버 (우) 레치	1	
B-22	DSC-BJ001900		Screw	나사	1	
B-23	DSP-AD000700		Flat Spring	레치고정 판 스프링	1	
B-24	DSC-BF005400		Screw	나사	1	
B-25	CMB-LA005400		Front Cover (Left)	전면커버 (좌)	1	
B-26	DSC-BF005000		Screw	나사	2	
B-27	CMB-LA005200		Cover	실채기 몸체	1	
B-28	DSC-BF005400		Screw	나사	2	
B-29	DSC-BF004100		Screw(M4×L12)	나사	1	
B-30	DSC-BF004100		Screw	나사	1	
B-31	CMB-LD008700		Threading Diagram 1	실길 안내 스티커 1	1	
B-32	CMB-LD006000		Caution Label	경고스티커	1	
B-33	CMB-LD005900		Caution Label	위험표시스티커	1	
B-34	CMB-LD006100		Label	주의 스티커	1	
B-35	DSC-BF000700		Screw	나사	3	
B-36	SC-001234-00		Screw	나사	2	
B-37	CMB-LD004600		Threading Diagram 2	실길 안내 스티커 2	1	
B-38	AMB-PS001200		Cloth Plate Ass'y (Wide)	천 이송판 (조)	1Set	
B-39	DBS-DB001400		Bushing	천 이송판 (조) 부상	1	
B-40	PSC-CB000200		Screw	나사	1	
B-41	DWS-CC000100		Washer	파형와셔	1	
B-43	DSC-FA004800		Screw	나사	1	
B-44	CMB-FD000900		Cushion Rubber	쿠션 고무	1	
B-45	AMB-PS001300		Side Cover (Wide)	측면 커버(조)	1Set	
B-46	PSC-BA001300		Screw	나사	1	
B-47	PWS-CA001400		Spring Washer	스프링 와셔	1	
B-48	DSC-BF005400		Screw	나사	2	
B-49	DWS-AA005000		Washer	와셔	2	
B-50	CMB-FD000900		Cushion Rubber	쿠션 고무	1	
B-51	CMB-BB004100		Latch	측면커버 잡이 레치	1	
B-52	DSC-BF005600		Screw	나사	1	
B-53	CMB-LA005800		Plate	침판베이스 커버	1	
B-54	DSC-BB001100		Screw	나사	2	
B-55	CMB-CM000101		Lever	천 이송판 레버	1	Jan.18.12
B-56	DSC-GA000200		Screw	천 이송판 레버 단나사	1	
B-57	DSP-AC001300		Spring	레버 스프링	1	

B

Cover Mechanism

커버 관계

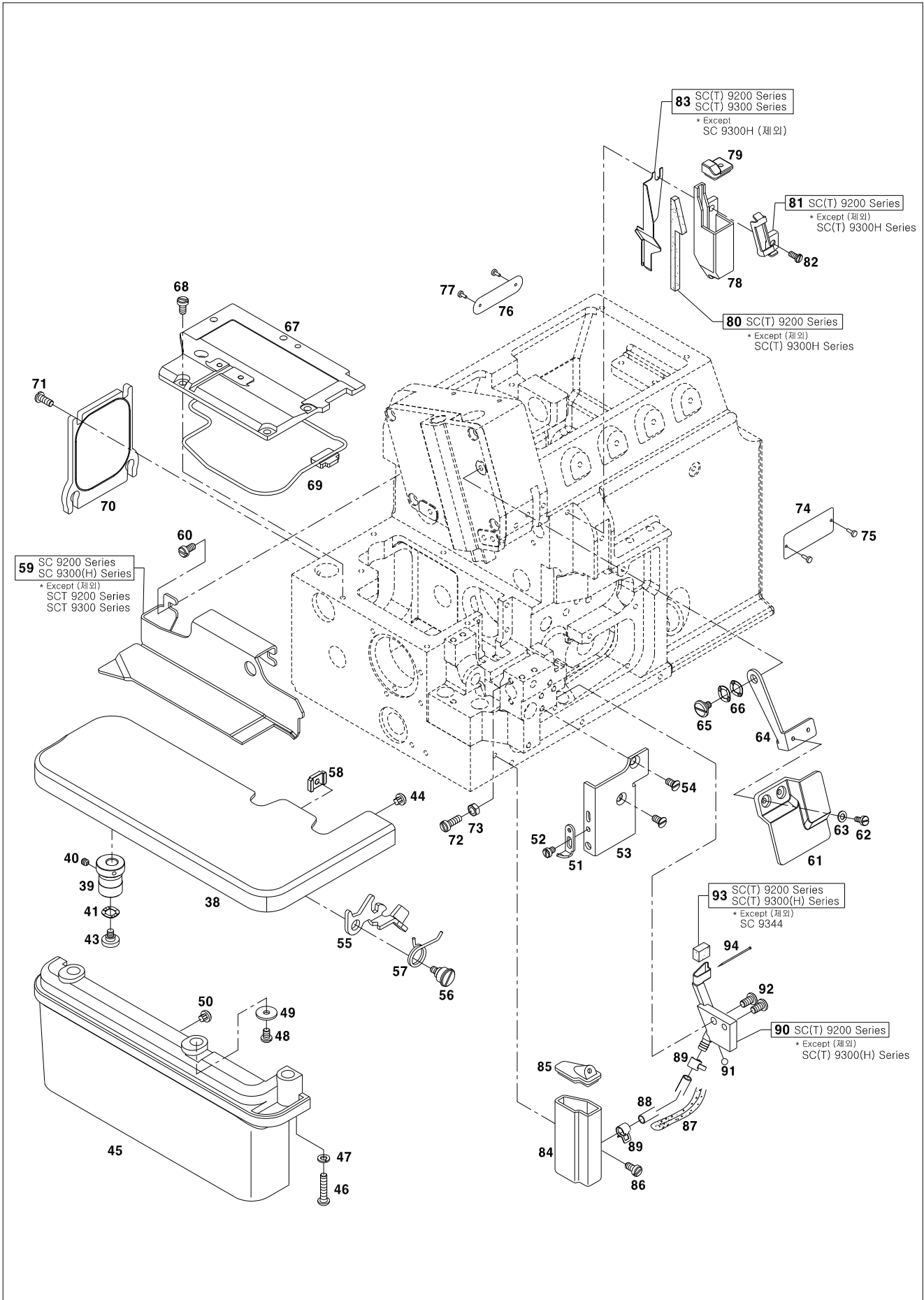

C

Crank Shaft Drive Mechanism

주축 관계

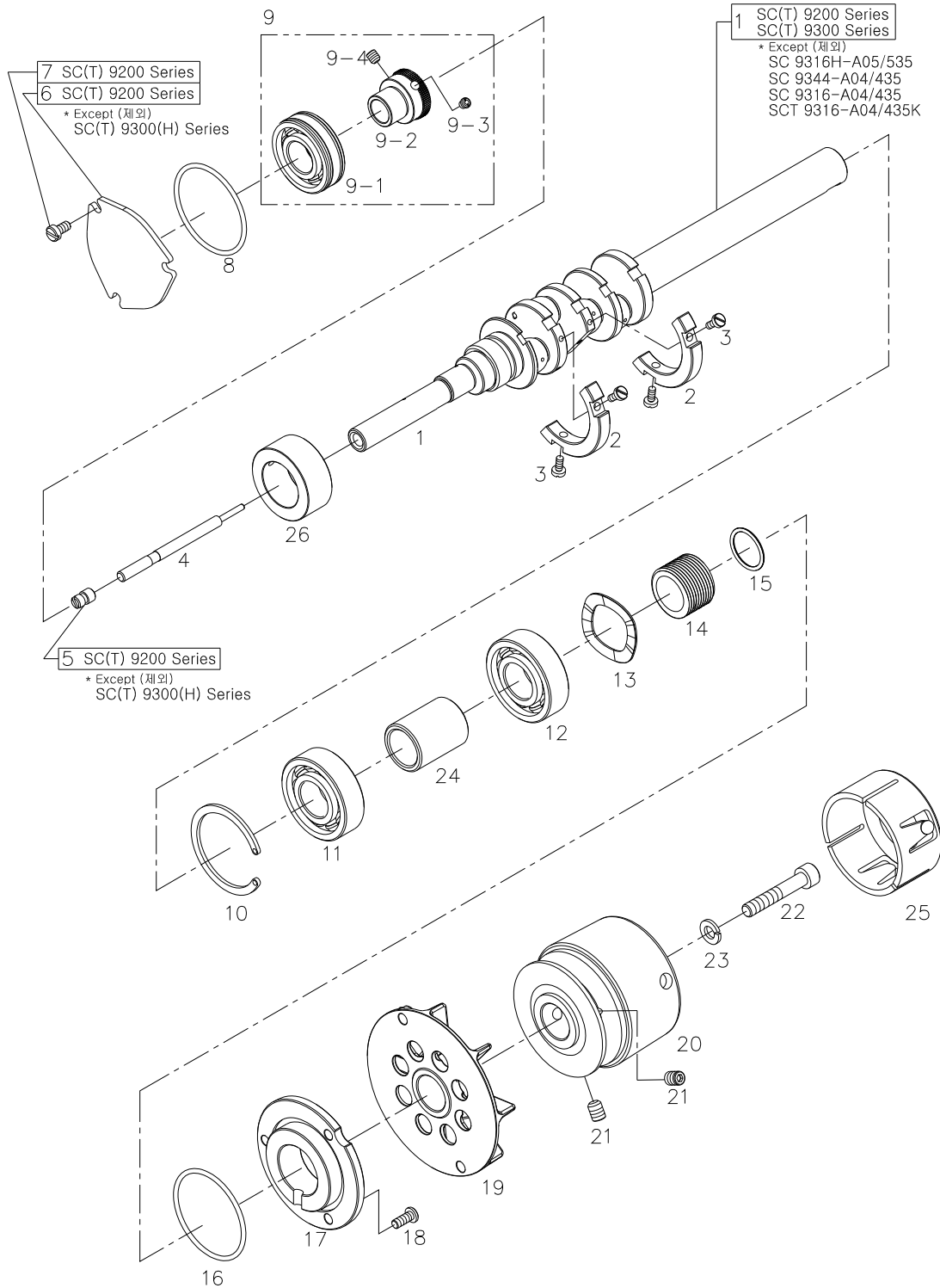

D

Thread Tension Mechanism

실조절장치 관계

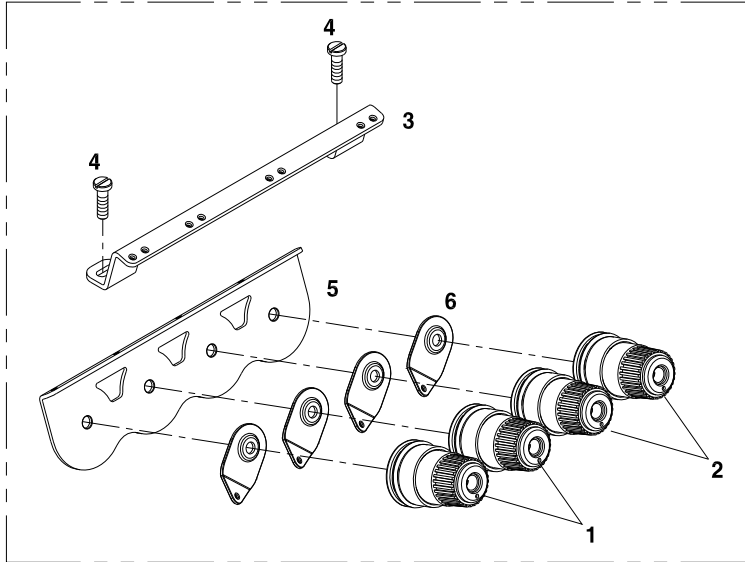
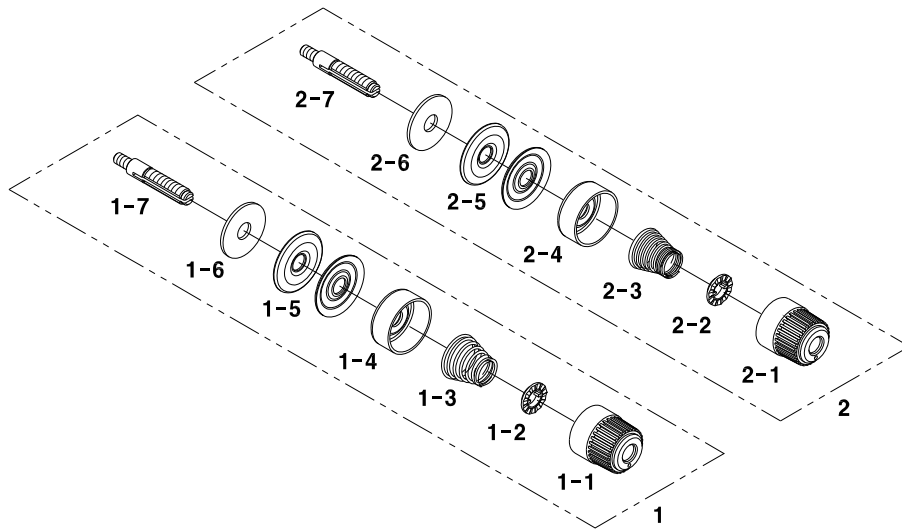

* Except (제외)
 SC 9204-01
 SC 9204-02H
 SC 9316H-A05
 SC 9344-A04
 SC 9316-A04
 SCT 9316-A04

Needle Drive Mechanism

바늘대 관계

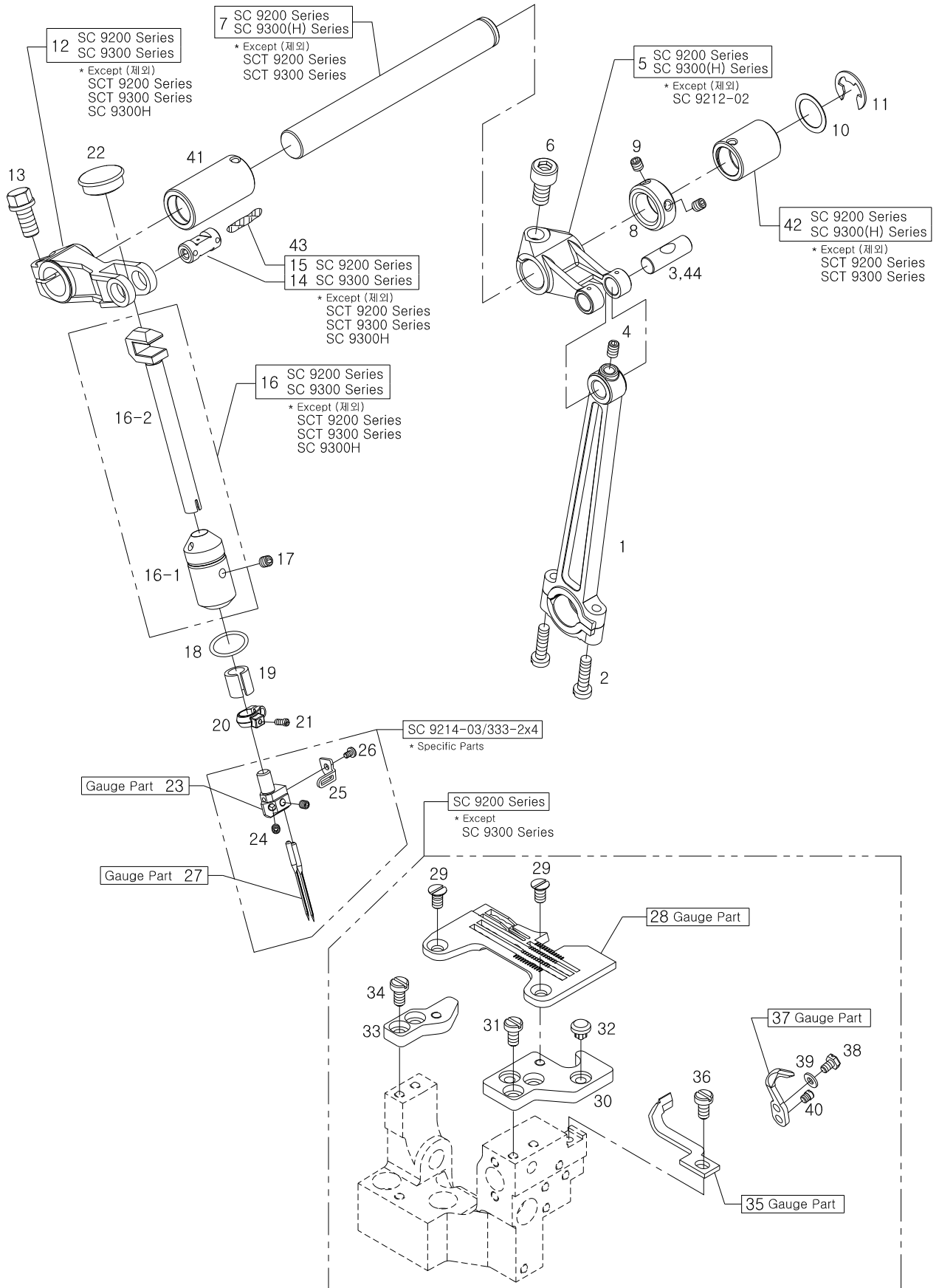

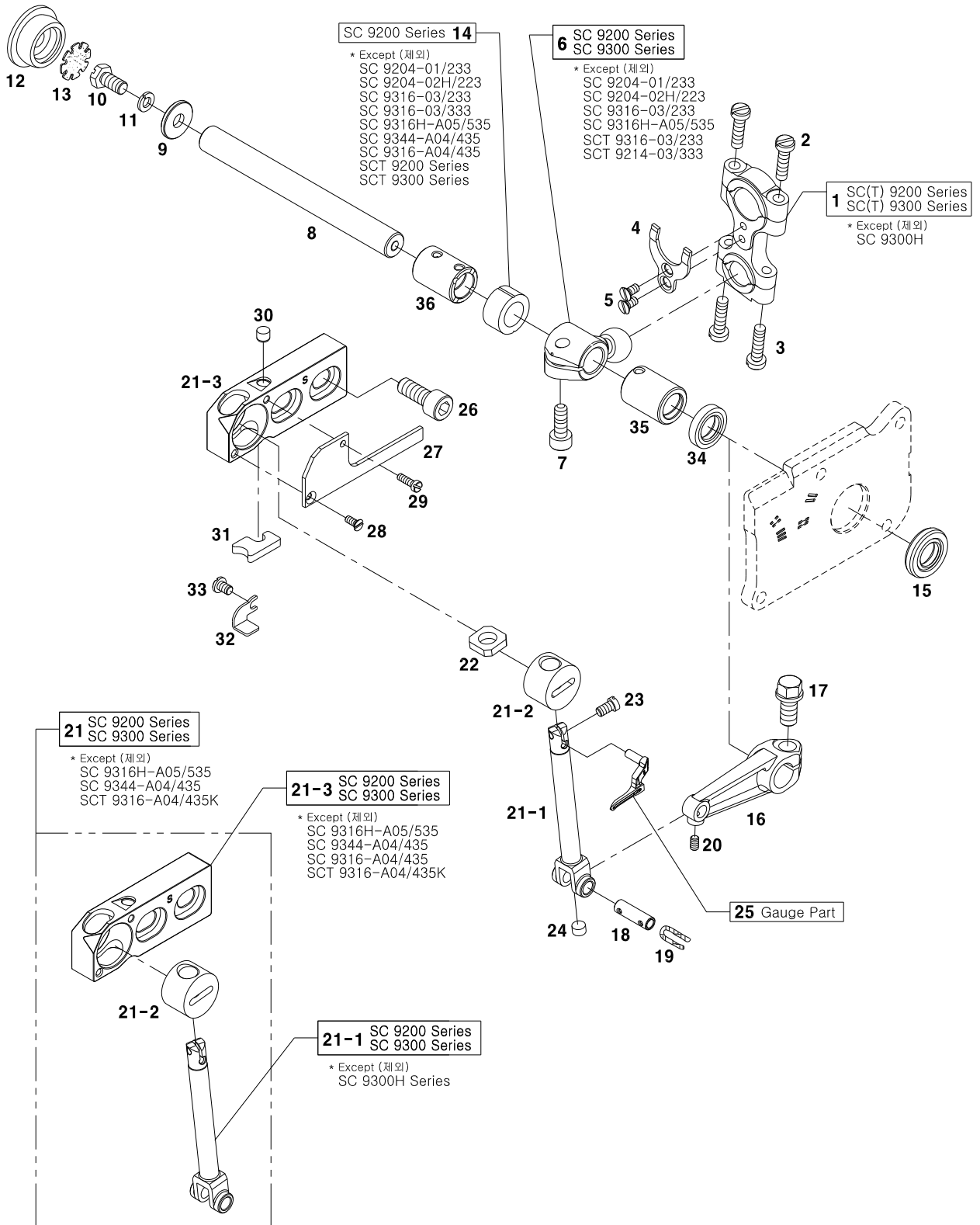



Lower Looper Drive Mechanism

하루퍼 관계

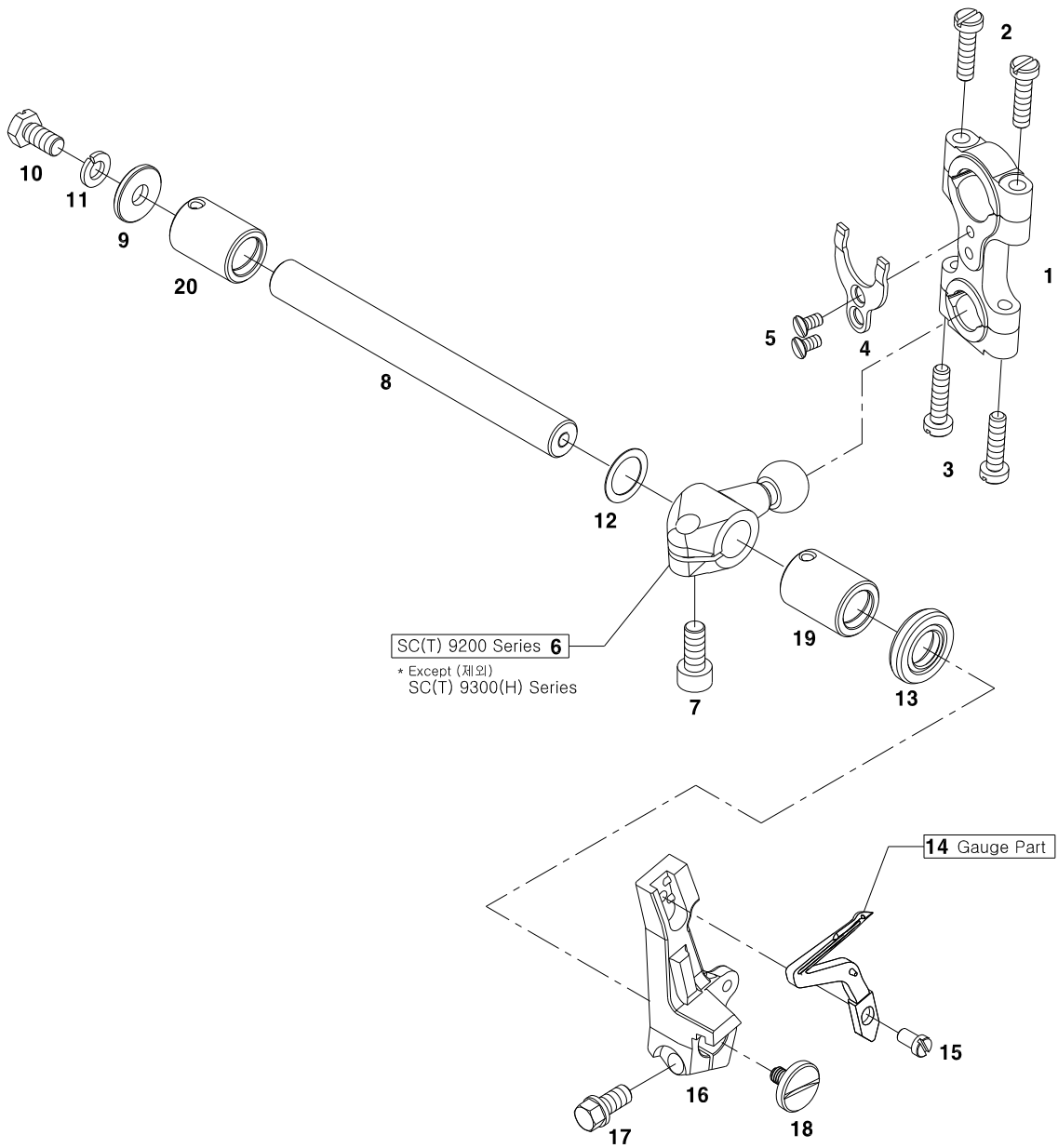

Chain Stitch Looper Mechanism - SC(T) 9300(H) Series Only

체인 스티치 루퍼 관계 - SC(T) 9300(H) 시리즈 전용

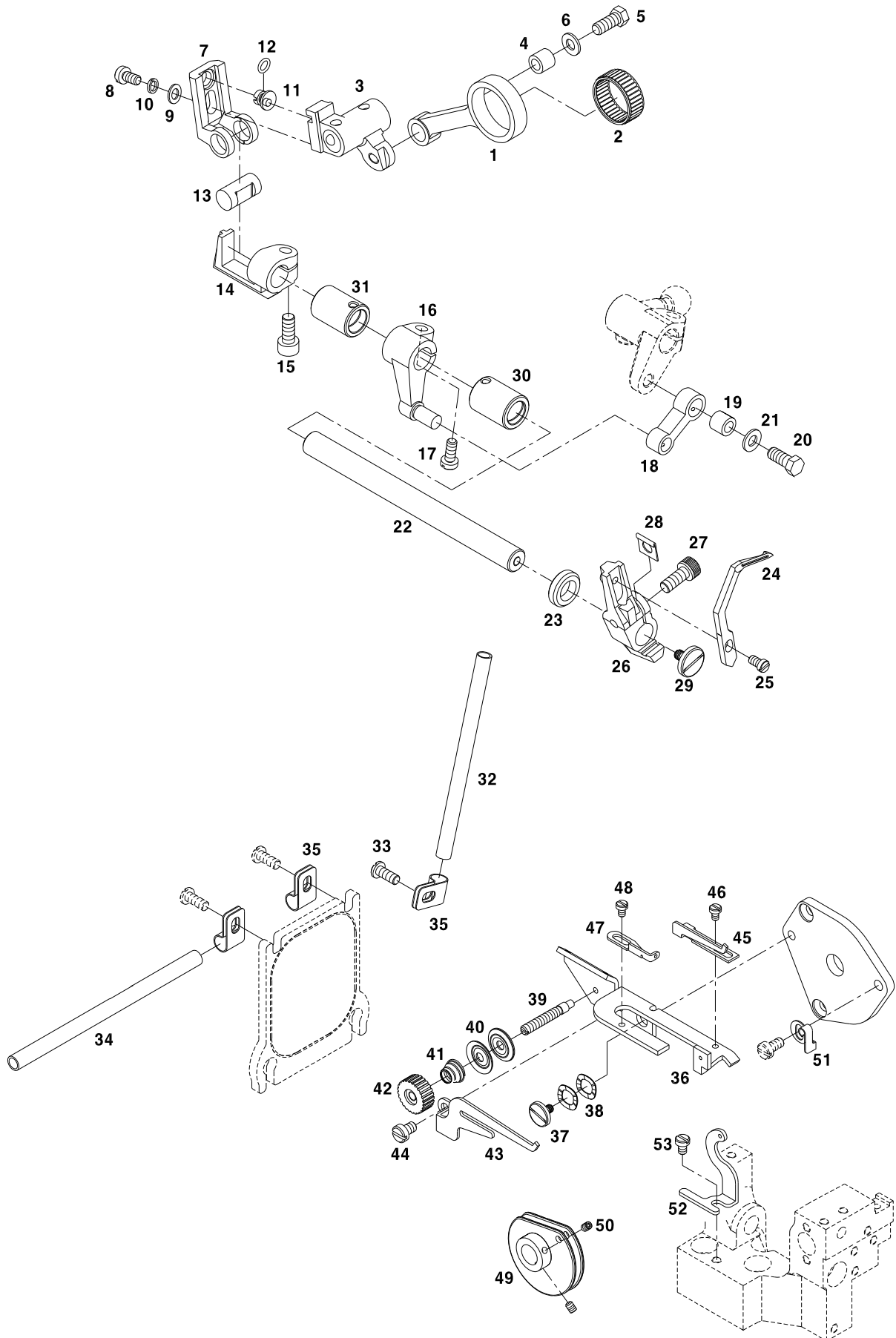



Ref. No.	Parts No.	Note	Name of Parts	품 명	Q'ty	Applied Period
I-1	CLP-CC000300		Looper Connection Rod	루퍼 연결로드	1	
I-2	PBR-BF000501		Needle Bearing	니들베어링(22x18x7.7)	1	
I-3	CLP-CB000200		Looper Slide Crank	루퍼 슬라이드 크랭크	1	
I-4	DBS-DA004902		Bushing	연결 부싱	1	
I-5	DSC-FB002601		Screw	나사(M5xP0.5 L=12)	1	Feb.23.12
I-6	DWS-AA004501		Washer	와셔	1	
I-7	CLP-CD000200		Looper Slide	루퍼 슬라이더	1	
I-8	10-026S-9677		Screw	나사	1	
I-9	PWS-AA000900		Washer	와셔	1	
I-10	DWS-CA000100		Spring Washer	스프링와셔(Ø5)	1	
I-11	CLP-KC000800		Looper Adjustment Shaft	루퍼 조절축	1	
I-12	PPK-BB000300		O-Ring	O-링	1	
I-13	CLP-KC000900		Slide Shaft	슬라이드 축	1	
I-14	CLP-BF001000		Looper Slide Holder	루퍼 슬라이드 잡이	1	
I-15	DSC-AC000200		Screw	나사	1	
I-16	CLP-CB000100		Looper Driving Crank	루퍼 구동 크랭크	1	
I-17	DSC-AC000200		Screw	나사	1	
I-18	CLF-CA000100		Looper Connection Link	루퍼 연결링크	1	
I-19	DBS-DA004902		Bushing	연결링크 부싱	1	
I-20	DSC-FB002601		Screw	나사	1	Feb.23.12
I-21	DWS-AA004501		Washer	와셔	1	
I-22	CLP-KC000700		Looper Shaft	루퍼 축	1	
I-23	DPK-AZ000100		Looper Oil Seal	루퍼 오일씰(Ø10xØ15x3)	1	
I-24	CGA-HD000500		Looper	루퍼	1	
I-25	DSC-BF004900		Screw	나사	1	
I-26	CLP-BF000900		Looper Bracket	루퍼 브라켓	1	
I-27	DSC-AA001700		Screw	나사	1	
I-28	CLP-BJ001800		Looper Bracket Spacer	루퍼 브라켓 스페이서	1	
I-29	DSC-BF004800		Screw	나사	1	
I-30	DBS-DA005600		Bushing	상루퍼 실재기축 전부싱	1	
I-31	DBS-DA005500		Bushing	운동메스 구동축 후부싱	1	
I-32	CTG-BQ000200		Thread Guide Bar A	실안내봉 A	1	
I-33	DSC-BF005400		Screw	나사	1	
I-34	CTG-BQ000100		Thread Guide Bar B	실안내봉 B	1	
I-35	CTG-BG000100		Thread Guide Holder	실안내 잡이	3	
I-36	CTG-BJ001000		Looper Thread Guide	루퍼 실안내	1	
I-37	DSC-FD001600		Screw	나사	1	
I-38	DWS-CC000100		Washer	파형 와셔	2	
I-39	CTA-KF000300		Thread Tension Shaft	실조절 장치 축	1	
I-40	CTA-BJ002900		Tension Disc	실안내 접시	2	
I-41	DSP-BA002700		Tension Spring	실접시 스프링	1	
I-42	ATA-PS004200		Thread Tension Nut Ass'y	실장력 조절 너트(조)	1	
I-42-1	CTA-BF000200		Thread Tension Nut	실장력 조절너트	1	
I-43	CTG-BJ000600		Looper Thread Guide A	루퍼 실안내 A	1	
I-44	DSC-BJ001900		Screw	나사	1	
I-45	CTG-BJ000800		Looper Thread Guide B	루퍼 실안내 B	1	
I-46	DSC-BF005700		Screw	나사	1	
I-47	CTG-BJ000900		Looper Thread Guide C	루퍼 실안내 C	1	
I-48	DSC-BF005700		Screw	나사	1	
I-49	ALP-PS000500		Looper Cam Ass'y	루퍼캠(조)	1	
I-49-1	CLP-DC000200		Looper Cam	루퍼캠	2	
I-49-2	DCL-AA008400		Looper Cam Collar	루퍼캠 카라	1	
I-49-3	DCL-BA001400		Looper Cam Spacer	루퍼캠 스페이서	1	
I-50	DSC-CB001400		Screw	나사	2	
I-51	CTG-BG000200		Thread Guide Plate Holder	실안내판 잡이	1	
I-52	CTG-BJ000700		Looper Thread Guide D	루퍼 실안내 D	1	
I-53	DSC-BF005400		Screw	나사	1	

J

Feed Mechanism

피드 관계

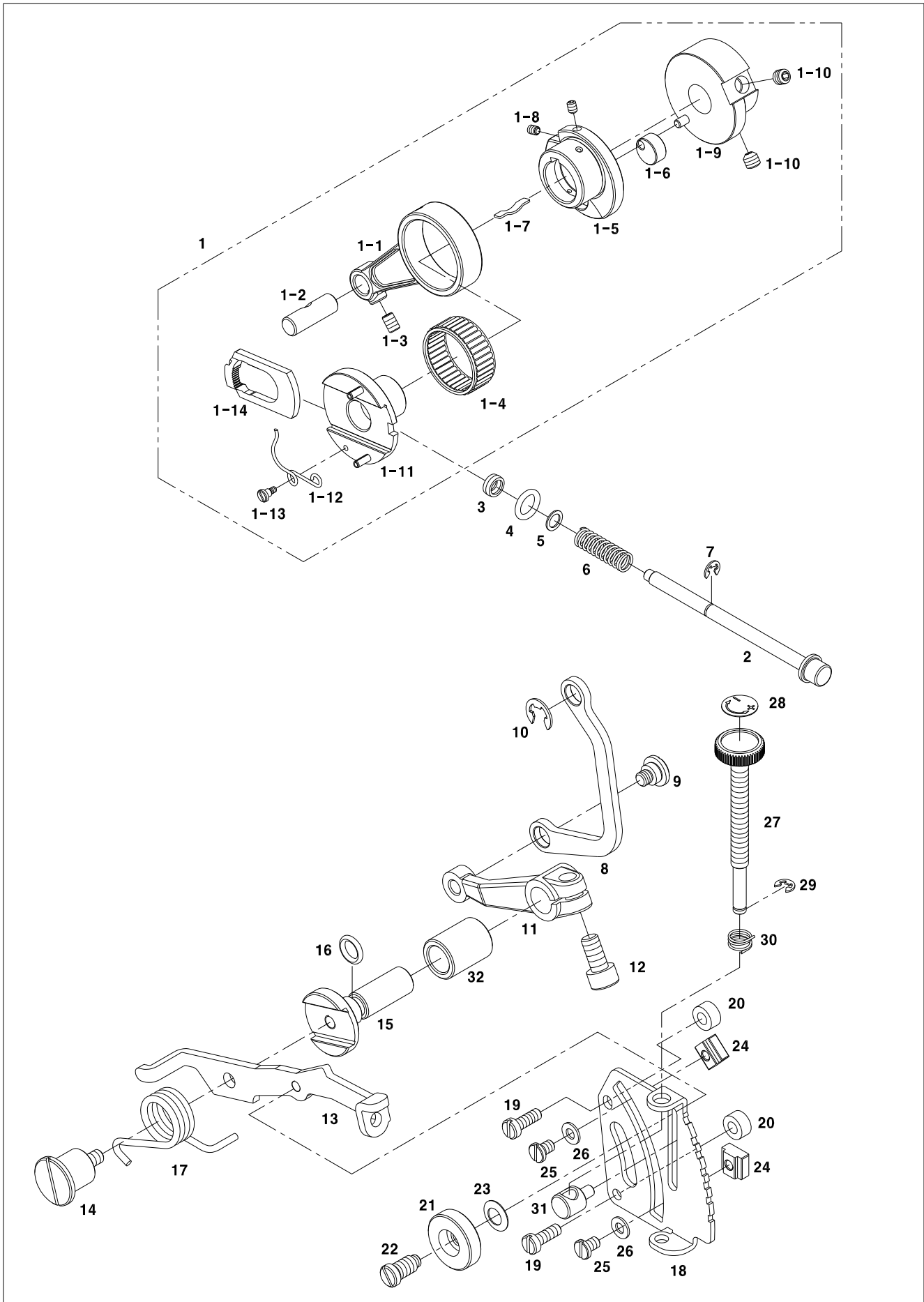

Ref. No.	Parts No.	Note	Name of Parts	품 명	Q'ty	Applied Period
J-1	AS-015866-00		Feed Cam	피드편심캠(조)	1Set	
J-1-1	CFA-CC000100		Connection	피이드 연결롯드	1	
J-1-2	DPN-AA002100		Pin	피이드 연결롯드핀	1	
J-1-3	DSC-CB001200		Screw(M4×L6)	나사	1	
J-1-4	PBR-BA001100		Needle Bearing	피이드 연결롯드 베어링	1	
J-1-5	CFA-DC000200		Eccentric Plate	피이드 편심 판	1	
J-1-6	CFA-DC000300		Guide(Feed Eccentric)	피이드 가이드	1	
J-1-7	DSP-AD000600		Flat Spring	차동이송압력조정판	1	
J-1-8	PSC-CB000800		Screw(M3×L4)	나사(M3×L4)	2	
J-1-9	CFA-DC000400		Regulator	피이드 조절기	1	
J-1-10	DSC-CB000700		Screw(M5×L5)	나사(M5×L5)	2	
J-1-11	CFA-DC000100		Eccentric Cam	피이드 편심캠	1	
J-1-12	DSP-AC001100		Spring	래치 스프링	1	
J-1-13	DSC-FA005100		Screw(M2)	단나사	1	
J-1-14	CFA-CS000100		Ratchet	래치	1	
J-2	DPN-BC000500		Push Button	푸시 버튼	1	
J-3	CFA-FG000100		Gasket	피이드 가스켓	1	
J-4	PPK-BA000400		O Ring	O-링(d=3.8, t=1.9)	1	
J-5	DWS-AA004700		Washer	와셔	1	
J-6	DSP-AA001901		Spring	버튼 스프링	1	
J-7	PSR-AC000400		Ring(Ø3)	E-링(Ø3)	1	
J-8	CFA-CA000100		Link	피이드 링크	1	
J-9	DSC-FA005200		Screw	단나사	1	
J-10	PSR-AC000500		Ring	E-링	1	
J-11	CFA-CB000100		Lever	피이드 레버	1	
J-12	DSC-AC000200		Bolt	나사 (M6×P0.75)	1	
J-13	CFA-CM000101		Lever	피이드 조정 레버	1	
J-14	DSC-FA005300		Screw	단나사	1	
J-15	CFA-BF000100		Holder	차동이송레버잡이	1	
J-16	PPK-BA000500		O Ring	O-링	1	
J-17	DSP-AC001200		Spring	피이드 스프링	1	
J-18	CFA-BJ000100		Regulator Plate	피이드 조정 판	1	
J-19	DSC-BF004100		Screw(M4×L12)	나사	2	
J-20	DCL-BB000900		Spacer	피이드 스페이서	2	
J-21	DSN-CZ000300		Nut	피이드 너트	1	
J-22	DSC-BF005100		Screw	나사	1	
J-23	DWS-CB000100		Spring	접시 스프링	1	
J-24	CFA-CD000100		Stopper	피이드 스톱퍼	2	
J-25	DSC-BF005000		Screw(M4×L6)	나사	2	
J-26	PWS-AA001800		Washer	와셔	2	
J-27	CFA-CR000100		Adjusting Bar	피이드 조정 바	1	
J-28	GP-044402-00		Seal	피이드 라벨	1	
J-29	PSR-AC000400		Ring(Ø3)	E-링 (Ø4)	1	
J-30	DSP-AA002000		Spring	조정 바 스프링	1	
J-31	DPN-AD002800		Pin	조정 바 핀	1	
J-32	DBS-DA005300		Bush for Adjusting Differential Ratio Shaft	차동비 조절축 붓싱	1	
J-33	CLF-KC000100		Shaft	차동이송축	1	
J-34	PSR-AC000900		Ring(Ø7)	E-링	1	
J-35	DPK-CA000900		Plug	리테이너마개	1	
J-36	DWS-AA004400		Washer	와셔	2	
J-37	AS-015868-00		Crank Assy	피이드 크랭크(조)	1Set	
J-37-1	CLF-CB000100		Crank Front	피이드 크랭크(전)	1	
J-37-2	CLF-CB000200		Crank Rear	피이드 크랭크(후)	1	
J-37-3	CLF-CB000300		Crank	차동 조정 크랭크	1	
J-38	DSC-AC000200		Bolt(M6×L12, P0.75)	나사	1	
J-39	PSC-AC006300		Screw(M3×L6)	나사	2	
J-40	CLF-CD000100		Block	차동이송블럭	1	

J

Feed Mechanism

피드 관계

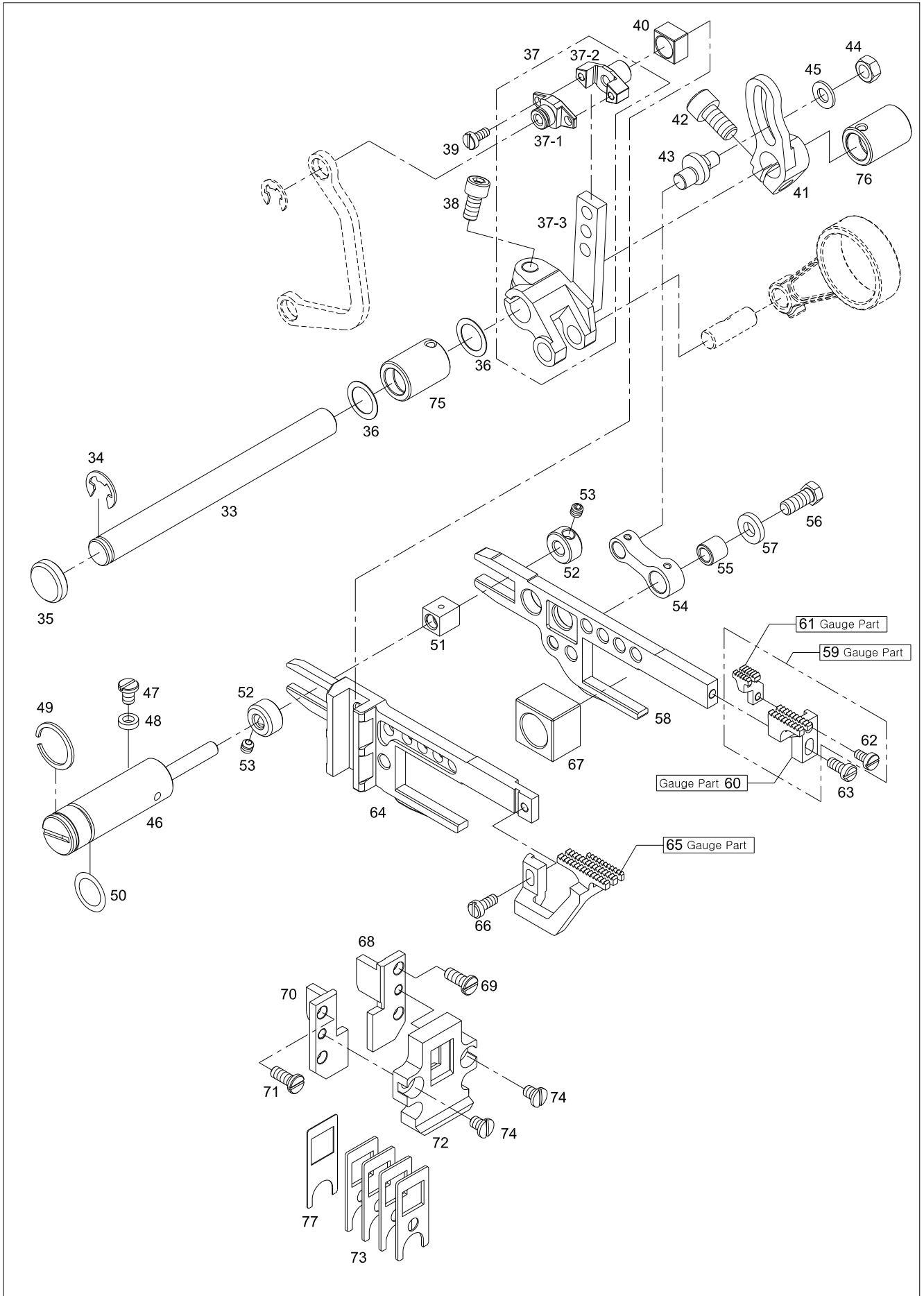

K

Knife Drive Mechanism

메스 구동 관계

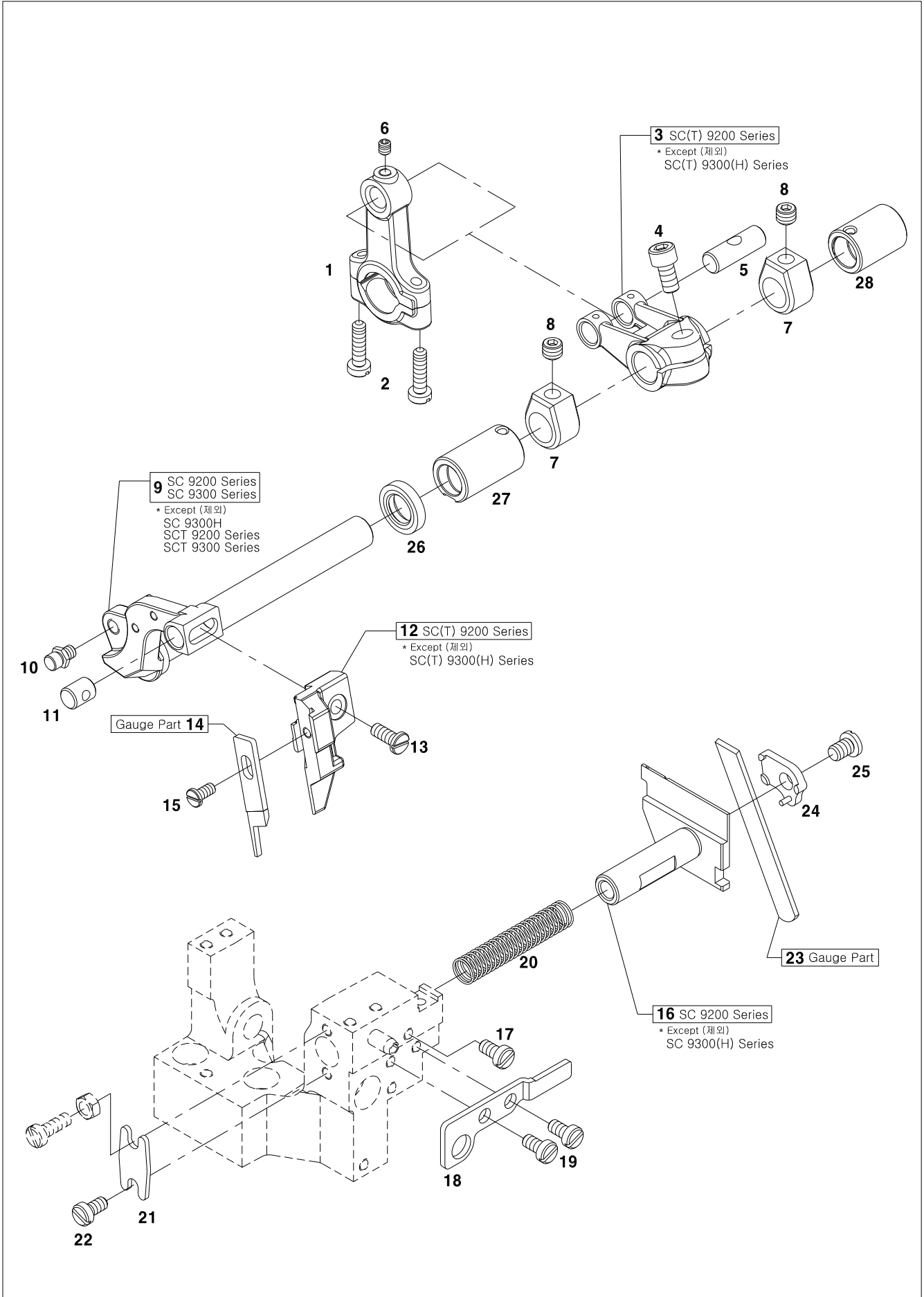



Presser Foot Mechanism

노루발 관계

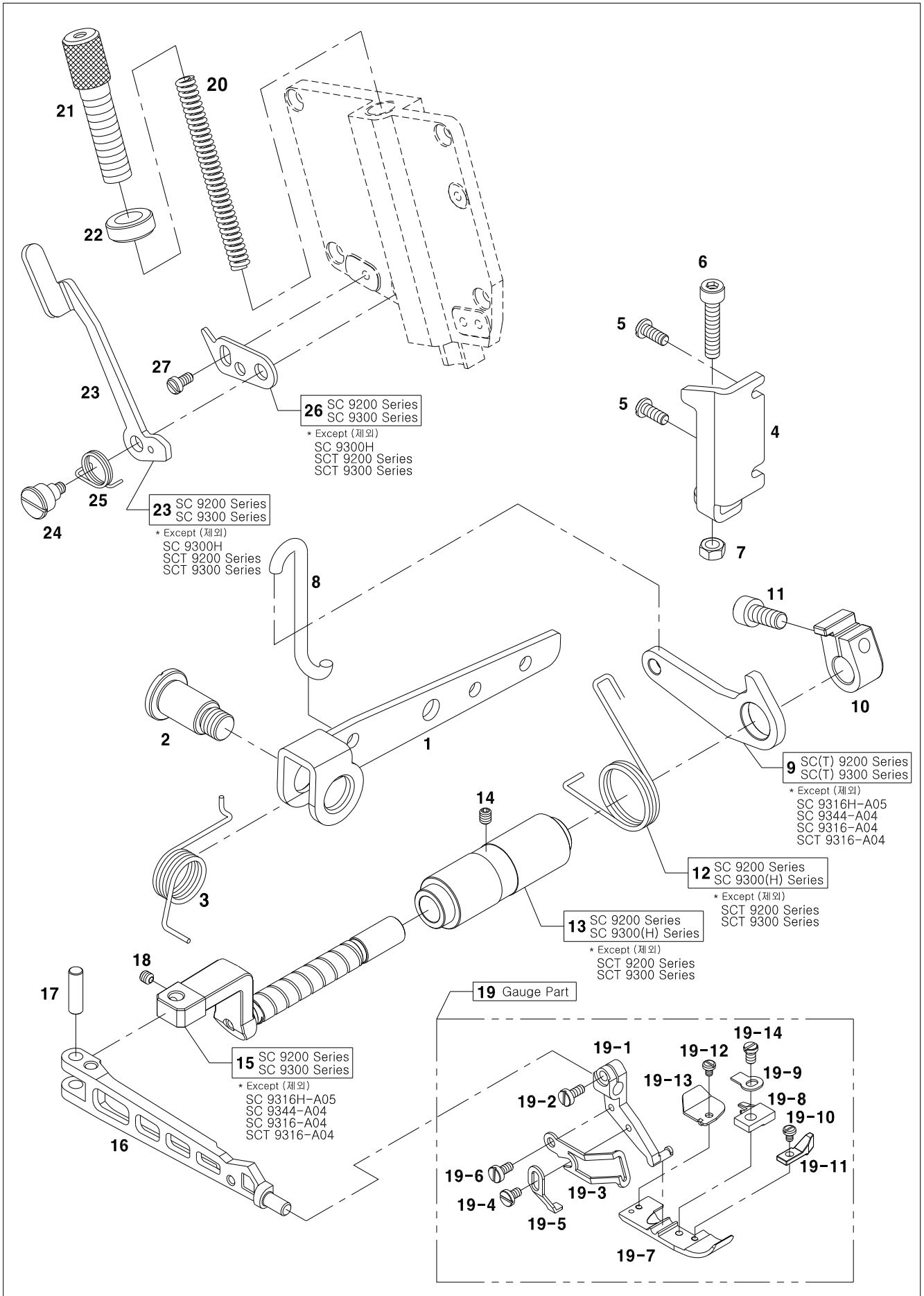



Ref. No.	Parts No.	Note	Name of Parts	품 명	Q'ty	Applied Period
M-1	ALB-PS000100		Pump Ass'y	오일펌프 (조)	1Set	
M-1-1	CLB-BD000100		Pump Housing	펌프 몸체	1	
M-1-2	ALB-PS000200		Rotor (Inside) Shaft	로터(Inside) 축(조)	1	
M-1-3	DGR-AH000100		Worm Wheel	펌프웜휠	1	
M-1-4	DSC-CA001300		Screw	나사	2	
M-1-5	CLB-CT000100		Rotor (Outside)	로터(Outside)	1	
M-1-6	CLB-BJ000300		Oil Pump Cover	오일펌프 커버	1	
M-1-7	DSC-BF004900		Screw	나사(M3.5×P0.6,L=6)	3	
M-1-8	CLB-JM000100		Filter	오일필름망 (내측)	1	
M-1-9	CLB-JM000200		Filter	오일필름망 (외측)	1	
M-1-10	CLB-BL000100		Clamp	오일필름망클램프	1	
M-1-11	DSC-BF003900		Screw	나사	1	
M-1-12	DSN-AA001500		Nut	너트(M3×P0.5)	1	
M-2	PSC-AC006200		Screw	나사	2	
M-3	CLB-JB000100		Tank	오일탱크	1	
M-4	CLB-BB000200		Oil Guide	오일 가이드	1	
M-5	PSC-AC006200		Screw	나사	2	
M-6	CLB-JM000300		Filter Element	오일필터	1	
M-7	CLB-LA000100		Cover	오일탱크커버	1	
M-8	DSC-BF005400		Screw	나사	3	
M-9	DPK-BB000200		O Ring	O-링	1	
M-10	CLB-JP000200		Joint	오일호스조인트	2	
M-11	DSC-BF005300		Joint Screw	조인트 나사	2	
M-12	CLB-BG001800		Clamp	오일 호스잡이(중)	2	
M-13	CLB-JG000800		Tube	오일호스	1	
M-14	CLB-JP000200		Joint	오일호스조인트	2	
M-15	DSC-BF005300		Joint Screw	조인트 나사	2	
M-16	CLB-BG001800		Clamp	오일 호스잡이(중)	2	
M-17	CLB-JG000800		TUBE	오일호스	1	
M-18	CLB-JP000200		Joint	오일호스조인트	1	
M-19	DSC-BF005300		Joint Screw	조인트 나사	1	
M-20	CLB-BG001800		Clamp	오일 호스잡이(중)	1	
M-21	CLB-JG000800		Tube	오일호스	1	
M-22	ALB-PS000300		Oil Distributor Assy	오일 분배기 (조)	1Set	
M-22-1	CLB-JH000100		Oil Distributor	오일 분배기	1	
M-22-2	PBR-AD000700		Plug	마개용 쇠구슬	2	
M-23	PSC-AC006200		Screw	나사	1	
M-24	DSC-BF005300		Joint Screw	조인트 나사	1	
M-25	CLB-JN000200		Oil Lever Gauge	오일게이지	1	
M-26	CST-JA000700		Oil Reservoir Assy	오일팬	1	
M-27	DSC-BJ001700		Screw	오일배출구나사	1	
M-28	CST-FB000100		Washer	오일배출구고무링	1	
M-29	PSC-AC006100		Screw	볼트(M5XP0.8, L=12)	4	
M-30	DWS-AA004600		Washer	와셔	4	
M-31	CST-FG000100		Rubber Ling	오일팬 고무링	1	
M-32	DGR-AG000100		Worm	웜	1	
M-33	DSC-CB000700		Screw	나사	1	
M-34	ALB-PS000400		Pipe Assy	급유파이프(조)	1Set	
M-34-1	CLB-JF000201		Pipe	급유파이프	1	Dec.02.10
M-34-2	DBR-AZ000100		Ball	파이프마개	1	
M-34-3	CLB-JD001700		Oil Wick	유심	1	
M-35	PSC-CB000200		Screw	무두나사(M4XP0.7,L=6)	1	
M-36	ALB-PS000500		Pipe Assy	오일파이프(조)	1	
M-36-1	CLB-JF000300		Pipe Assy	오일파이프	1	
M-36-2	CLB-JD001700		Oil Wick	유심(Φ2x260mm)	1	
M-36-3	DBR-AZ000100		Ball	파이프마개	2	
M-37	PSC-CB000200		Screw	무두나사(M4XP0.7,L=4)	1	

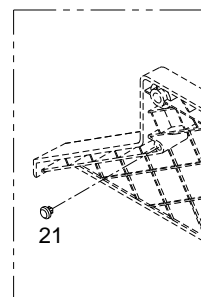
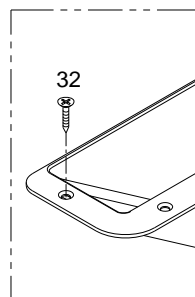
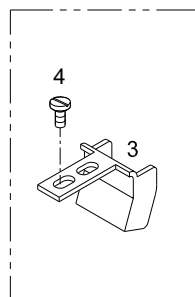
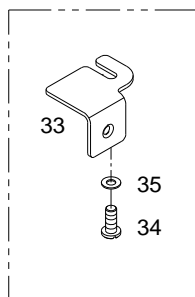
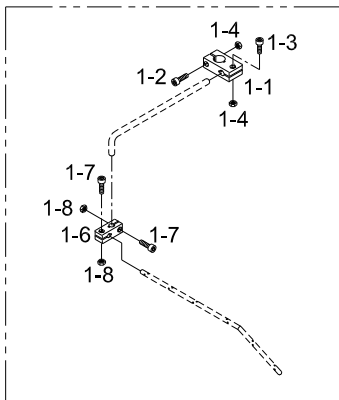
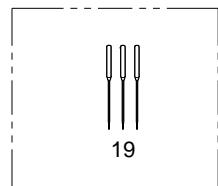
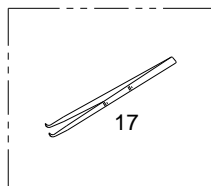
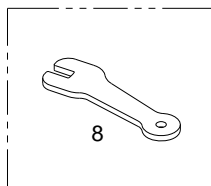
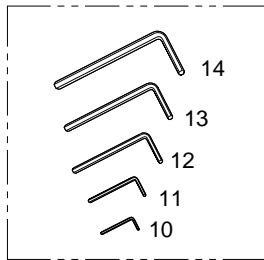
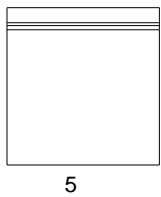
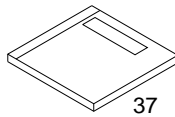
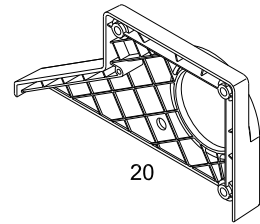
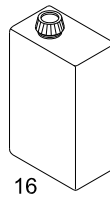
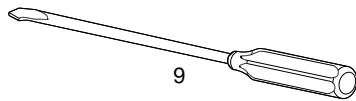
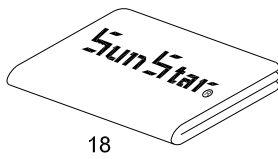
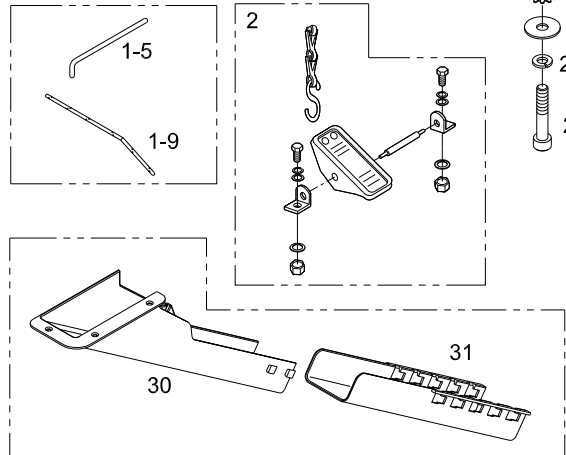
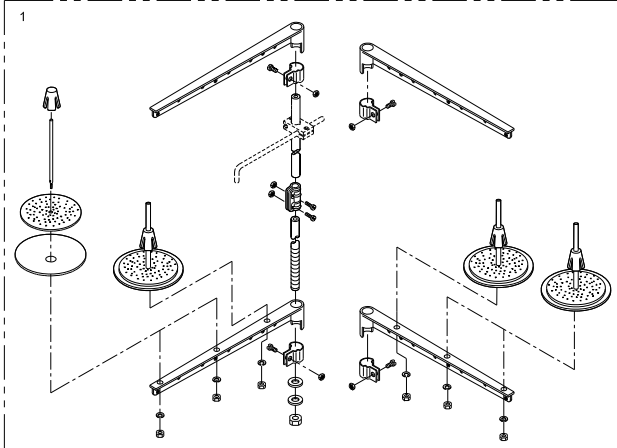
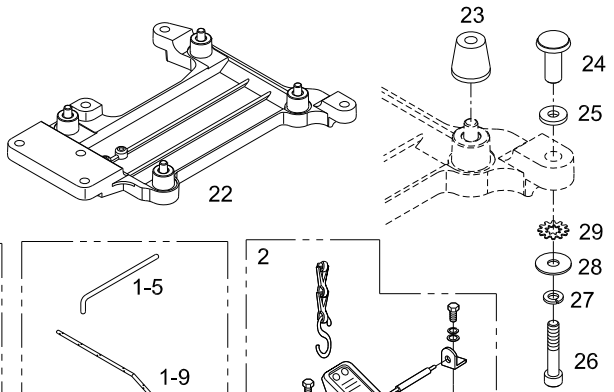
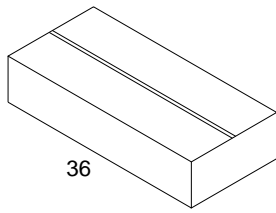

01

Exclusive Parts for SC 9204-01/223-4 Mechanism

전용부품 관계 SC 9204-01/223-4

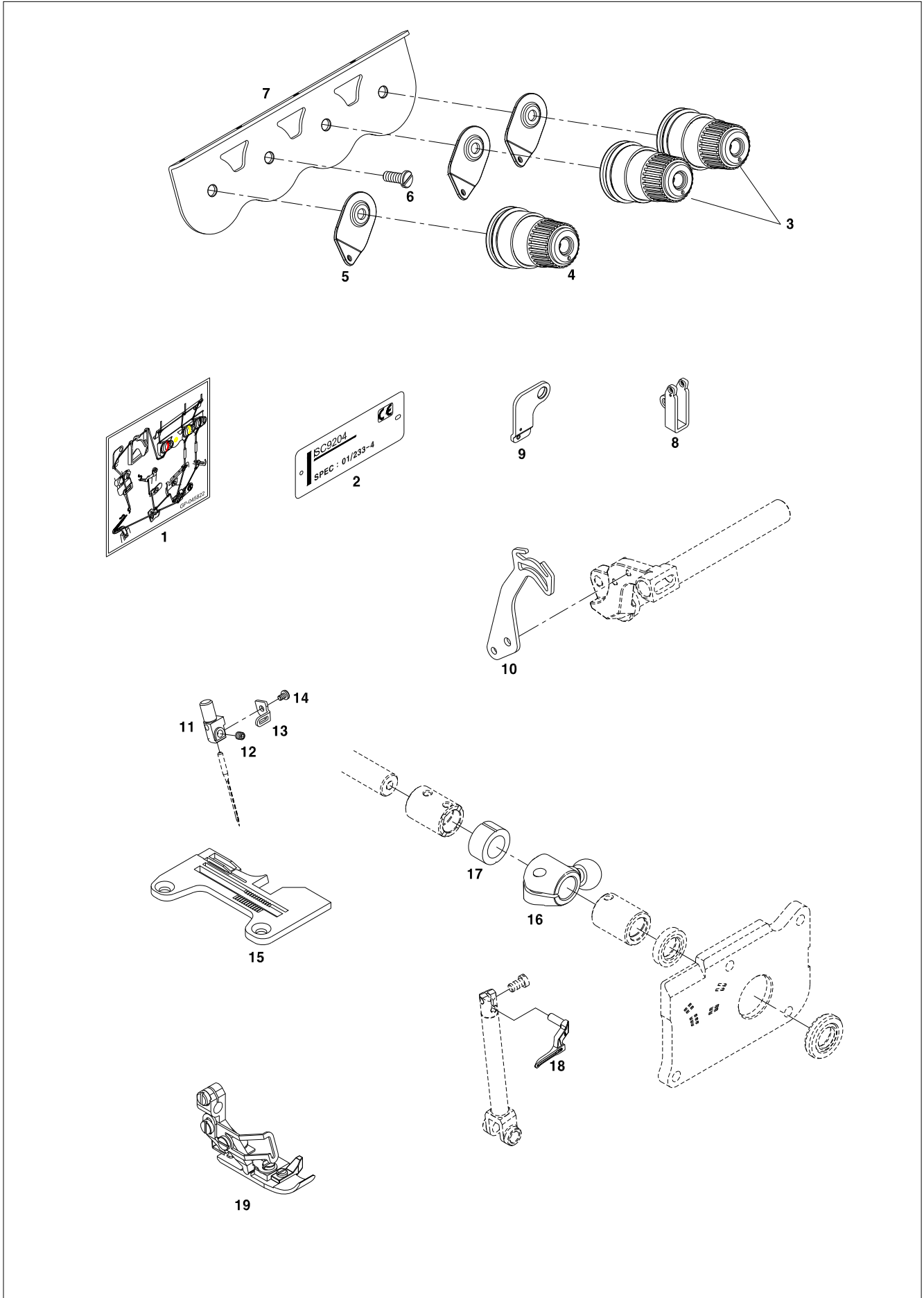

02

Exclusive Parts for SC 9204-02H/223-3 Mechanism

전용부품 관계 SC 9204-02H/223-3

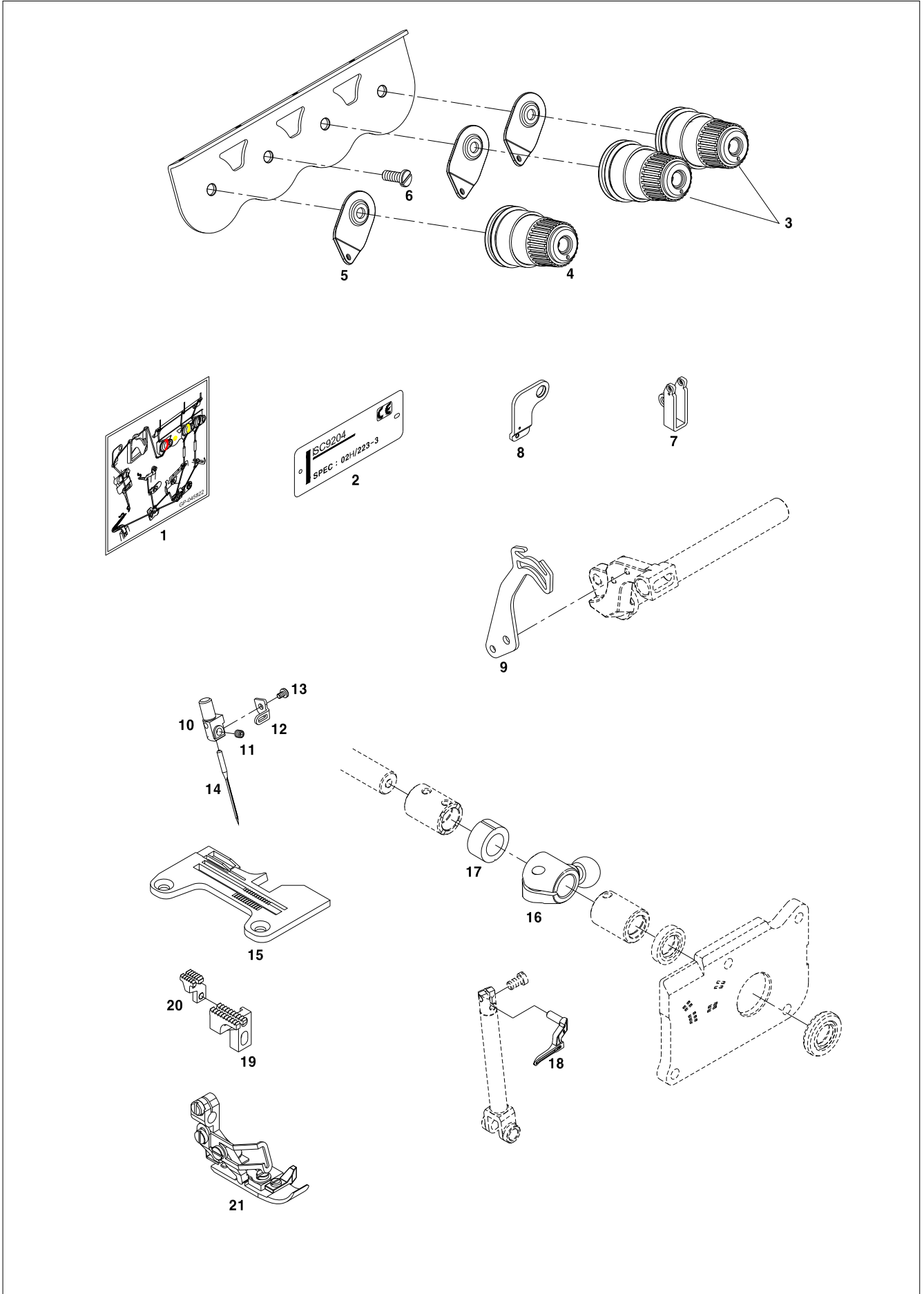

03

Exclusive Parts for SC 9214-03/333-2X3 Mechanism

전용부품 관계 SC 9214-03/333-2X3

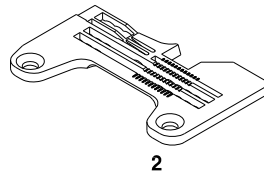
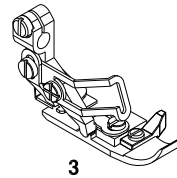
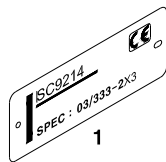

04

Exclusive Parts for SC 9212-02/333-2X5 Mechanism

전용부품 관계 SC 9212-02/333-2X5

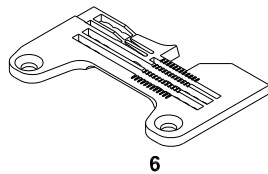
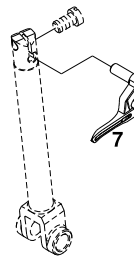
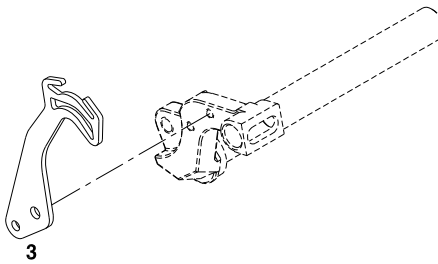
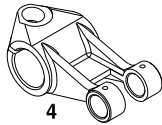
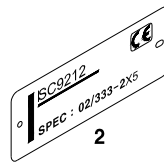
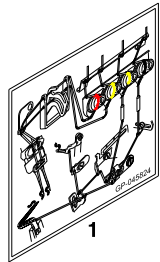

05

Exclusive Parts for SC 9316-03/233-3X5 Mechanism

전용부품 관계 SC 9316-03/233-3X5

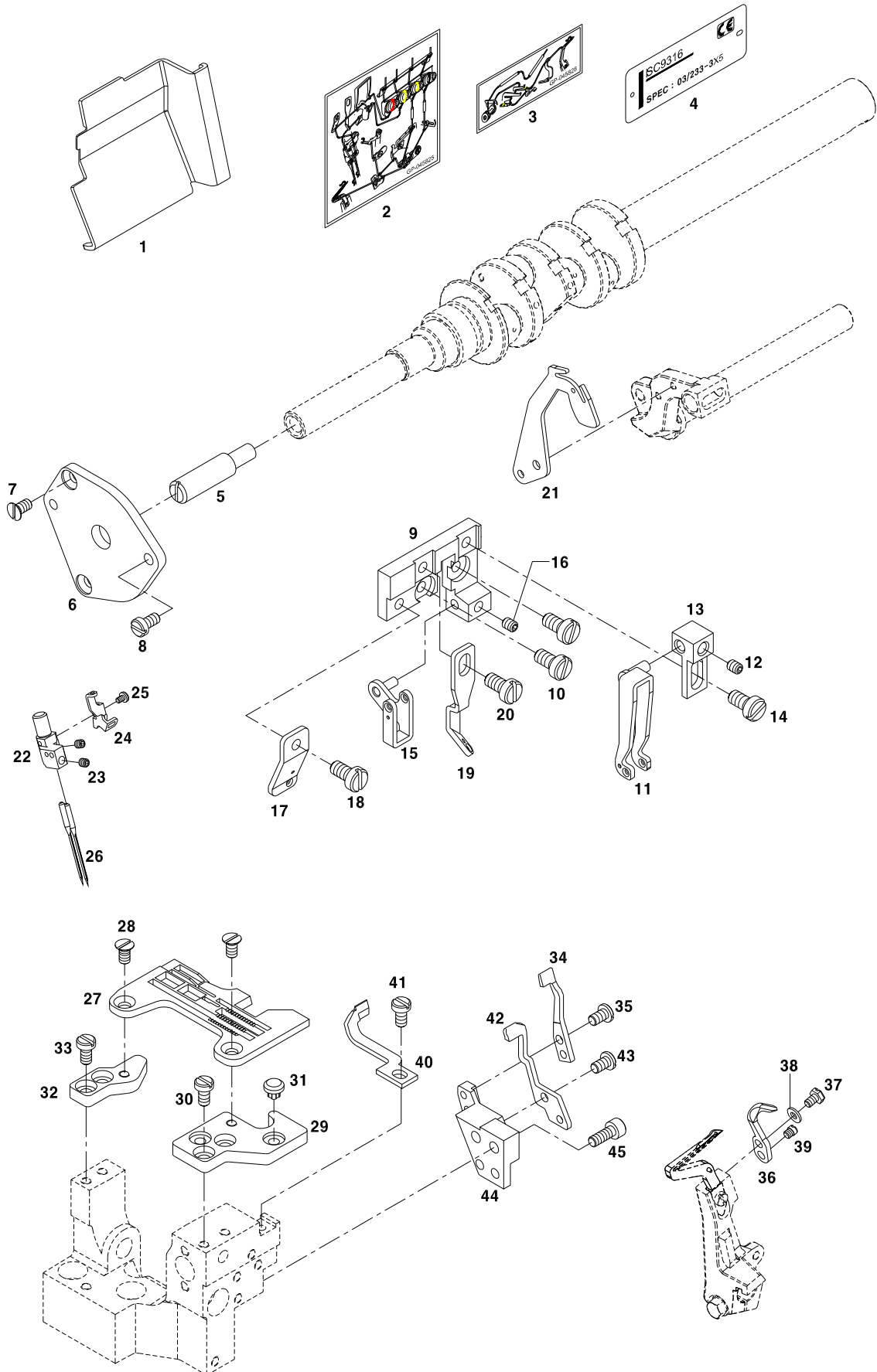

Ref. No.	Parts No.	Note	Name of Parts	품 명	Q'ty	Applied Period
O5-1	GP-044671-00		Front Cover (Left)	전면커버 (좌)	1	
O5-2	CMB-LD004500		Threading diagram 1	실길 안내 스티커	1	
O5-3	CMB-LD004600		Threading diagram 2	실길 안내 스티커	1	
O5-4	GP-045213-00		Model Mark	모델 마크	1	
O5-5	DPN-BC004400		Pin	주축 핀 전	1	
O5-6	CCS-BJ000200		Cover	주축 커버 전	1	
O5-7	13009SC-4113		Screw	나사	2	
O5-8	SC-000850-00		Screw	나사	1	
O5-9	CTG-BK000100		Thread Guide Bracket-Needle	실안내브라켓(바늘실)	1	
O5-10	DSC-BF005400		Screw(M4xL8)	나사(M4xL8)	2	
O5-11	ATG-PS000200		Thread Guide Ass'y	실안내(조)	1Set	
O5-12	PSC-CB000200		Screw(M4xL4)	나사(M4xL4)	1	
O5-13	CTG-BB000300		Thread Guide Holder	브라켓	1	
O5-14	DSC-BJ001900		Screw(M4xL5)	나사(M4xL5)	1	
O5-15	ATG-PS000300		Thread Guide Ass'y	실안내(조)	1Set	
O5-16	PSC-CB000200		Screw(M4xL4)	나사(M4xL4)	1	
O5-17	CTG-BJ000300		Thread Guide	실안내	1	
O5-18	DSC-BJ001900		Screw(M4xL5)	나사(M4xL5)	1	
O5-19	CTG-BJ000400		Thread Guide	실안내	1	
O5-20	DSC-BJ001900		Screw(M4xL5)	나사(M4xL5)	1	
O5-21	CTH-BJ000100		Needle Thread Take Up	바늘 실채기	1	
O5-22	CGA-BF000400		Needle Holder Assy.	바늘 잡이	1	
O5-23	DSC-CB001400		Screw	나사	2	
O5-24	CNB-BJ001200		Thread Guide	바늘잡이 실안내	1	
O5-25	DSC-BB004200		Screw	나사	1	
O5-26	PTC-CA000100		Needle	바늘	2	
O5-27	G-NP-0008		Needle Plate	침판	1	
O5-28	09-081S-8670		Screw	나사	2	
O5-29	CNB-BJ000100		Bracket (Front)	침판 브라켓 전	1	
O5-30	DSC-BF005400		Screw	나사	2	
O5-31	CMB-FD000900		Cushion Rubber	쿠션 고무	2	
O5-32	CNB-BJ000200		Bracket (Rear)	침판 브라켓 후	1	
O5-33	DSC-BF005400		Screw	나사	2	
O5-34	CGA-BK000300		Needle Guard (Front)	니들 가드 전	1	
O5-35	PSC-AC006300		Screw	나사	2	
O5-36	CGA-HG000200		Needle Guard (Rear)	니들 가드 후	1	
O5-37	DSC-AA001900		Bolt	나사	1	
O5-38	WS-000538-00		Spring Washer	스프링 와셔	1	
O5-39	DSC-BF005900		Screw	나사	1	
O5-40	CGA-BK000200		Needle Guard (Front)	니들 가드 전	1	
O5-41	DSC-BF005400		Screw	나사	1	
O5-42	CGA-BK000100		Needle Guard (Rear)	니들 가드 후	1	
O5-43	PSC-AC006300		Screw	나사	2	
O5-44	CNB-BB000700		Bracket	니들가드 브라켓	1	
O5-45	DSC-BF015100		Screw	나사	2	
O5-46	CUL-CB000300		Crank	상루퍼축크랭크A	1	
O5-47	DCL-BB002600		Spacer	루퍼축스페이서A	1	
O5-48	CLL-CB000200		Crank	하루퍼축크랭크A	1	
O5-49	DSC-AC000200		Bolt	볼트 (M6*P0.75, L=12)	1	
O5-50	DSC-CB000700		Screw	무두나사(M5*P0.8,L=5)	1	
O5-51	CGA-GB002400		Main Feed Dog	주이송톱니	1	
O5-52	CGA-GB002900		Auxiliary Feed Dog	보조 톱니	1	
O5-53	CGA-GB002800		Differential Feed Dog	차동이송 톱니	1	
O5-54	CTT-CB000300		Crank	메스 구동축 크랭크	1	
O5-55	CCT-BL000200		Upper Knife Clamp	동메스 클램프	1	
O5-56	CCT-BB001800		Lower Knife Holder	고정 메스 홀더	1	
O5-57	AGA-PS002400		Presser Foot Assy.	노루발 (조)(SC9316-03/233-3X5)	1	

05

Exclusive Parts for SC 9316-03/233-3X5 Mechanism

전용부품 관계 SC 9316-03/233-3X5

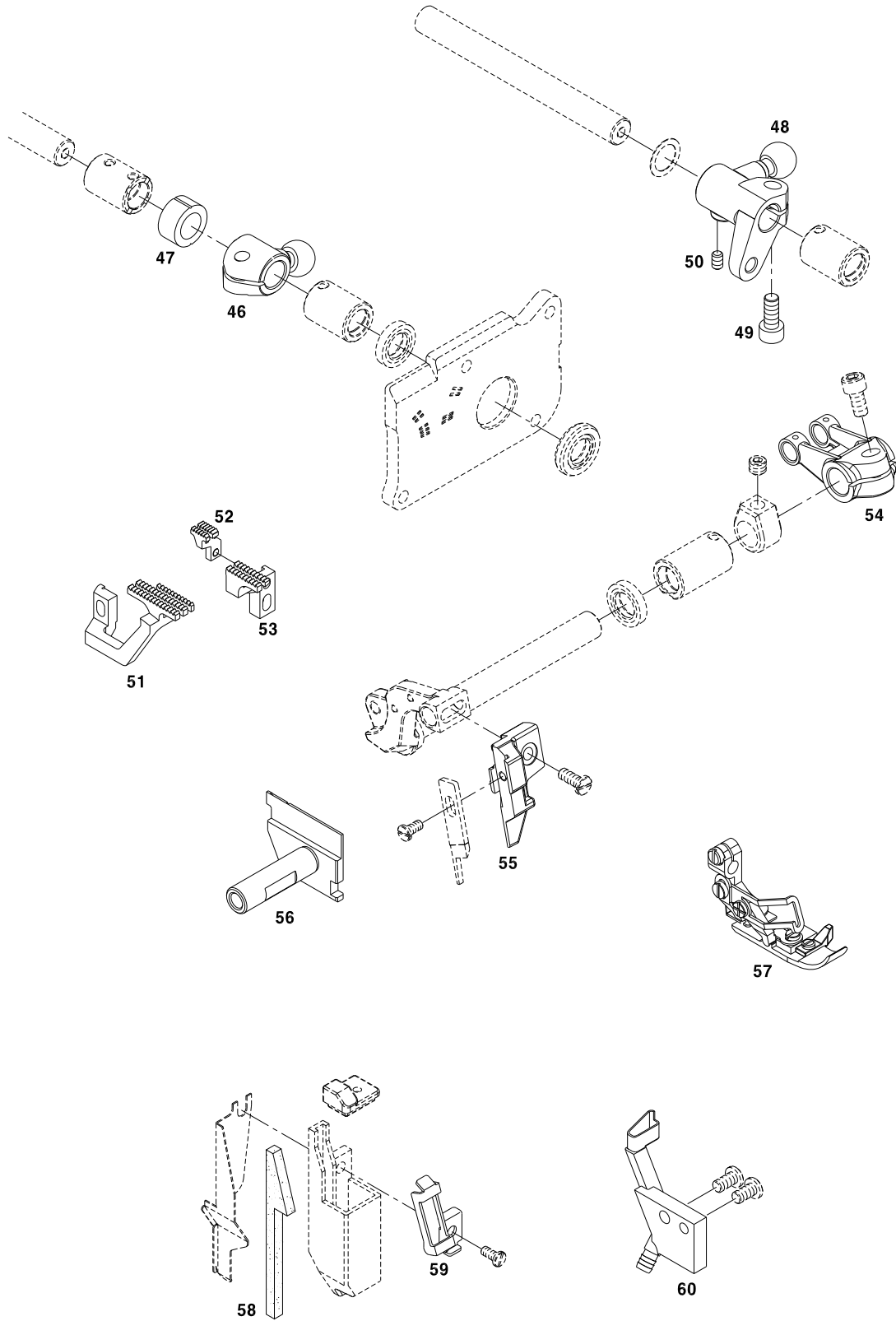

06

Exclusive Parts for SC 9316-03/333-5X5 Mechanism

전용부품 관계 SC 9316-03/333-5X5

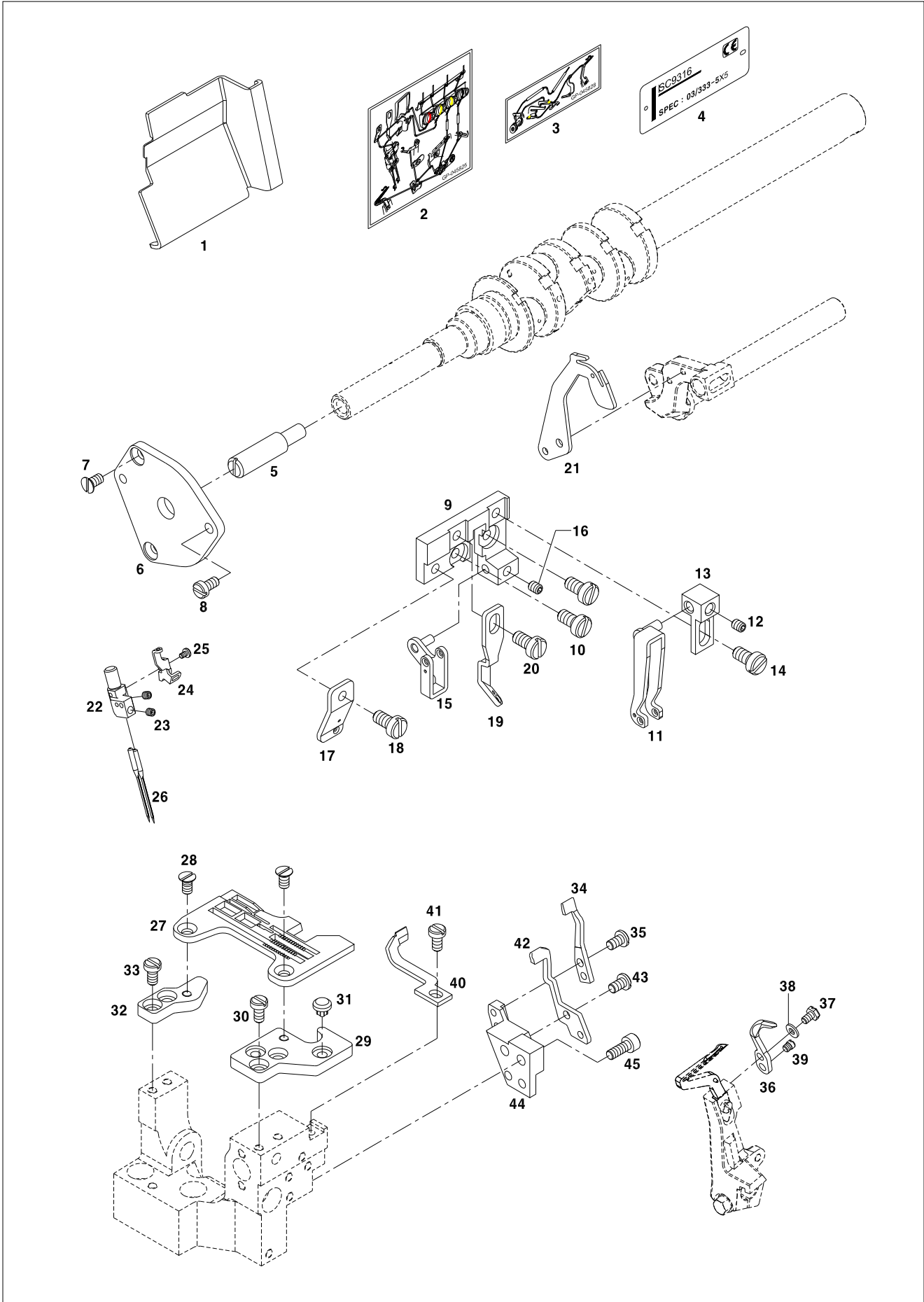

Ref. No.	Parts No.	Note	Name of Parts	품 명	Q'ty	Applied Period
O6-1	GP-044671-00		Front Cover (Left)	전면커버 (좌)	1	
O6-2	CMB-LD004500		Threading diagram 1	실길 안내 스티커	1	
O6-3	CMB-LD004600		Threading diagram 2	실길 안내 스티커	1	
O6-4	GP-045214-00		Model Mark	모델 마크	1	
O6-5	DPN-BC004400		Pin	주축 핀 전	1	
O6-6	CCS-BJ000200		Cover	주축 커버 전	1	
O6-7	13009SC-4113		Screw	나사	2	
O6-8	SC-000850-00		Screw	나사	1	
O6-9	CTG-BK000100		Thread Guide Bracket-Needle	실안내브라켓(바늘실)	1	
O6-10	DSC-BF005400		Screw(M4xL8)	나사(M4xL8)	2	
O6-11	ATG-PS000200		Thread Guide Ass'y	실안내(조)	1Set	
O6-12	PSC-CB000200		Screw(M4xL4)	나사(M4xL4)	1	
O6-13	CTG-BB000300		Thread Guide Holder	브라켓	1	
O6-14	DSC-BJ001900		Screw(M4xL5)	나사(M4xL5)	1	
O6-15	ATG-PS000300		Thread Guide Ass'y	실안내(조)	1Set	
O6-16	PSC-CB000200		Screw(M4xL4)	나사(M4xL4)	1	
O6-17	CTG-BJ000300		Thread Guide	실안내	1	
O6-18	DSC-BJ001900		Screw(M4xL5)	나사(M4xL5)	1	
O6-19	CTG-BJ000400		Thread Guide	실안내	1	
O6-20	DSC-BJ001900		Screw(M4xL5)	나사(M4xL5)	1	
O6-21	CTH-BJ000100		Needle Thread Take Up	바늘 실채기	1	
O6-22	CGA-BF000200		Needle Holder Assy.	바늘 잡이	1	
O6-23	DSC-CB001400		Screw	나사	2	
O6-24	CNB-BJ001200		Thread Guide	바늘잡이 실안내	1	
O6-25	DSC-BB004200		Screw	나사	1	
O6-26	PSC-CA000100		Needle	바늘	2	
O6-27	G-NP-0009		Needle Plate	침판	1	
O6-28	09-081S-8670		Screw	나사	2	
O6-29	CNB-BJ000100		Bracket (Front)	침판 브라켓 전	1	
O6-30	DSC-BF005400		Screw	나사	2	
O6-31	CMB-FD000900		Cushion Rubber	쿠션 고무	2	
O6-32	CNB-BJ000200		Bracket (Rear)	침판 브라켓 후	1	
O6-33	DSC-BF005400		Screw	나사	2	
O6-34	CGA-BK000300		Needle Guard (Front)	니들 가드 전	1	
O6-35	PSC-AC006300		Screw	나사	2	
O6-36	CGA-HG000200		Needle Guard (Rear)	니들 가드 후	1	
O6-37	DSC-AA001900		Bolt	나사	1	
O6-38	WS-000538-00		Spring Washer	스프링 와셔	1	
O6-39	DSC-BF005900		Screw	나사	1	
O6-40	CGA-BK000200		Needle Guard (Front)	니들 가드 전	1	
O6-41	DSC-BF005400		Screw	나사	1	
O6-42	CGA-BK000100		Needle Guard (Rear)	니들 가드 후	1	
O6-43	PSC-AC006300		Screw	나사	2	
O6-44	CNB-BB000700		Bracket	니들가드 브라켓	1	
O6-45	DSC-BF015100		Screw	나사	2	
O6-46	DCL-BB002600		Spacer	루퍼축스페이스A	1	
O6-47	CGA-BK000400		Upper Looper	상루퍼(#02)	1	
O6-48	CLL-CB000200		Crank	하루퍼축크랭크A	1	
O6-49	DSC-AC000200		Bolt	볼트 (M6*P0.75, L=12)	1	
O6-50	DSC-CB000700		Screw	무두나사(M5*P0.8,L=5)	1	
O6-51	CGA-GB002400		Main Feed Dog	주이송톱니	1	
O6-52	CGA-GB002500		Differential Feed Dog	차동이송 톱니	1	
O6-53	CCT-CB000300		Crank	메스 구동축 크랭크	1	
O6-54	CCT-BL000200		Upper Knife Clamp	동메스 클램프	1	
O6-55	CCT-BB001800		Lower Knife Holder	고정 메스 홀더	1	
O6-56	AGA-PS002300		Presser Foot Assy.	노루발 (조)(SC9316-03/333-5X5)	1Set	
O6-57	CLB-JL011300		Felt	실리콘 오일 통 헬트	1	

06

Exclusive Parts for SC 9316-03/333-5X5 Mechanism

전용부품 관계 SC 9316-03/333-5X5

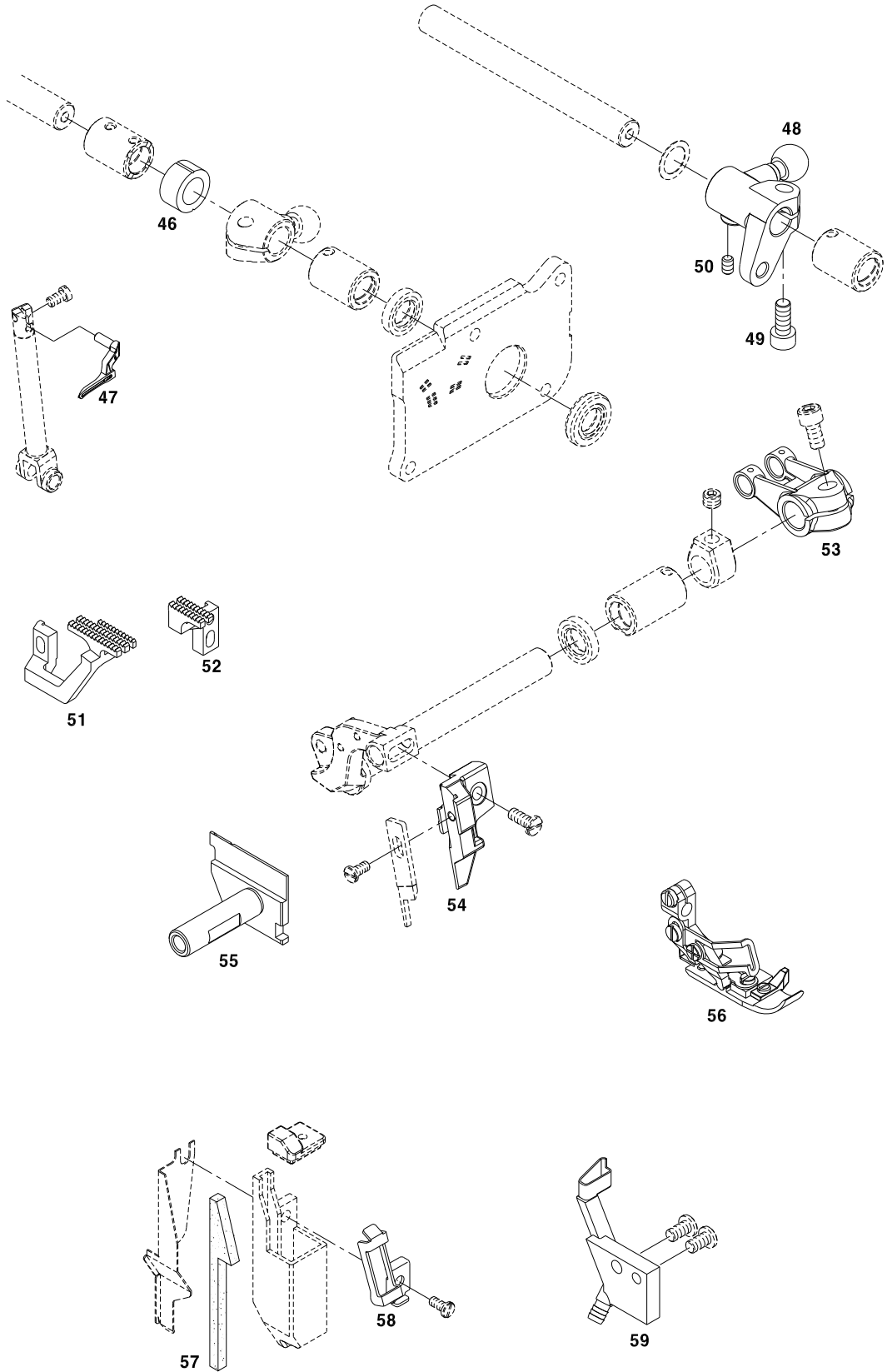

07

Exclusive Parts for SC 9344-A04/435-5X3X4 Mechanism

전용부품 관계 SC 9344-A04/435-5X3X4

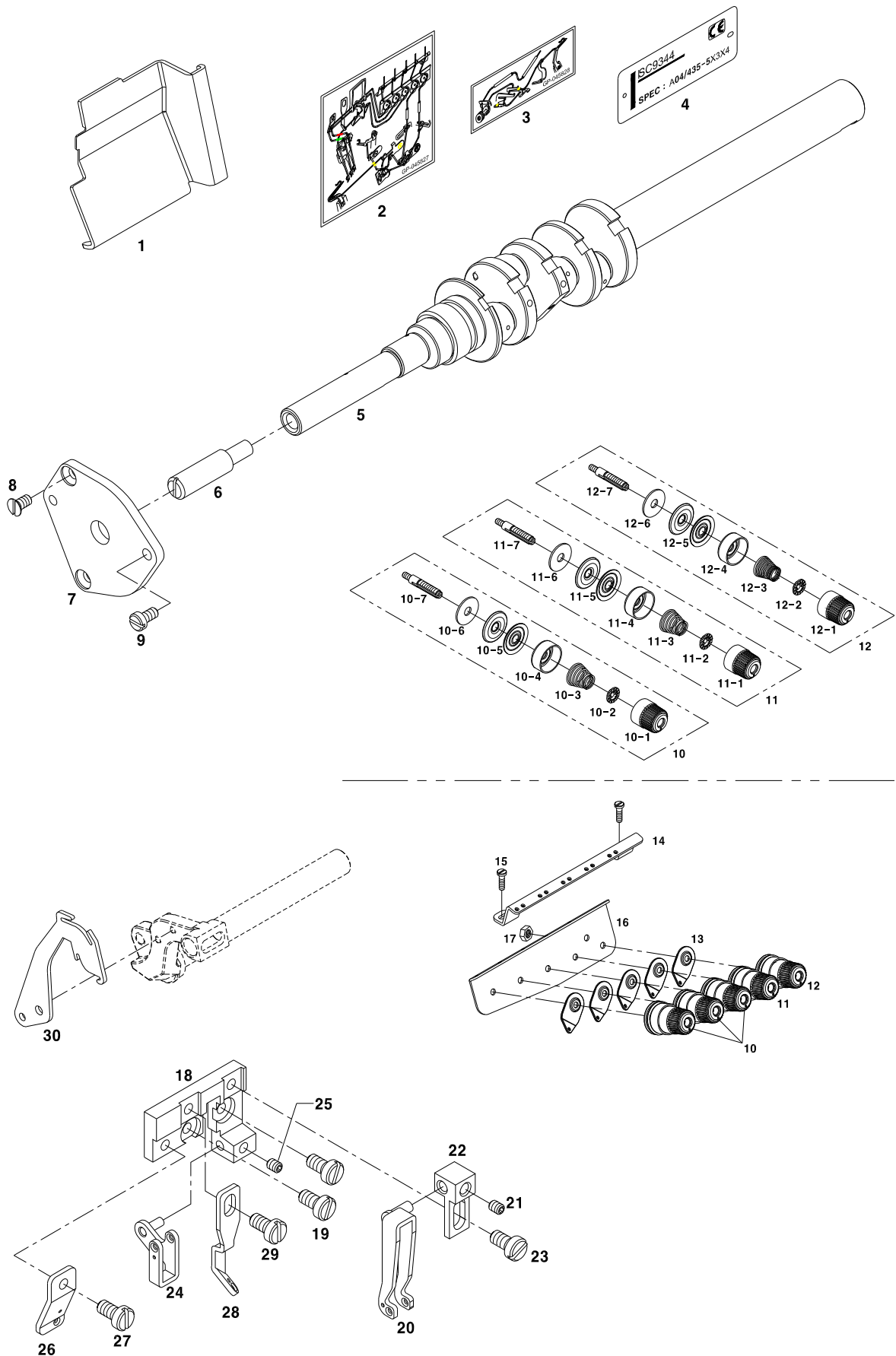

Ref. No.	Parts No.	Note	Name of Parts	품 명	Q'ty	Applied Period
07-1	GP-044671-00		Front Cover (Left)	전면커버 (좌)	1	
07-2	GP-045827-01		Threading Diagram 1	실길 안내 스티커	1	Oct.27.09
07-3	CMB-LD004600		Threading Diagram 2	실길 안내 스티커	1	
07-4	GP-045216-00		Model Mark	모델 마크	1	
07-5	ST-000122-00		Crank Shaft	주축	1	
07-6	DPN-BD004400		Pin	주축 핀 전	1	
07-7	CCS-BJ000200		Cover	주축 커버 전	1	
07-8	13009SC-4113		Screw	나사	2	
07-9	SC-000850-00		Screw	나사	1	
07-10	ATA-PS000900		Thread Tension Device Assy-Needle	실조절장치(조)-바늘실	3Set	
07-10-1	DSN-CD000300		Thread Tension Spring Cap Assy	실조절장치 캡(조)	1Set	
07-10-1-1	GP-001461-00		Thread Tension Spring Cap	실조절장치 캡	1	
07-10-1-2	GP-001462-00		Bushing for Thread Tension Spring Cap	실조절장치 캡 붓싱	1	
07-10-2	CTA-BN000300		Stopper for Tension Spring	실조절장치 스프링 스토퍼	1	
07-10-3	DSP-BA000500		Thread Tension Spring-Needle	실조절장치 스프링-바늘실	1	
07-10-4	CTA-BD000400		Retainer for Thread Tension Spring Cap	실조절장치 캡받침	1	
07-10-5	CTA-HL000200		Tension Disc	실조절장치 접시	2	
07-10-6	CTA-JL000100		Felt for Thread Tension Device	실조절장치 펠트	1	
07-10-7	CTA-HM000400		Thread Tension Post	실조절장치 포스트	1	
07-11	AS-015472-00		Thread Tension Device Assy-Needle	실조절장치(조)-루퍼실	1Set	
07-11-1	DSN-CD000300		Thread Tension Spring Cap Ass'y	실조절장치 캡(조)	1Set	
07-11-1-1	GP-001461-00		Thread Tension Spring Cap	실조절장치 캡	1	
07-11-1-2	GP-001462-00		Bushing for Thread Tension Spring Cap	실조절장치 캡 붓싱	1	
07-11-2	CTA-BN000300		Stopper for Tension Spring	실조절장치 스프링 스토퍼	1	
07-11-3	SP-000038-00		Thread Tension Spring-Needle	실조절장치 스프링-루퍼실	1	
07-11-4	CTA-BD000400		Retainer for Thread Tension Spring Cap	실조절장치 캡받침	1	
07-11-5	CTA-HL000200		Tension Disc	실조절장치 접시	2	
07-11-6	CTA-JL000100		Felt for Thread Tension Device	실조절장치 펠트	1	
07-11-7	CTA-HM000400		Thread Tension Post	실조절장치 포스트	1	
07-12	AS-015473-00		Thread Tension Device Assy-Looper	실조절장치(조)-루퍼실	1Set	
07-12-1	DSN-CD000300		Thread Tension Spring Cap Ass'y	실조절장치 캡(조)	1Set	
07-12-1-1	GP-001461-00		Thread Tension Spring Cap	실조절장치 캡	1	
07-12-1-2	GP-001462-00		Bushing for Thread Tension Spring Cap	실조절장치 캡 붓싱	1	
07-12-2	CTA-BN000300		Stopper for Tension Spring	실조절장치 스프링 스토퍼	1	
07-12-3	SP-000039-00		Thread Tension Spring-Looper	실조절장치 스프링-루퍼실	1	
07-12-4	CTA-BD000400		Retainer for Thread Tension Spring Cap	실조절장치 캡받침	1	
07-12-5	CTA-HL000200		Tension Disc	실조절장치 접시	2	
07-12-6	CTA-JL000100		Felt for Thread Tension Device	실조절장치 펠트	1	
07-12-7	CTA-HM000400		Thread Tension Post	실조절장치 포스트	1	
07-13	CTA-HK000100		Tension Guide	텐션 가이드	5	
07-14	GP-045225-00		Thread Guide	실안내	1	
07-15	DSC-BF005400		Screw(M4xL6)	나사(M4xL6)	2	
07-16	GP-045226-00		Thread Guide	실조절장치(조) 브라켓	1	
07-17	DSN-CD000600		Nut(11/64" n=40)	너트(11/64" n=40)	1	
07-18	CTG-BK000100		Thread Guide Bracket-Needle	실안내브라켓(바늘실)	1	
07-19	DSC-BF005400		Screw (M4xL8)	나사(M4xL8)	2	
07-20	AS-015471-00		Thread Guide Ass'y	실안내(조)	1Set	
07-21	PSC-CB000200		Screw(M4xL4)	나사(M4xL4)	1	
07-22	CTG-BB000300		Thread Guide Holder	브라켓	1	
07-23	DSC-BJ001900		Screw(M4xL5)	나사(M4xL5)	1	
07-24	ATG-PS000300		Thread Guide Ass'y	실안내(조)	1Set	
07-25	PSC-CB000200		Screw(M4xL4)	나사(M4xL4)	1	
07-26	GP-045228-00		Thread Guide	실안내	1	
07-27	DSC-BJ001900		Screw(M4xL5)	나사(M4xL5)	1	
07-28	CTG-BJ000400		Thread Guide	실안내	1	
07-29	DSC-BJ001900		Screw(M4xL5)	나사(M4xL5)	1	
07-30	GP-045234-00		Needle Thread Take Up	바늘 실채기	1	

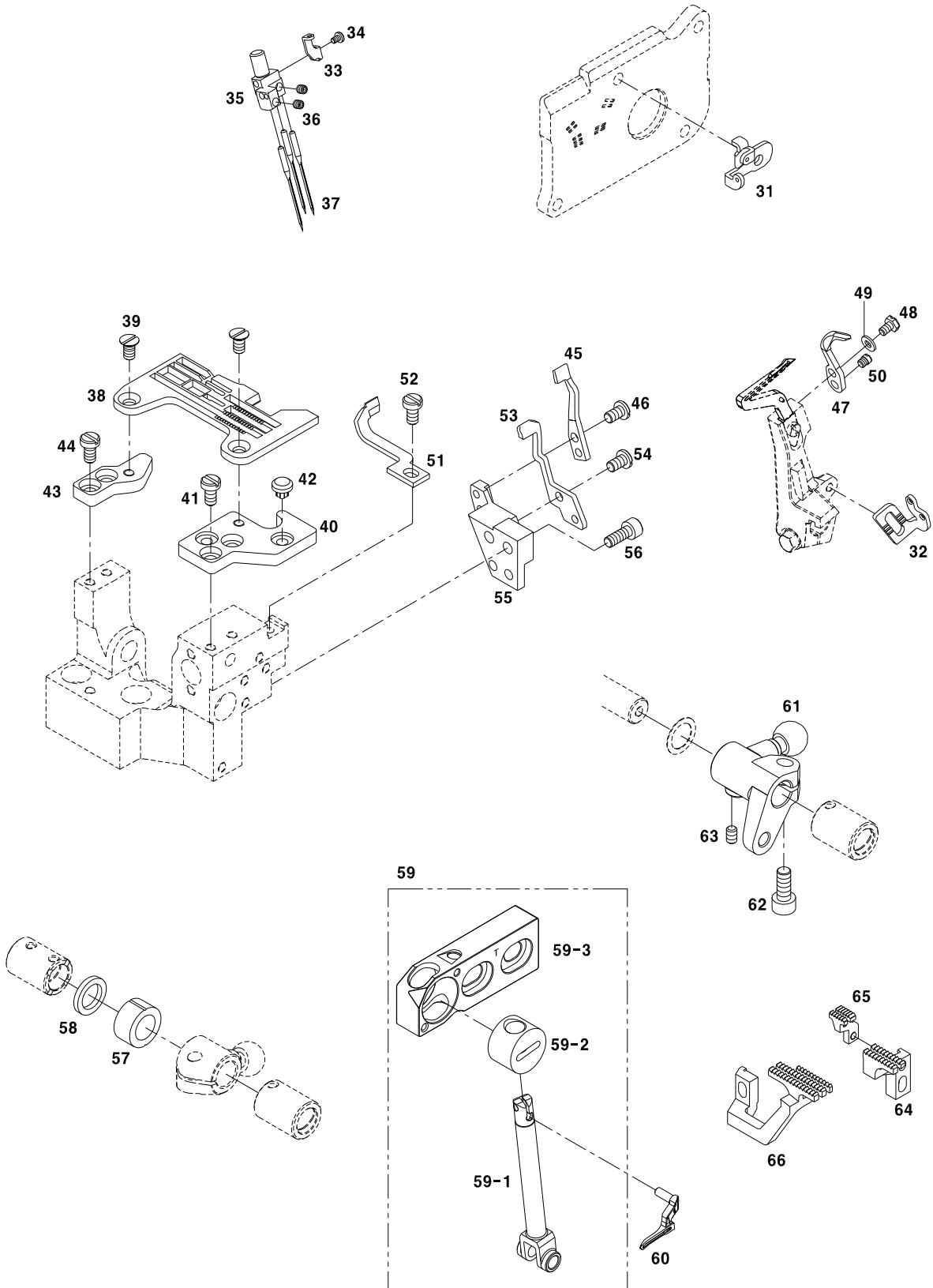



Ref. No.	Parts No.	Note	Name of Parts	품 명	Q'ty	Applied Period
07-31	GP-045233-00		Thread Guide	실안내	1	
07-32	GP-044859-00		Looper Thread Take Up	루퍼 실채기	1	
07-33	GP-046166-00		Thread Guide	비늘잡이 실안내	1	
07-34	SC-001721-00		Screw	나사	1	
07-35	GP-046039-00		Needle Holder Assy.	비늘 잡이	1	
07-36	DSC-CB001400		Screw	나사	3	
07-37	GP-046202-00		Needle	비늘	3	
07-38	G-NP-0011		Needle Plate	침판	1	
07-39	09-081S-8670		Screw	나사	2	
07-40	CNB-BJ000100		Bracket (Front)	침판 브라켓 前	1	
07-41	DSC-BF005400		Screw	나사	2	
07-42	CMB-FD000900		Cushion Rubber	쿠션 고무	2	
07-43	CNB-BJ000200		Bracket (Rear)	침판 브라켓 後	1	
07-44	DSC-BF005400		Screw	나사	2	
07-45	CGA-BK000300		Needle Guard (Front)	니들 가드 前	1	
07-46	PSC-AC006300		Screw	나사	2	
07-47	CGA-HG000200		Needle Guard (Rear)	니들 가드 後	1	
07-48	DSC-AA001900		Bolt	나사	1	
07-49	WS-000538-00		Spring Washer	스프링 와셔	1	
07-50	DSC-BF005900		Screw	나사	1	
07-51	CGA-BK000200		Needle Guard (Front)	니들 가드 前	1	
07-52	DSC-BF005400		Screw	나사	1	
07-53	CGA-BK000100		Needle Guard (Rear)	니들 가드 後	1	
07-54	PSC-AC006300		Screw	나사	2	
07-55	CNB-BB000700		Bracket	니들가드 브라켓	1	
07-56	DSC-BF015100		Screw	나사	2	
07-57	DCL-BB002600		Spacer	루퍼축스페이서A	1	
07-58	WS-000571-00		Washer	와셔(Φ10*Φ14.6,t=2)	1	
07-59	AS-016067-00		Upper Looper Holder Assy.	상루퍼잡이(T) (조)	1Set	
07-59-1	CUL-BF000100		Upper Looper Holder	상루퍼잡이	1	
07-59-2	CUL-BK000100		Upper Looper Holder Block	상루퍼잡이블럭	1	
07-59-3	GP-045184-00		Upper Looper Holder Base	상루퍼잡이베이스(T)	1	
07-60	GP-045830-00		Upper Looper	상루퍼(#03)	1	
07-61	CLL-CB000200		Crank	하루퍼축크랭크A	1	
07-62	DSC-AC000200		Bolt	M6*P0.75, L=12	1	
07-63	DSC-AC000200		Screw	무두나사(M5*P0.8,L=5)	1	
07-64	DSC-CB000700		Main Feed Dog	주이송톱니	1	
07-65	CGA-GB018600		Auxiliary Feed Dog	보조 톱니	1	
07-66	CGA-GB018700		Differential Feed Dog	차동이송 톱니	1	
07-67	CCT-CB000300		Crank	메스 구동축 크랭크	1	
07-68	CCT-BL000200		Upper Knife Clamp	동메스 클램프	1	
07-69	GP-046179-00		Flat Knife	동메스 (평형)	1	
07-70	PSC-AC005000		Screw	나사(M4xL22)	1	
07-71	CCT-BF001201		Lower Knife Holder	고정 메스 홀더	1	Feb.25.11
07-72	GP-045235-00		Lower Knife	고정메스	1	
07-73	AS-015740-00		Presser Foot Assy.	노루발(조)SC9344-A04/435-5X3X4	1	
07-74	ST-000085-00		Shaft	노루발 축	1	
07-75	GP-045520-00		Collar	누름대 올림 크랭크	1	
07-76	10-026S-9677		Bolt	나사(M5XP0.8 L=12)	1	
07-77	WS-000563-00		Washer	누름대 올림 크랭크 와셔	1	
07-78	PSR-AC000900		Retaining Ring	E-링	1	
07-79	GP-045521-00		Shaft	노루발 몸체 잡이	1	
07-80	GP-045527-00		Lever	노루발 올림 브라켓	1	
07-81	CPB-BB000200		PRESSER ARM	누름대 몸체	1	
07-82	CLB-JL011300		FELT	실리콘 오일 통 헬트	1	
07-83	CTG-BJ000500		THREAD GUIDE	실리콘 오일 통 실안내	1	
07-84	CMB-JB000700		SILICONE OIL RESERVOIR(LOWER)	윗 실 주유기	1	

07

Exclusive Parts for SC 9344-A04/435-5X3X4 Mechanism

전용부품 관계 SC 9344-A04/435-5X3X4

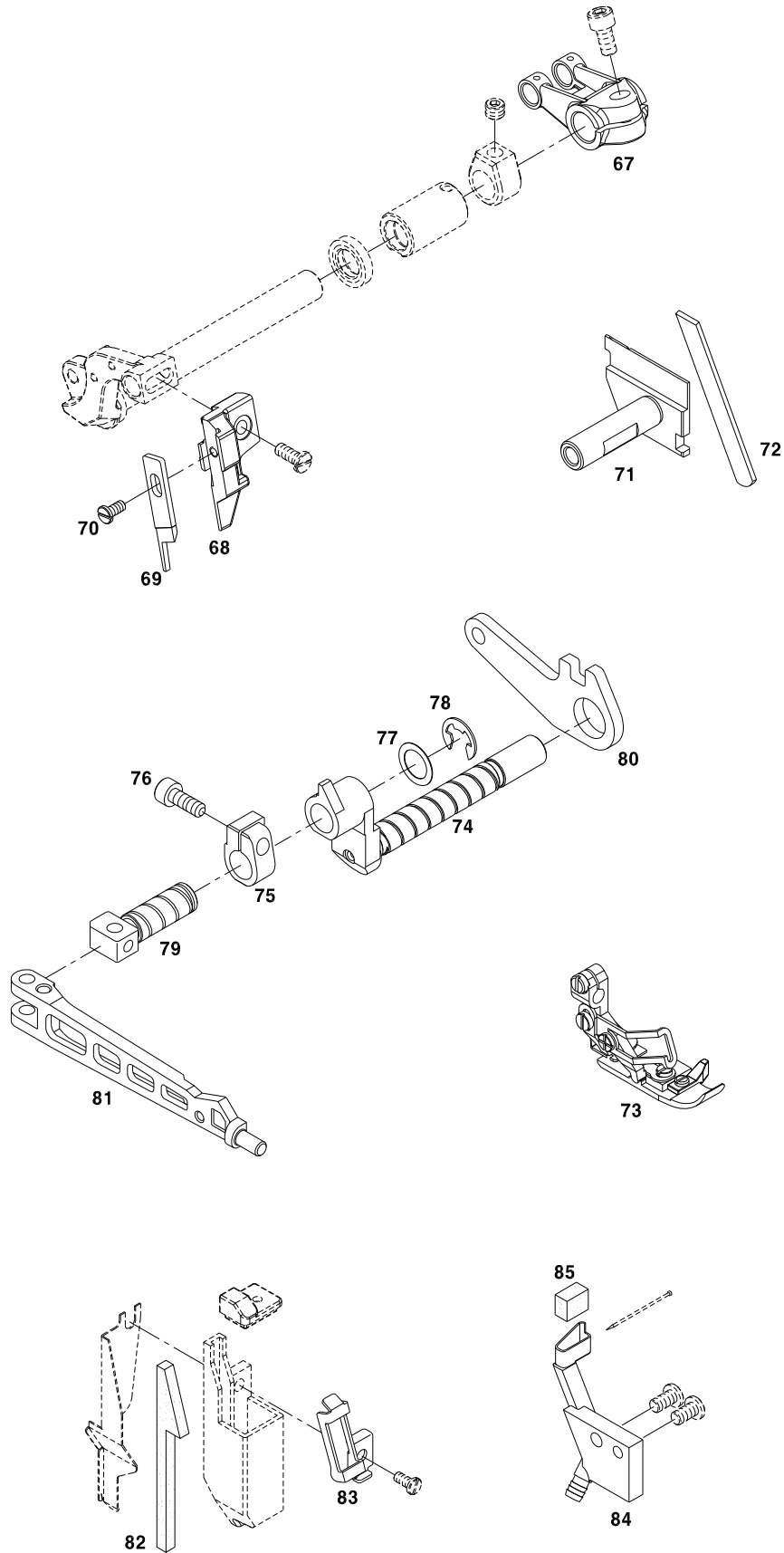

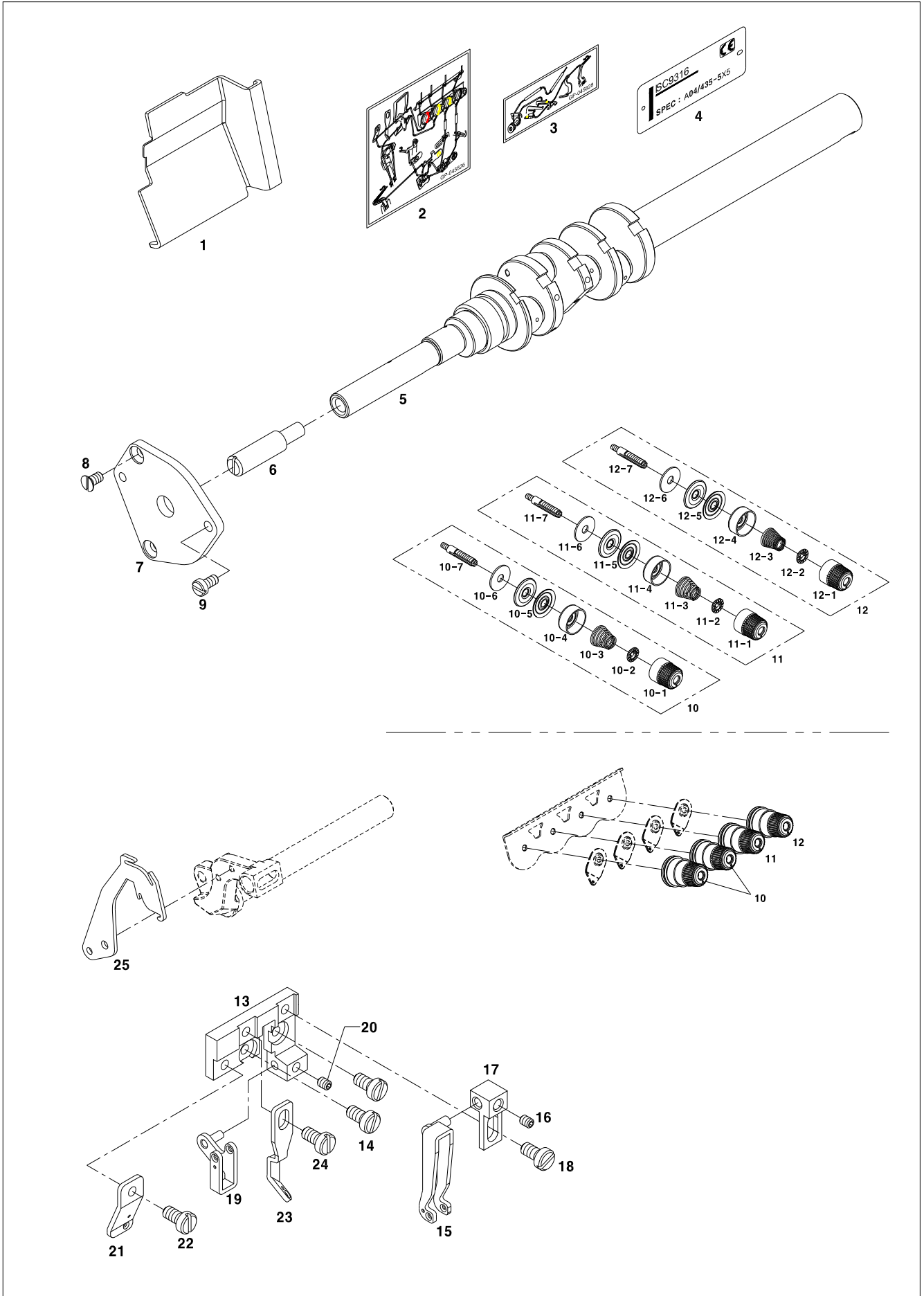

Ref. No.	Parts No.	Note	Name of Parts	품 명	Q'ty	Applied Period
08-1	GP-044671-00		Front Cover (Left)	전면커버 (좌)	1	
08-2	GP-045826-01		Threading Diagram 1	실길 안내 스티커	1	Oct.27.09
08-3	CMB-LD004600		Threading Diagram 2	실길 안내 스티커	1	
08-4	GP-045217-00		Model Mark	모델 마크	1	
08-5	ST-000122-00		Crank Shaft	주축	1	
08-6	DPN-BC004400		Pin	주축 핀 전	1	
08-7	CCS-BJ000200		Cover	주축 커버 전	1	
08-8	13009SC-4113		Screw	나사	2	
08-9	SC-000850-00		Screw	나사	1	
08-10	ATA-PS000900		Thread Tension Device Assy-Needle	실조절장치(조)-바늘실	2Set	
08-10-1	DSN-CD000300		Thread Tension Spring Cap ASS'Y	실조절장치 캡(조)	1Set	
08-10-1-1	GP-001461-00		Thread Tension Spring Cap	실조절장치 캡	1	
08-10-1-2	GP-001462-00		Bushing for Thread Tension Spring Cap	실조절장치 캡 붓심	1	
08-10-2	CTA-BN000300		Stopper for Tension Spring	실조절장치 스프링 스토퍼	1	
08-10-3	SP-000019-00		Thread Tension Spring-Needle	실조절장치 스프링-바늘실	1	
08-10-4	CTA-BD000400		Retainer for Thread Tension Spring Cap	실조절장치 캡받침	1	
08-10-5	CTA-HL000200		Tension Disc	실조절장치 접시	2	
08-10-6	CTA-JL000100		Felt for Thread Tension Device	실조절장치 펠트	1	
08-10-7	CTA-HM000400		Thread Tension Post	실조절장치 포스트	1	
08-11	AS-015472-00		Thread Tension Device Assy-Needle	실조절장치(조)-루퍼실	1Set	
08-11-1	DSN-CD000300		Thread Tension Spring Cap Ass'y	실조절장치 캡(조)	1Set	
08-11-1-1	GP-001461-00		Thread Tension Spring CAP	실조절장치 캡	1	
08-11-1-2	GP-001462-00		Bushing for Thread Tension Spring Cap	실조절장치 캡 붓심	1	
08-11-2	CTA-BN000300		Stopper for Tension Spring	실조절장치 스프링 스토퍼	1	
08-11-3	CTA-BD000400		Thread Tension Spring-Needle	실조절장치 스프링-루퍼실	1	
08-11-4	CTA-HL000200		Retainer for Thread Tension Spring Cap	실조절장치 캡받침	1	
08-11-5	CTA-JL000100		Tension Disc	실조절장치 접시	2	
08-11-6	CTA-HM000400		Felt for Thread Tension Device	실조절장치 펠트	1	
08-11-7	GP-044834-00		Thread Tension Post	실조절장치 포스트	1	
08-12	AS-015473-00		Thread Tension Device Assy-Looper	실조절장치(조)-루퍼실	1Set	
08-12-1	DSN-CD000300		Thread Tension Spring Cap Ass'y	실조절장치 캡(조)	1Set	
08-12-1-1	GP-001461-00		Thread Tension Spring Cap	실조절장치 캡	1	
08-12-1-2	GP-001462-00		Bushing for Thread Tension Spring Cap	실조절장치 캡 붓심	1	
08-12-2	CTA-BN000300		Stopper for Tension Spring	실조절장치 스프링 스토퍼	1	
08-12-3	SP-000039-00		Thread Tension Spring-Looper	실조절장치 스프링-루퍼실	1	
08-12-4	CTA-BD000400		Retainer for Thread Tension Spring Cap	실조절장치 캡받침	1	
08-12-5	CTA-HL000200		Tension Disc	실조절장치 접시	2	
08-12-6	CTA-JL000100		Felt for Thread Tension Device	실조절장치 펠트	1	
08-12-7	CTA-HM000400		Thread Tension Post	실조절장치 포스트	1	
08-13	CTG-BK000100		Thread Guide Bracket-Needle	실안내브라켓(바늘실)	1	
08-14	DSC-BF005400		Screw(M4xL8)	나사(M4xL8)	2	
08-15	ATG-PS000200		Thread Guide Ass'y	실안내(조)	1Set	
08-16	PSC-CB000200		Screw(M4xL4)	나사(M4xL4)	1	
08-17	CTG-BB000300		Thread Guide Holder	브라켓	1	
08-18	DSC-BJ001900		Screw(M4xL5)	나사(M4xL5)	1	
08-19	ATG-PS000300		Thread Guide Ass'y	실안내(조)	1Set	
08-20	PSC-CB000200		Screw(M4xL4)	나사(M4xL4)	1	
08-21	CTG-BJ000300		Thread Guide	실안내	1	
08-22	DSC-BJ001900		Screw(M4xL5)	나사(M4xL5)	1	
08-23	CTG-BJ000400		Thread Guide	실안내	1	
08-24	DSC-BJ001900		Screw(M4xL5)	나사(M4xL5)	1	
08-25	GP-046552-00		Needle Thread Take Up	바늘 실채기	1	
08-26	GP-045233-00		Thread Guide	실안내	1	
08-27	GP-044859-00		Looper Thread Take Up	루퍼 실채기	1	
08-28	GP-046166-00		Thread Guide	바늘잡이 실안내	1	
08-29	DSC-BB004200		Screw	나사	1	
08-30	GP-046038-00		Needle Holder Assy.	바늘 잡이	1	

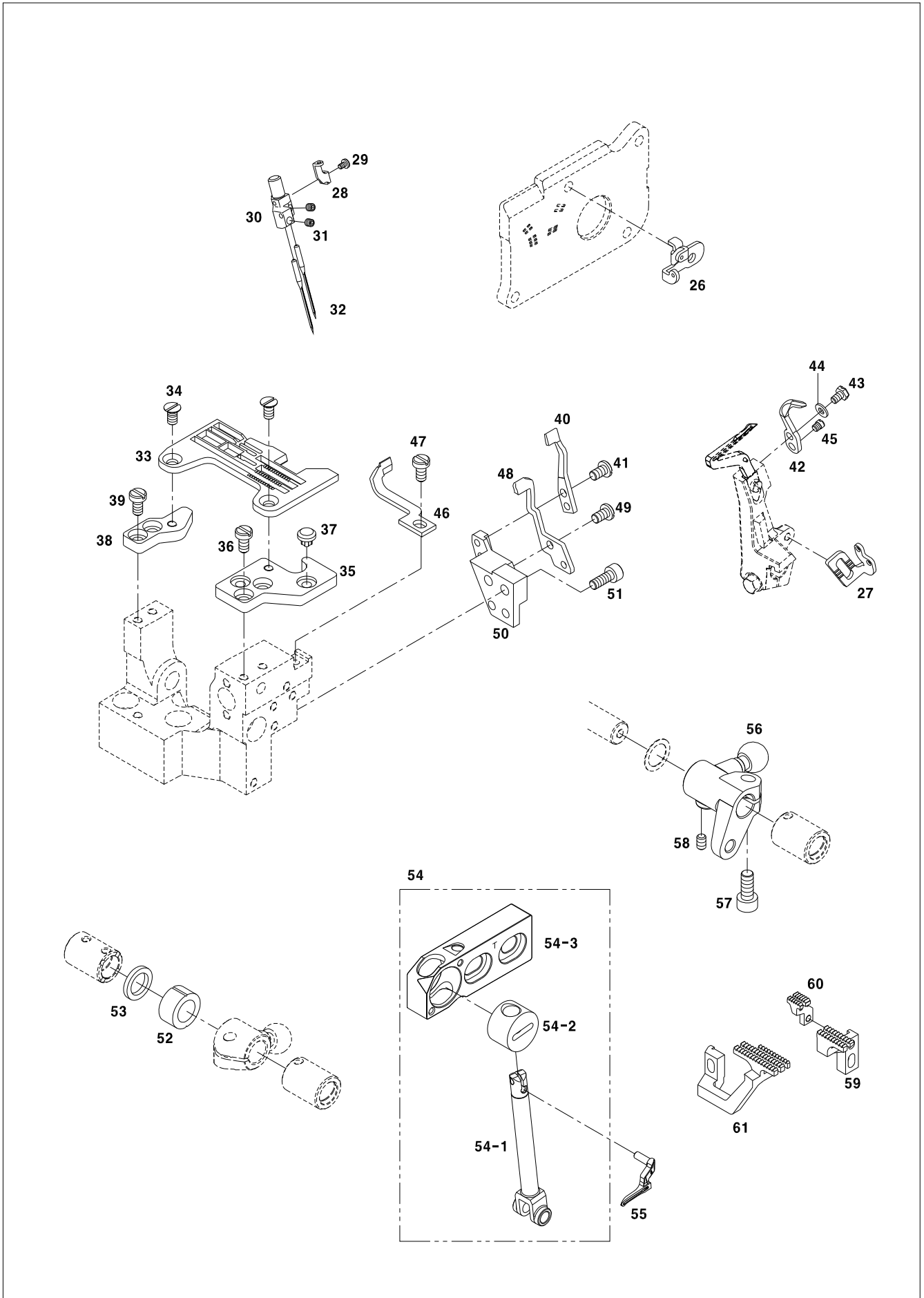

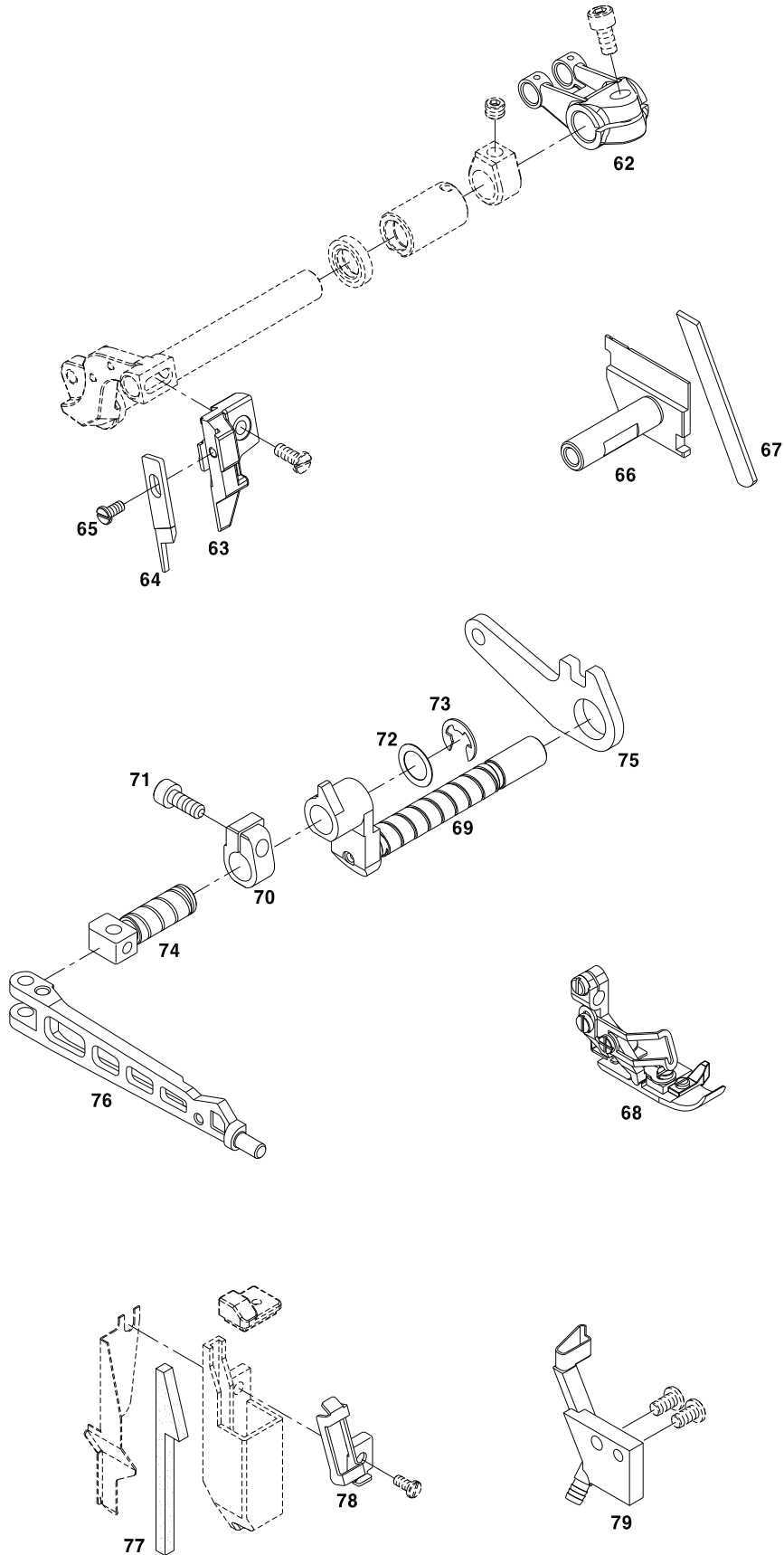

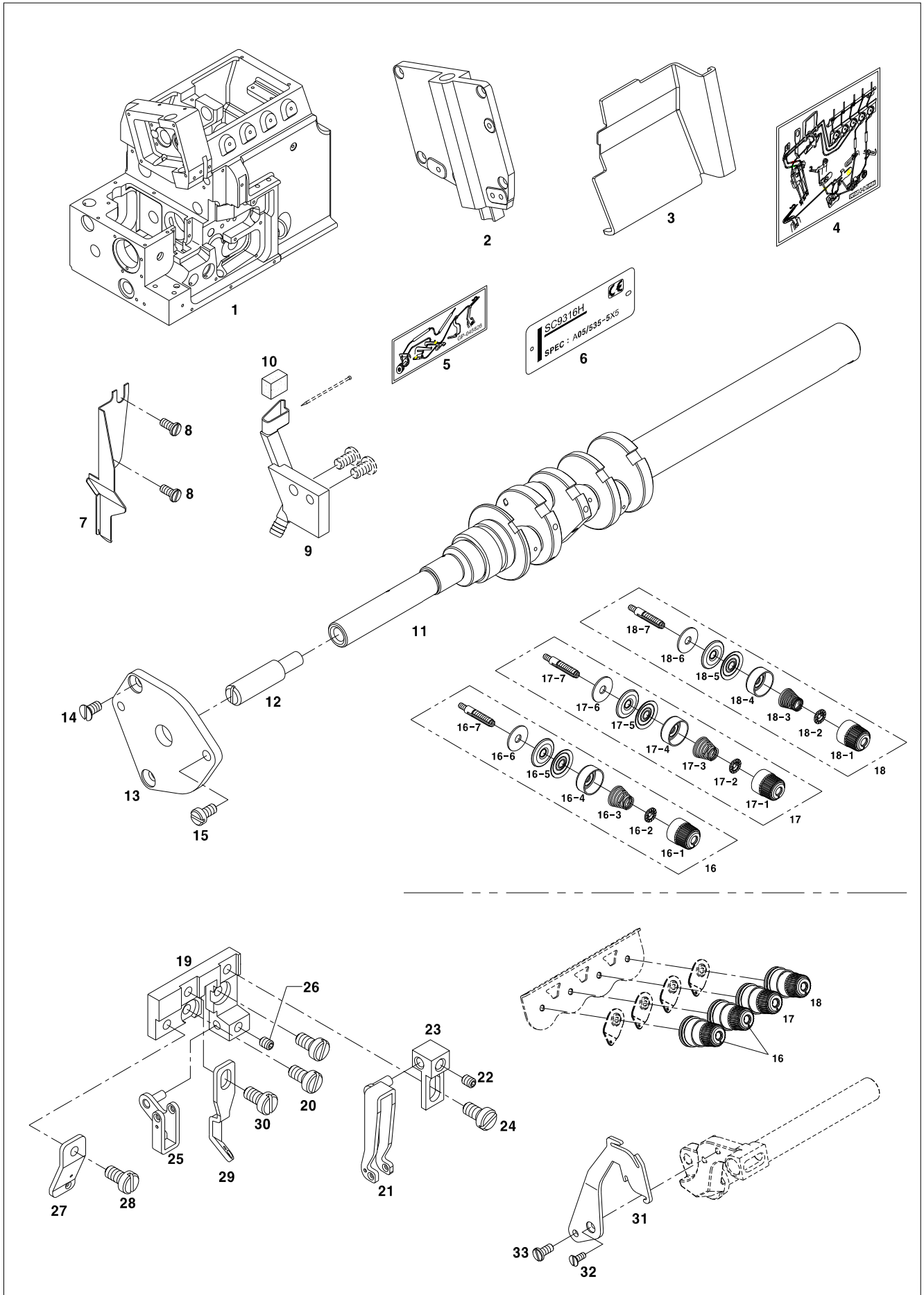

Ref. No.	Parts No.	Note	Name of Parts	품 명	Q'ty	Applied Period
09-1	GP-045283-02		Frame	프레임	1	
09-2	GP-045645-00		Face Cover	면판	1	
09-3	GP-044671-00		Front Cover (Left)	전면커버 (좌)	1	
09-4	GP-045827-01		Threading Diagram 1	실길 안내 스티커	1	Oct.27.09
09-5	CMB-LD004600		Threading Diagram 2	실길 안내 스티커	1	
09-6	GP-045215-00		Model Mark	모델 마크	1	
09-7	GP-045551-00		Cover	오일커버 A	1	
09-8	DSC-BJ001800		Screw	나사(M4XP0.7 L=10)	2	
09-9	CMB-JB000700		Silicone Oil Reservoir(Lower)	윌 실 주유기	1	
09-10	CMB-JL000300		Oil Felt	윌실주유기 펠트	1	
09-11	ST-000123-00		Crankshaft	주축	1	
09-12	DPN-BC004400		Pin	주축 핀 전	1	
09-13	CCS-BJ000200		Cover	주축 커버 전	1	
09-14	13009SC-4113		Screw	나사	2	
09-15	SC-000850-00		Screw	나사	1	
09-16	ATA-PS000900		Thread Tension Device Assembly-Needle	실조절장치(조)-바늘실	2Set	
09-16-1	DSN-CD000300		Thread Tension Spring Cap Ass'Y	실조절장치 캡(조)	1Set	
09-16-1-1	GP-001461-00		Thread Tension Spring Cap	실조절장치 캡	1	
09-16-1-2	GP-001462-00		Bushing For Thread Tension Spring Cap	실조절장치 캡 붓싱	1	
09-16-2	CTA-BN000300		Stopper For Tension Spring	실조절장치 스프링 스톱퍼	1	
09-16-3	DSP-BA000500		Thread Tension Spring-Needle	실조절장치 스프링-바늘실	1	
09-16-4	CTA-BD000400		Retainer For Thread Tension Spring Cap	실조절장치 캡받침	1	
09-16-5	CTA-HL000200		Tension Disc	실조절장치 접시	2	
09-16-6	CTA-JL000100		Felt For Thread Tension Device	실조절장치 펠트	1	
09-16-7	CTA-HM000400		Thread Tension Post	실조절장치 포스트	1	
09-17	AS-015472-00		Thread Tension Device Assembly-Needle	실조절장치(조)-루퍼실	1Set	
09-17-1	DSN-CD000300		Thread Tension Spring Cap Ass'Y	실조절장치 캡(조)	1Set	
09-17-1-1	GP-001461-00		Thread Tension Spring Cap	실조절장치 캡	1	
09-17-1-2	GP-001462-00		Bushing For Thread Tension Spring Cap	실조절장치 캡 붓싱	1	
09-17-2	CTA-BN000300		Stopper For Tension Spring	실조절장치 스프링 스톱퍼	1	
09-17-3	SP-000038-00		Thread Tension Spring-Needle	실조절장치 스프링-루퍼실	1	
09-17-4	CTA-BD000400		Retainer For Thread Tension Spring Cap	실조절장치 캡받침	1	
09-17-5	CTA-HL000200		Tension Disc	실조절장치 접시	2	
09-17-6	CTA-JL000100		Felt For Thread Tension Device	실조절장치 펠트	1	
09-17-7	CTA-HM000400		Thread Tension Post	실조절장치 포스트	1	
09-18	AS-015473-00		Thread Tension Device Assembly-Looper	실조절장치(조)-루퍼실	1Set	
09-18-1	DSN-CD000300		Thread Tension Spring Cap Ass'Y	실조절장치 캡(조)	1Set	
09-18-1-1	GP-001461-00		Thread Tension Spring Cap	실조절장치 캡	1	
09-18-1-2	GP-001462-00		Bushing For Thread Tension Spring Cap	실조절장치 캡 붓싱	1	
09-18-2	CTA-BN000300		Stopper For Tension Spring	실조절장치 스프링 스톱퍼	1	
09-18-3	SP-000039-00		Thread Tension Spring-Looper	실조절장치 스프링-루퍼실	1	
09-18-4	CTA-BD000400		Retainer For Thread Tension Spring Cap	실조절장치 캡받침	1	
09-18-5	CTA-HL000200		Tension Disc	실조절장치 접시	2	
09-18-6	CTA-JL000100		Felt For Thread Tension Device	실조절장치 펠트	1	
09-18-7	CTA-HM000400		Thread Tension Post	실조절장치 포스트	1	
09-19	CTG-BK000100		Thread Guide Bracket-Needle	실안내 브라켓(바늘실)	1	
09-20	DSC-BF005400		Screw(M4Xl8)	나사(M4xL8)	2	
09-21	ATG-PS000200		Thread Guide Ass'Y	실안내(조)	1Set	
09-21-1	CTG-BJ000100		Thread Guide	실안내	1	
09-21-2	DPN-BC000800		Pin	실안내 핀	1	
09-22	PSC-CB000200		Screw(M4Xl4)	나사(M4xL4)	1	
09-23	CTG-BB000300		Thread Guide Holder	브라켓	1	
09-24	DSC-BJ001900		Screw(M4Xl5)	나사(M4xL5)	1	
09-25	ATG-PS000300		Thread Guide Ass'Y	실안내(조)	1Set	
09-25-1	CTG-BJ000200		Thread Guide	실안내	1	
09-25-2	DPN-BC000800		Pin	실안내 핀	1	
09-26	PSC-CB000200		Screw(M4Xl4)	나사(M4xL4)	1	

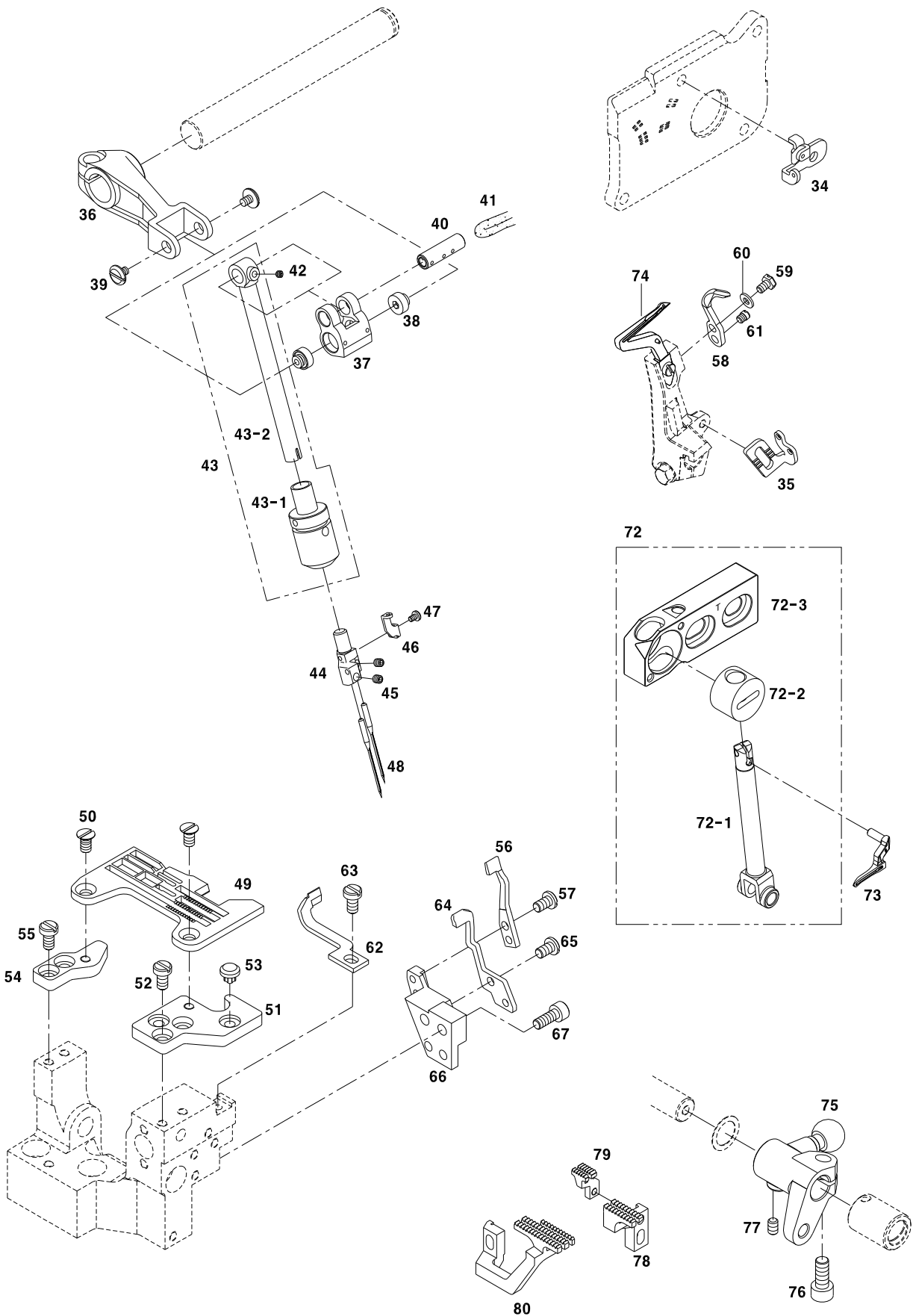

Ref. No.	Parts No.	Note	Name of Parts	품 명	Q'ty	Applied Period
09-27	GP-045229-00		Thread Guide	실안내	1	
09-28	DSC-BJ001900		Screw(M4X15)	나사(M4xL5)	1	
09-29	GP-045230-00		Thread Guide	실안내	1	
09-30	DSC-BJ001900		Screw(M4X15)	나사(M4xL5)	1	
09-31	GP-045231-00		Needle Thread Take Up	바늘 실채기	1	
09-32	DSC-BB001000		Screw(M3X6)	나사(M3x6)	1	
09-33	DSC-BF003900		Screw(M3X6)	나사(M3x6)	1	
09-34	GP-045233-00		Thread Guide	실안내	1	
09-35	GP-044859-00		Looper Thread Take Up	루퍼 실채기	1	
09-36	GP-045484-00		Lever	바늘대 구동 레버	1	
09-37	GP-045552-00		Link	바늘대 구동 링크	1	
09-38	SN-000289-00		Pin	바늘대 구동 링크 너트	2	
09-39	SC-001688-00		Screw	바늘대 구동 링크 나사	2	
09-40	PN-000756-00		Pin	바늘대 구동 링크 핀	1	
09-41	GP-046413-00		Oil Wick	유심(Φ3x36mm)	2	
09-42	DSC-CB002000		Screw	나사	1	
09-43	AS-016144-00		Bushing Assy.	바늘대 ASSY.	1	
09-43-1	BS-000037-00		Bushing	바늘대 부싱	1	
09-43-2	NB-000003-00		Needle Bar	바늘대	1	
09-44	GP-046037-00		Needle Holder Assy.	바늘 잡이	1	
09-45	DSC-CB001400		Screw	나사	2	
09-46	GP-046166-00		Thread Guide	바늘잡이 실안내	1	
09-47	DSC-BB004200		Screw	나사	2	
09-48	GP-046201-00		Needle	바늘	2	
09-49	G-NP-0010		Needle Plate	침판	1	
09-50	09-081S-8670		Screw	나사	2	
09-51	CNB-BJ000100		Bracket (Front)	침판 브라켓 전	1	
09-52	DSC-BF005400		Screw	나사	2	
09-53	CMB-FD000900		Cushion Rubber	쿠션 고무	2	
09-54	CNB-BJ000200		Bracket (Rear)	침판 브라켓 후	1	
09-55	DSC-BF005400		Screw	나사	2	
09-56	CGA-BK000300		Needle Guard (Front)	니들 가드 전	1	
09-57	PSC-AC006300		Screw	나사	2	
09-58	CGA-HG000200		Needle Guard (Rear)	니들 가드 후	1	
09-59	DSC-AA001900		Bolt	나사	1	
09-60	WS-000538-00		Spring Washer	스프링 와셔	1	
09-61	DSC-BF005900		Screw	나사	1	
09-62	CGA-BK000200		Needle Guard (Front)	니들 가드 전	1	
09-63	DSC-BF005400		Screw	나사	1	
09-64	CGA-BK000100		Needle Guard (Rear)	니들 가드 후	1	
09-65	PSC-AC006300		Screw	나사	2	
09-66	CNB-BB000700		Bracket	니들가드 브라켓	1	
09-67	DSC-BF015100		Screw	나사	2	
09-68	GP-045488-00		Connection	크랭크축연결로트A	1	
09-69	GP-045849-00		Crank	상루퍼축크랭크B	1	
09-70	DCL-BB002600		Spacer	루퍼축스페이서A	1	
09-71	WS-000550-00		Washer	와셔(Φ10.2*Φ14.6,t=1)	1	
09-72	AS-016068-00		Upper Looper Holder Assy.	상루퍼잡이(H) (조)	1	
09-72-1	GP-045516-00		Upper Looper Holder A	상루퍼잡이A	1	
09-72-2	CUL-BK000100		Upper Looper Holder Block	상루퍼잡이블럭	1	
09-72-3	GP-045184-00		Upper Looper Holder Base	상루퍼잡이베이스(T)	1	
09-73	GP-045833-00		Upper Looper	상루퍼(#11)	1	
09-74	GP-045835-00		Lower Looper A	하루퍼A	1	
09-75	CLL-CB000200		Crank	하루퍼축크랭크A	1	
09-76	DSC-AC000200		Bolt	고정나사 (M6*P0.75, L=12)	1	
09-77	DSC-CB000700		Screw	고정나사(M5*P0.8,L=5)	1	
09-78	CGA-GB018500		Main Feed Dog	주이송톱니	1	

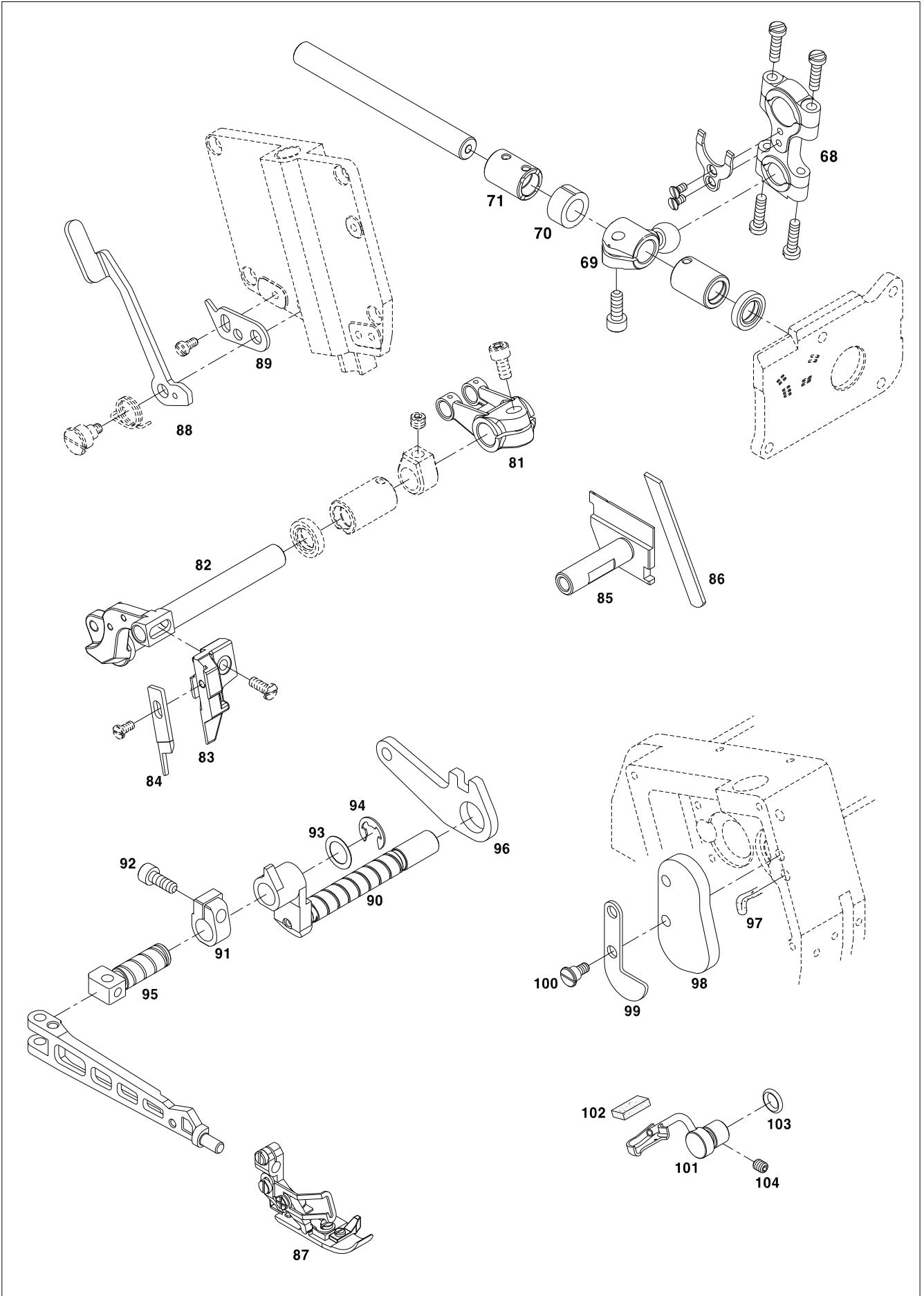

010

Exclusive Parts for SCT 9316-A04/435K-5X5 Mechanism

전용부품 관계 SCT 9316-A04/435K-5X5

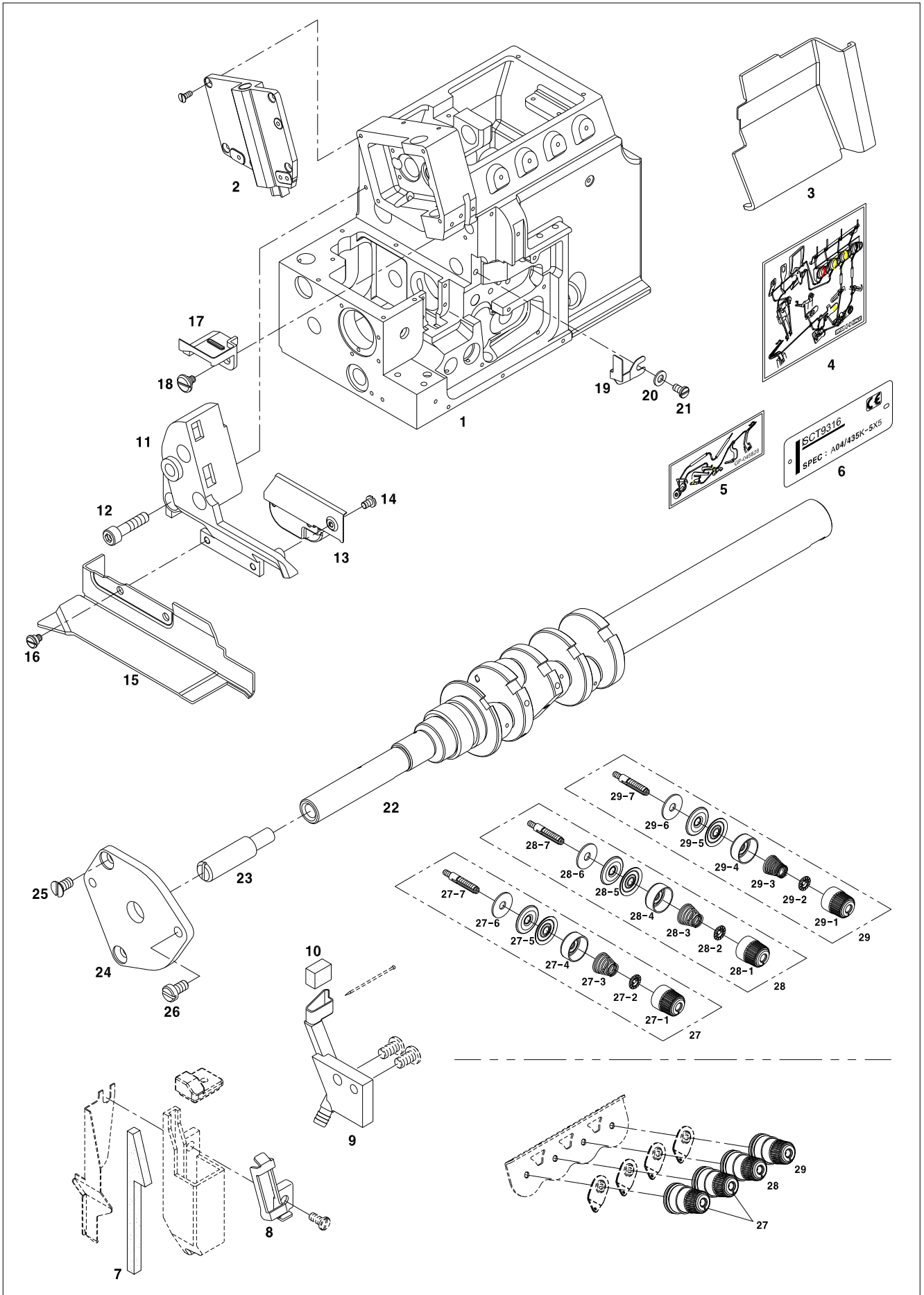

Ref. No.	Parts No.	Note	Name of Parts	품 명	Q'ty	Applied Period
O10-1	GP-045283-02		Frame	프레임	1	
O10-2	GP-045645-00		Face Cover	면판	1	
O10-3	GP-044671-00		Front Cover (Left)	전면커버 (좌)	1	
O10-4	GP-045826-01		Threading Diagram 1	실길 안내 스티커	1	Oct.27.09
O10-5	CMB-LD004600		Threading Diagram 2	실길 안내 스티커	1	
O10-6	GP-045218-00		Model Mark	모델 마크	1	
O10-7	CLB-JL011300		Felt	실리콘 오일 통 felt	1	
O10-8	CTG-BJ000500		Thread Guide	실리콘 오일 통 실안내	1	
O10-9	CMB-JB000700		Silicone Oil Reservoir(Lower)	윗 실 주유기	1	
O10-10	CMB-JL000300		Oil Felt	위실주유기 felt	1	
O10-11	GP-045644-00		Bracket	상피드 브라켓	1	
O10-12	PSC-AC005700		Bolt(M6X25)	상피드 브라켓 고정나사	3	
O10-13	GP-045646-00		Oil Cover	상피드 브라켓 오일커버	1	
O10-14	DSC-BF016000		Bolt(M3X3.5)	상피드 브라켓 오일커버 고정나사	3	
O10-15	GP-045847-00		Fabric Guide	천이송 가이드	1	
O10-16	DSC-BF005000		Screw(M4.5X6)	천이송 가이드 고정나사	2	
O10-17	GP-045647-00		Cover	상피드 톱니 받침 오일커버	1	
O10-18	DSC-FA004800		Screw(M4)	오일커버 고정나사	1	
O10-19	GP-045853-00		Cover	메스 구동축 커버	1	
O10-20	SC-000283-00		Screw(M4X5.4)	메스 구동축 커버 고정나사	1	
O10-21	DWS-CB000300		Spring	메스 구동축 커버 파형와셔	1	
O10-22	ST-000122-00		Crankshaft	주축	1	
O10-23	DPN-BC004400		Pin	주축 핀 前	1	
O10-24	CCS-BJ000200		Cover	주축 커버 前	1	
O10-25	13009SC-4113		Screw	나사	2	
O10-26	SC-000850-00		Screw	나사	1	
O10-27	ATA-PS000900		Thread Tension Device Assembly-Needle	실조절장치(조)-바늘실	2Set	
O10-27-1	DSN-CD000300		Thread Tension Spring Cap Ass'Y	실조절장치 캡(조)	1Set	
O10-27-1-1	GP-001461-00		Thread Tension Spring Cap	실조절장치 캡	1	
O10-27-1-2	GP-001462-00		Bushing For Thread Tension Spring Cap	실조절장치 캡 붓심	1	
O10-27-2	CTA-BN000300		Stopper For Tension Spring	실조절장치 스프링 스톱퍼	1	
O10-27-3	DSP-BA000500		Thread Tension Spring-Needle	실조절장치 스프링-바늘실	1	
O10-27-4	CTA-BD000400		Retainer For Thread Tension Spring Cap	실조절장치 캡받침	1	
O10-27-5	CTA-HL000200		Tension Disc	실조절장치 접시	2	
O10-27-6	CTA-JL000100		Felt For Thread Tension Device	실조절장치 felt	1	
O10-27-7	CTA-HM000400		Thread Tension Post	실조절장치 포스트	1	
O10-28	AS-015472-00		Thread Tension Device Assembly-Needle	실조절장치(조)-루퍼실	1Set	
O10-28-1	DSN-CD000300		Thread Tension Spring Cap Ass'Y	실조절장치 캡(조)	1Set	
O10-28-1-1	GP-001461-00		Thread Tension Spring Cap	실조절장치 캡	1	
O10-28-1-2	GP-001462-00		Bushing For Thread Tension Spring Cap	실조절장치 캡 붓심	1	
O10-28-2	CTA-BN000300		Stopper For Tension Spring	실조절장치 스프링 스톱퍼	1	
O10-28-3	SP-000038-00		Thread Tension Spring-Needle	실조절장치 스프링-루퍼실	1	
O10-28-4	CTA-BD000400		Retainer For Thread Tension Spring Cap	실조절장치 캡받침	1	
O10-28-5	CTA-HL000200		Tension Disc	실조절장치 접시	2	
O10-28-6	CTA-JL000100		Felt For Thread Tension Device	실조절장치 felt	1	
O10-28-7	CTA-HM000400		Thread Tension Post	실조절장치 포스트	1	
O10-29	AS-015473-00		Thread Tension Device Assembly-Looper	실조절장치(조)-루퍼실	1Set	
O10-29-1	DSN-CD000300		Thread Tension Spring Cap Ass'Y	실조절장치 캡(조)	1Set	
O10-29-1-1	GP-001461-00		Thread Tension Spring Cap	실조절장치 캡	1	
O10-29-1-2	GP-001462-00		Bushing For Thread Tension Spring Cap	실조절장치 캡 붓심	1	
O10-29-2	GP-000906-00		Stopper For Tension Spring	실조절장치 스프링 스톱퍼	1	
O10-29-3	SP-000039-00		Thread Tension Spring-Looper	실조절장치 스프링-루퍼실	1	
O10-29-4	CTA-BD000400		Retainer For Thread Tension Spring Cap	실조절장치 캡받침	1	
O10-29-5	CTA-HL000200		Tension Disc	실조절장치 접시	2	
O10-29-6	CTA-JL000100		Felt For Thread Tension Device	실조절장치 felt	1	
O10-29-7	CTA-HM000400		Thread Tension Post	실조절장치 포스트	1	
O10-30	CTG-BK000100		Thread Guide Bracket-Needle	실안내브라켓(바늘실)	1	

010

Exclusive Parts for SCT 9316-A04/435K-5X5 Mechanism

전용부품 관계 SCT 9316-A04/435K-5X5

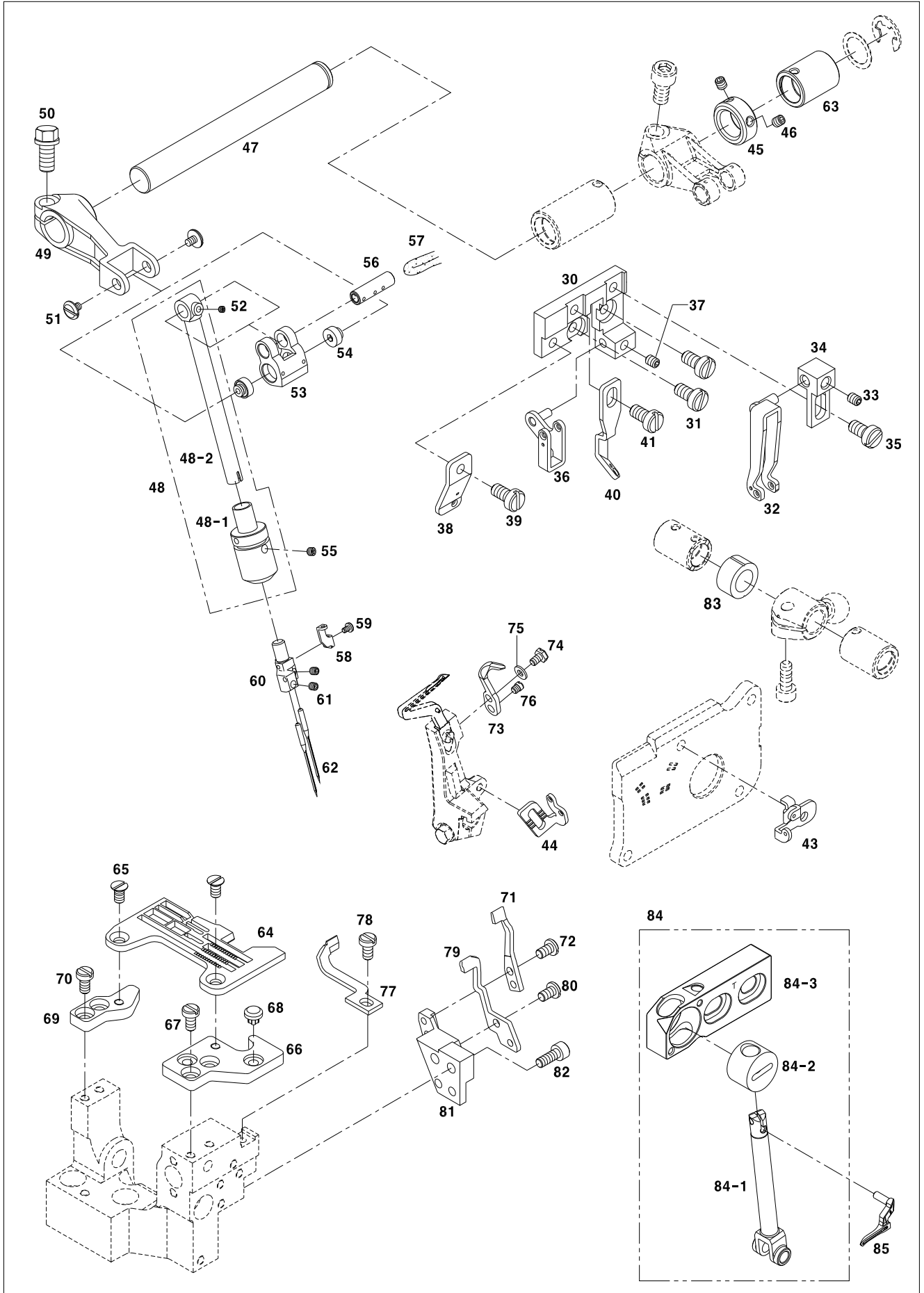

Ref. No.	Parts No.	Note	Name of Parts	품 명	Q'ty	Applied Period
O10-31	DSC-BF005400		Screw(M4Xl8)	나사(M4xL8)	2	
O10-32	ATG-PS000200		Thread Guide Ass'Y	실안내(조)	1Set	
O10-32-1	CTG-BJ000100		Thread Guide	실안내	1	
O10-32-2	DPN-BC000800		Pin	실안내 핀	1	
O10-33	PSC-CB000200		Screw(M4Xl4)	나사(M4xL4)	1	
O10-34	CTG-BB000300		Thread Guide Holder	브라켓	1	
O10-35	DSC-BJ001900		Screw(M4Xl5)	나사(M4xL5)	1	
O10-36	ATG-PS000300		Thread Guide Ass'Y	실안내(조)	1Set	
O10-36-1	CTG-BJ000200		Thread Guide	실안내	1	
O10-36-2	DPN-BC000800		Pin	실안내 핀	1	
O10-37	PSC-CB000200		Screw(M4Xl4)	나사(M4xL4)	1	
O10-38	GP-045229-00		Thread Guide	실안내	1	
O10-39	DSC-BJ001900		Screw(M4Xl5)	나사(M4xL5)	1	
O10-40	CTG-BJ000400		Thread Guide	실안내	1	
O10-41	DSC-BJ001900		Screw(M4Xl5)	나사(M4xL5)	1	
O10-42	CTH-BJ000100		Needle Thread Take Up	바늘 실채기	1	
O10-43	GP-045233-00		Thread Guide	실안내	1	
O10-44	GP-044859-00		Looper Thread Take Up	루퍼 실채기	1	
O10-45	CL-000334-00		Collar	상피드 구동축 카라	1	
O10-46	DSC-CB001400		Screw	나사	2	
O10-47	ST-000095-00		Shaft	상피드 구동 축	1	
O10-48	AS-016144-00		Bushing Assy.	바늘대 부싱 ASSY.	1	
O10-48-1	BS-000037-00		Bushing	바늘대 부싱	1	
O10-48-2	NB-000002-00		Needle Bar	바늘대	1	
O10-49	GP-045484-00		Lever	바늘대 구동 레버	1	
O10-50	DSC-AA001400		Bolt	볼트	1	
O10-51	SC-001688-00		Screw	나사	2	
O10-52	DSC-CB002000		Screw	나사	1	
O10-53	GP-045552-00		Crank	바늘대 구동 링크	1	
O10-54	SN-000289-00		Nut	바늘대 구동링크 너트	2	
O10-55	SC-001703-00		Screw	나사	1	
O10-56	PN-000756-00		Pin	바늘대 구동 링크 핀	1	
O10-57	GP-046413-00		Oil Wick	유심(Φ3x36mm)	2	
O10-58	GP-046166-00		Thread Guide	바늘잡이 실안내	1	
O10-59	DSC-BB004200		Screw	나사	1	
O10-60	GP-046038-00		Needle Holder Assy.	바늘 잡이	1	
O10-61	DSC-CB001400		Screw	나사	3	
O10-62	GP-046202-00		Needle	바늘	3	
O10-63	BS-000042-00		Rear Bush For Driving Needle Bar	바늘대 구동축 후붓싱	1	
O10-64	G-NP-0010		Needle Plate	침판	1	
O10-65	09-081S-8670		Screw	나사	2	
O10-66	CNB-BJ000100		Bracket (Front)	침판 브라켓 前	1	
O10-67	DSC-BF005400		Screw	나사	2	
O10-68	CMB-FD000900		Cushion Rubber	쿠션 고무	2	
O10-69	CNB-BJ000200		Bracket (Rear)	침판 브라켓 後	1	
O10-70	DSC-BF005400		Screw	나사	2	
O10-71	CGA-BK000300		Needle Guard (Front)	니들 가드 前	1	
O10-72	PSC-AC006300		Screw	나사	2	
O10-73	CGA-HG000200		Needle Guard (Rear)	니들 가드 後	1	
O10-74	DSC-AA001900		Bolt	나사	1	
O10-75	WS-000538-00		Spring Washer	스프링 와셔	1	
O10-76	DSC-BF005900		Screw	나사	1	
O10-77	CGA-BK000200		Needle Guard (Front)	니들 가드 前	1	
O10-78	DSC-BF005400		Screw	나사	1	
O10-79	CGA-BK000100		Needle Guard (Rear)	니들 가드 後	1	
O10-80	PSC-AC006300		Screw	나사	2	
O10-81	CNB-BB000700		Bracket	니들가드 브라켓	1	

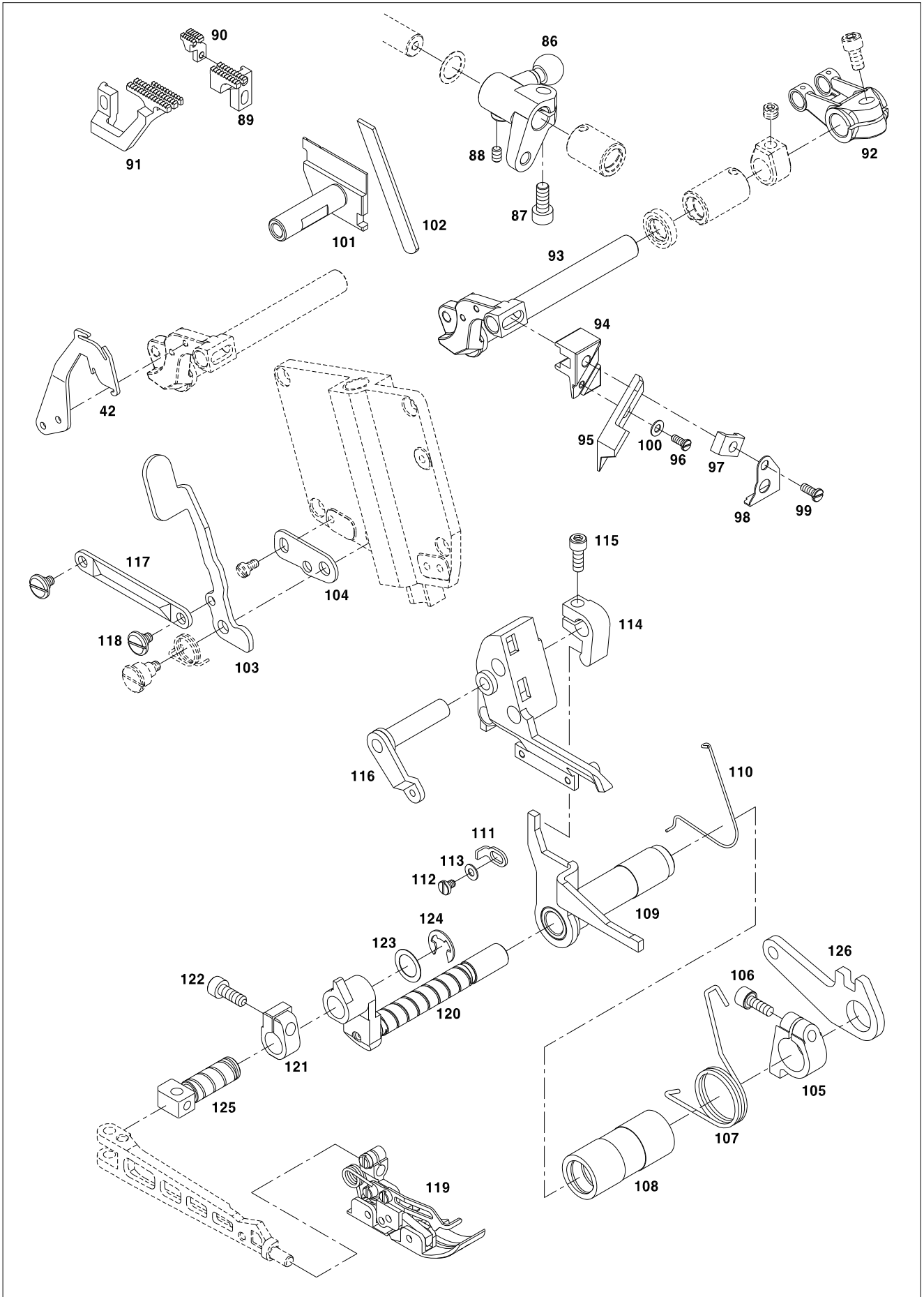



Ref. No.	Parts No.	Note	Name of Parts	품 명	Q'ty	Applied Period
O10-82	DSC-BF015100		Screw	나사	2	
O10-83	DCL-BB002600		Spacer	루퍼축스페이서A	1	
O10-84	AS-016067-00		Upper Looper Holder Assy.	상루퍼잡이(T) (조)	1Set	
O10-84-1	CUL-BF000100		Upper Looper Holder	상루퍼잡이	1	
O10-84-2	CUL-BK000100		Upper Looper Holder Block	상루퍼잡이블럭	1	
O10-84-3	GP-045184-00		Upper Looper Holder Base	상루퍼잡이베이스(T)	1	
O10-85	GP-045830-00		Upper Looper	상루퍼(#03)	1	
O10-86	CLL-CB000200		Crank	하루퍼축크랭크A	1	
O10-87	DSC-AC000200		Bolt	M6*P0.75, L=12	1	
O10-88	DSC-CB000700		Screw	무두나사(M5*P0.8,L=5)	1	
O10-89	CGA-GB018500		Main Feed Dog	주이송톱니	1	
O10-90	CGA-GB018600		Auxiliary Feed Dog	보조 톱니	1	
O10-91	CGA-GB018700		Differential Feed Dog	차동이송 톱니	1	
O10-92	CCT-CB000300		Crank	메스 구동축 크랭크	1	
O10-93	ST-000062-00		Upper Knife Lever	메스 구동축	1	
O10-94	GP-045588-00		Angled Upper Knife Clamp	이동메스 클램프(Angled Type)	1	
O10-95	GP-045589-00		Angled Knife	이동메스(Angled Type)	1	
O10-96	SC-000396-02		Screw	나사(1/8" n=44, L3.7)	1	
O10-97	GP-045590-00		Angled Upper Knife Gib	이동메스 깃(Angled Type)	1	
O10-98	GP-045591-00		Waste Guard	웨이스트 가드	1	
O10-99	PSC-AC005000		Screw	나사(M4xL22)	1	
O10-100	WS-000580-00		Washer	고정용 와셔	1	
O10-101	CCT-BF001201		Lower Knife Holder	고정 메스 홀더	1	Feb.25.11
O10-102	GP-045235-00		Lower Knife (Thick)	고정메스	1	
O10-103	GP-045529-01		Lever	누름대 레버 A	1	
O10-104	GP-045515-00		Stopper	누름대 올림 스톱퍼	1	
O10-105	GP-045550-01		Collar	누름대 올림 크랭크A	1	
O10-106	10-026S-9677		Screw	나사(M5XP0.8 L=12)	1	
O10-107	SP-000056-00		Spring	노루발 올림 스프링	1	
O10-108	BS-000030-00		Bushing	노루발 올림 부싱	1	
O10-109	AS-015531-00		Bracket Ass'Y	상피이드 올림 브라켓	1Set	
O10-109-1	GP-045524-00		Bracket	상피이드 올림 브라켓	1	
O10-109-2	ST-000087-00		Shaft	상피이드 올림 브라켓 축	1	
O10-110	SP-000055-00		Spring	노루발 복귀 스프링	1	
O10-111	GP-045531-00		Stopper	노루발 올림 스톱퍼	1	
O10-112	DSC-BF005000		Screw	나사(M4XP0.7 L=6)	1	
O10-113	DWS-CB000300		Spring	스프링 와셔	1	
O10-114	GP-045536-00		Lever	상피이드 올림 크랭크	1	
O10-115	10-026S-9677		Screw	나사(M5XP0.8 L=12)	1	
O10-116	AS-015532-00		Lever	상피이드 올림 링크 조	1	
O10-116-1	GP-045526-00		Link	상피이드 올림 링크	1	
O10-116-2	ST-000086-00		Shaft	상피이드 올림 축	1	
O10-117	GP-045525-00		Link	노루발 링크	1	
O10-118	SC-001680-00		Screw	상피이드 올림 나사	1	
O10-119	AS-015743-00		Presser Foot Assy.	노루발(조)SCT9316-A04/435K-5X5	1	
O10-120	ST-000085-00		Shaft	노루발 축	1	
O10-121	GP-045520-00		Collar	누름대 올림 크랭크	1	
O10-122	10-026S-9677		M5X12 Bolt	나사(M5XP0.8 L=12)	1	
O10-123	WS-000563-00		Washer	누름대 올림 크랭크 와셔	1	
O10-124	PSR-AC000900		Retaining Ring	E-링	1	
O10-125	GP-045521-00		Shaft	노루발 몸체 잡이	1	
O10-126	GP-045527-00		Lever	노루발 올림 브라켓	1	
O10-127	AS-015518-00		Pump Ass'Y	오일펌프-T (조)	1	
O10-127-1	CLB-BD000300		Pump Housing	오일펌프 몸체	1	
O10-127-2	SC-000715-00		Screw	나사(M6XP1.0,L=5)	1	
O10-128	PPK-BA000500		O Ring	O-링	1	
O10-129	AS-015468-01		Oil Distributor Assy	오일분배기(조)	1	

010

Exclusive Parts for SCT 9316-A04/435K-5X5 Mechanism

전용부품 관계 SCT 9316-A04/435K-5X5

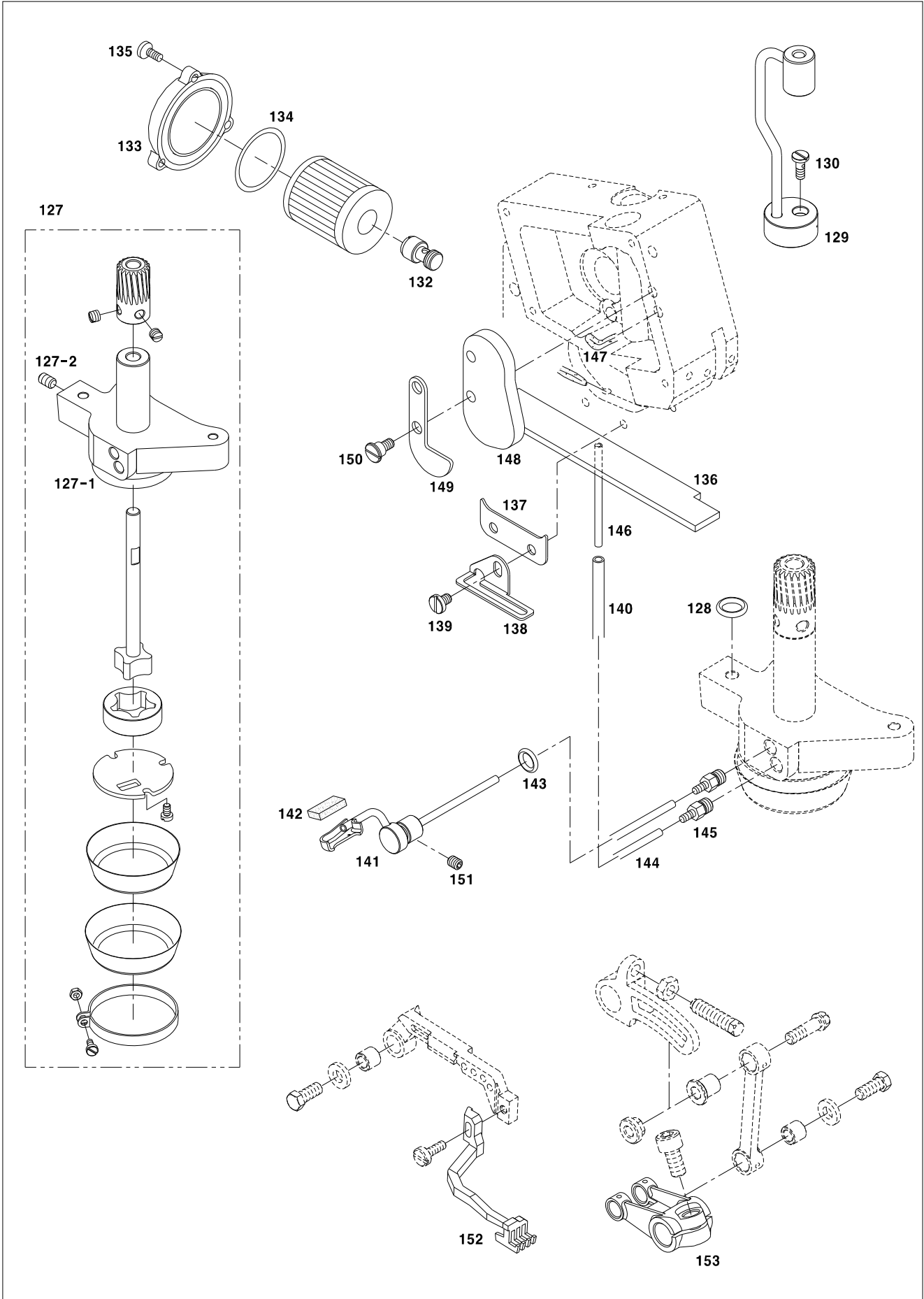

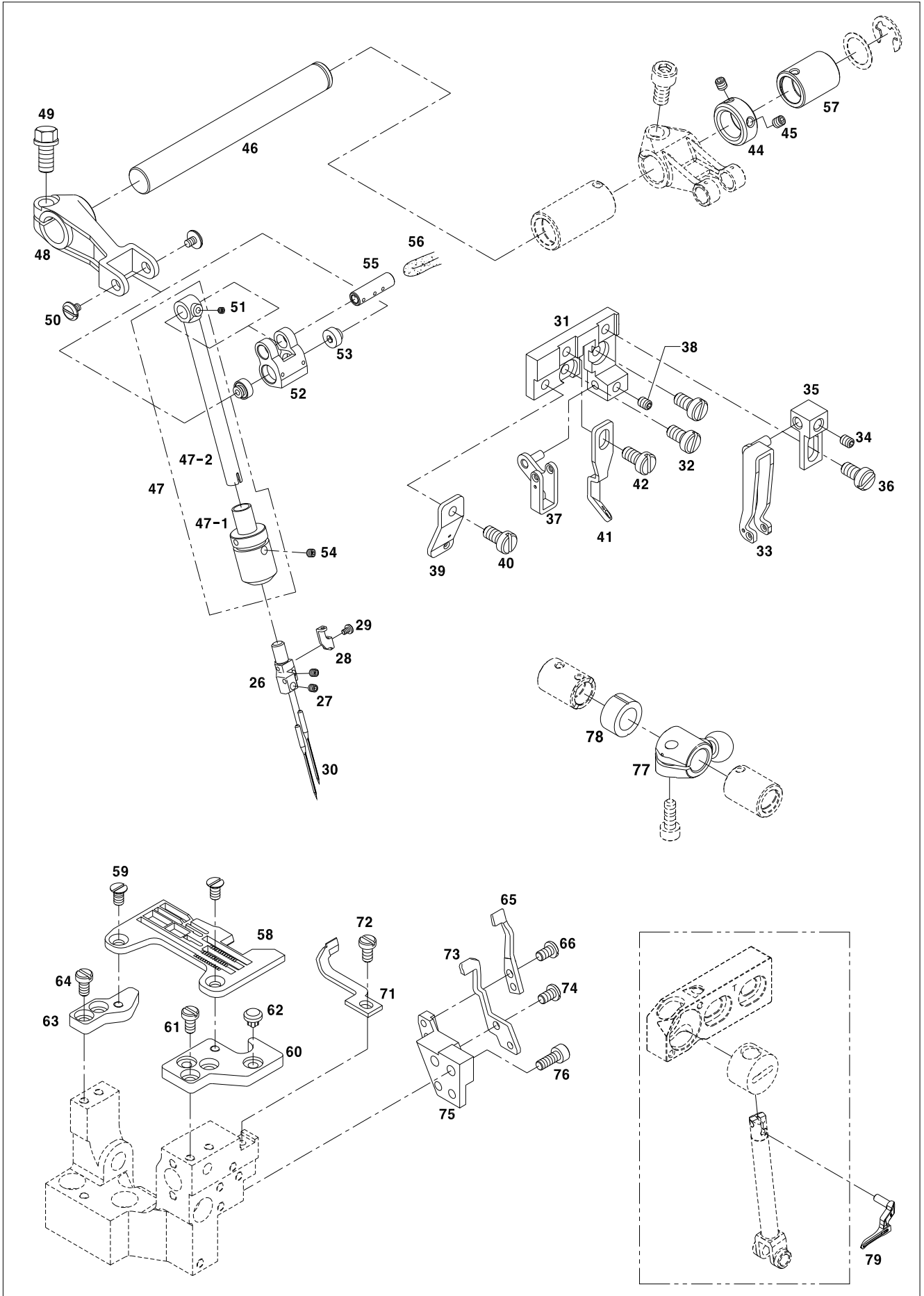

Ref. No.	Parts No.	Note	Name of Parts	품 명	Q'ty	Applied Period
O11-1	GP-045283-02		Frame	프레임	1	
O11-2	GP-045645-00		Face Cover	면판	1	
O11-3	GP-044671-00		Front Cover (Left)	전면커버 (좌)	1	
O11-4	GP-045825-01		Threading Diagram 1	실길 안내 스티커	1	Oct.27.09
O11-5	GP-045828-01		Threading Diagram 2	실길 안내 스티커	1	Oct.27.09
O11-6	GP-045219-00		Model Mark	모델 마크	1	
O11-7	GP-045854-00		Felt	실리콘 오일 통 felt	1	
O11-8	GP-045855-00		Thread Guide	실리콘 오일 통 실안내	1	
O11-9	GP-044930-00		Silicone Oil Reservoir(Lower)	윗 실 주유기	1	
O11-10	CMB-JL000300		Oil Felt	위실주유기 felt	1	
O11-11	GP-045643-00		Bracket	상피드 브라켓	1	
O11-12	PSC-AC005700		Bolt/M6X25	상피드 브라켓 고정나사	3	
O11-13	GP-045646-00		Oil Cover	상피드 브라켓 오일커버	1	
O11-14	SC-000446-00		Bolt/M3X3.5	상피드 브라켓 오일커버 고정나사	3	
O11-15	GP-045847-00		Fabric Guide	천이송 가이드	1	
O11-16	SC-000397-00		Screw/M4.5X6	천이송 가이드 고정나사	2	
O11-17	GP-045647-00		Cover	상피드 톱니 받침 오일커버	1	
O11-18	DSC-FA004800		Screw/M4	오일커버 고정나사	1	
O11-19	GP-045853-00		Cover	메스 구동축 커버	1	
O11-20	SC-000283-00		Screw/M4X5.4	메스 구동축 커버 고정나사	1	
O11-21	WS-000178-00		Spring	메스 구동축 커버 파형와셔	1	
O11-22	PN-000727-00		Pin	주축 핀 前	1	
O11-23	GP-044795-00		Cover	주축 커버 前	1	
O11-24	13009SC-4113		Screw	나사	2	
O11-25	SC-000850-00		Screw	나사	1	
O11-26	GP-046036-00		Needle Holder Assy.	바늘 잡이	1	
O11-27	DSC-CB001400		Screw	나사	2	
O11-28	GP-046165-00		Thread Guide	바늘잡이 실안내	1	
O11-29	SC-001721-00		Screw	나사	1	
O11-30	GP-046200-00		Needle	바늘	2	
O11-31	GP-044836-00		Thread Guide Bracket-Needle	실안내브라켓(바늘실)	1	
O11-32	DSC-BF005400		Screw(M4Xl8)	나사(M4xL8)	2	
O11-33	AS-015392-00		Thread Guide Ass'Y	실안내(조)	1조	
O11-33-1	GP-044837-00		Thread Guide	실안내	1	
O11-33-2	DPN-BC000800		Pin	실안내 핀	1	
O11-34	PSC-CB000200		Screw(M4Xl4)	나사(M4xL4)	1	
O11-35	GP-044838-00		Thread Guide Holder	브라켓	1	
O11-36	DSC-BJ001900		Screw(M4Xl5)	나사(M4xL5)	1	
O11-37	AS-015393-00		Thread Guide Ass'Y	실안내(조)	1조	
O11-37-1	GP-044839-00		Thread Guide	실안내	1	
O11-37-2	DPN-BC000800		Pin	실안내 핀	1	
O11-38	PSC-CB000200		Screw(M4Xl4)	나사(M4xL4)	1	
O11-39	GP-045229-00		Thread Guide	실안내	1	
O11-40	DSC-BJ001900		Screw(M4Xl5)	나사(M4xL5)	1	
O11-41	GP-044841-01		Thread Guide	실안내	1	
O11-42	DSC-BJ001900		Screw(M4Xl5)	나사(M4xL5)	1	
O11-43	GP-045237-00		Needle Thread Take Up	바늘 실채기	1	
O11-44	CL-000334-00		Collar	상피드 구동축 카라	1	
O11-45	DSC-CB001400		Screw	나사	2	
O11-46	ST-000095-00		Shaft	상피드 구동축	1	
O11-47	AS-016144-00		Bushing Assy.	바늘대 부싱 ASSY.	1	
O11-47-1	BS-000037-00		Bushing	바늘대 부싱	1	
O11-47-2	NB-000002-00		Needle Bar	바늘대	1	
O11-48	GP-045484-00		Lever	바늘대 구동 레버	1	
O11-49	DSC-AA001400		Bolt	볼트	1	
O11-50	SC-001688-00		Screw	나사	2	
O11-51	DSC-CB002000		Screw	나사	1	

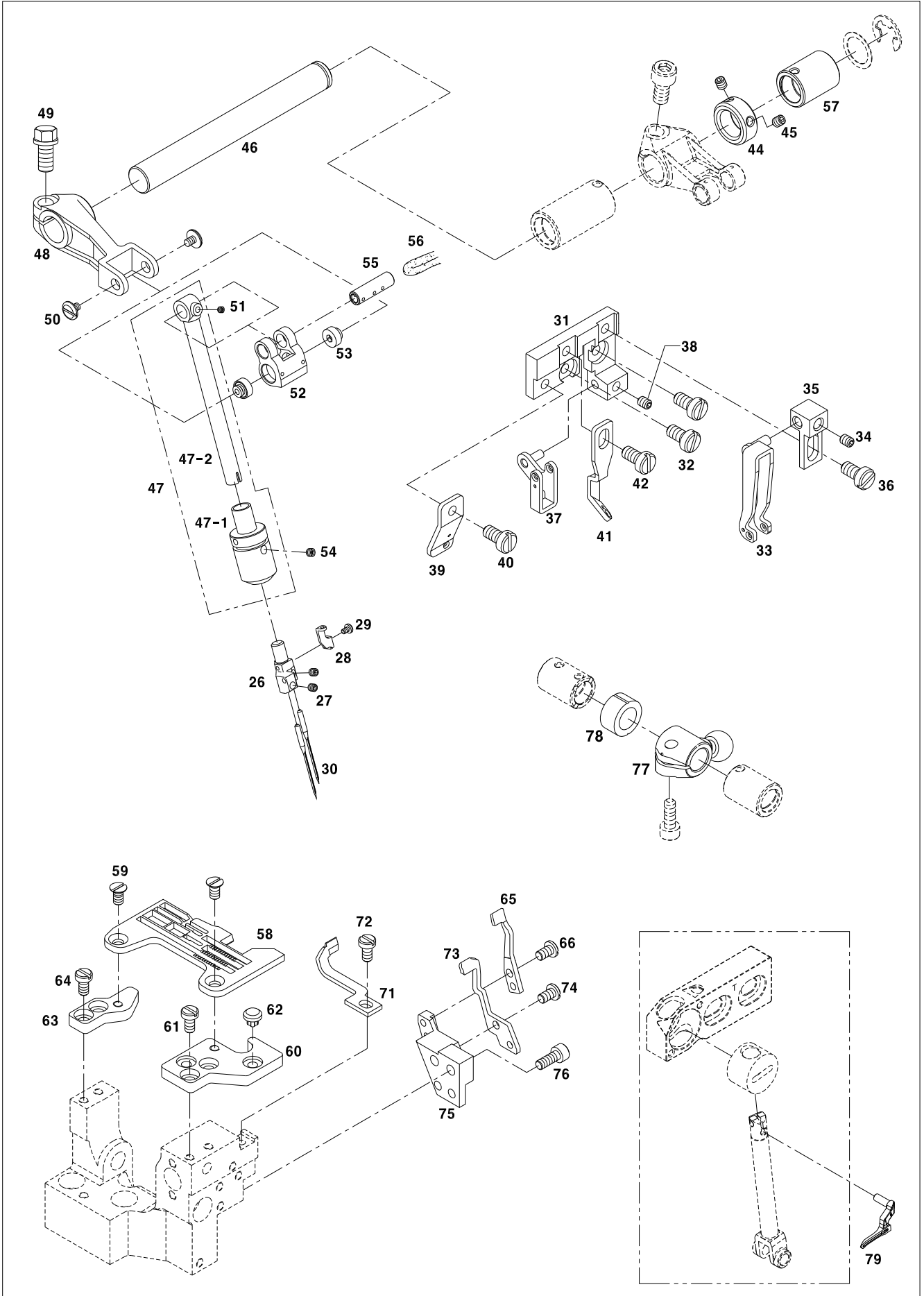

Ref. No.	Parts No.	Note	Name of Parts	품 명	Q'ty	Applied Period
O11-52	GP-045552-00		Crank	비늘대 구동 링크	1	
O11-53	SN-000289-00		Nut	비늘대 구동링크 너트	2	
O11-54	SC-001703-00		Screw	나사	1	
O11-55	PN-000756-00		Pin	비늘대 구동 링크 핀	1	
O11-56	GP-046413-00		Oil Wick	유심(Φ3x36mm)	2	
O11-57	BS-000042-00		Rear Bush For Driving Needle Bar	비늘대 구동축 후붓심	1	
O11-58	G-NP-0010		Needle Plate	침판	1	
O11-59	09-081S-8670		Screw	나사	2	
O11-60	CNB-BJ000100		Bracket (Front)	침판 브라켓 前	1	
O11-61	DSC-BF005400		Screw	나사	2	
O11-62	CMB-FD000900		Cushion Rubber	쿠션 고무	2	
O11-63	CNB-BJ000200		Bracket (Rear)	침판 브라켓 後	1	
O11-64	DSC-BF005400		Screw	나사	2	
O11-65	CGA-BK000300		Needle Guard (Front)	니들 가드 前	1	
O11-66	PSC-AC006300		Screw	나사	2	
O11-67	CGA-HG000200		Needle Guard (Rear)	니들 가드 後	1	
O11-68	DSC-AA001900		Bolt	나사	1	
O11-69	WS-000538-00		Spring Washer	스프링 와셔	1	
O11-70	DSC-BF005900		Screw	나사	1	
O11-71	CGA-BK000200		Needle Guard (Front)	니들 가드 前	1	
O11-72	DSC-BF005400		Screw	나사	1	
O11-73	CGA-BK000100		Needle Guard (Rear)	니들 가드 後	1	
O11-74	PSC-AC006300		Screw	나사	2	
O11-75	CNB-BB000700		Bracket	니들가드 브라켓	1	
O11-76	DSC-BF015100		Screw	나사	2	
O11-77	CUL-CB000300		Crank	상루퍼축크랭크A	1	
O11-78	DCL-BB002600		Spacer	루퍼축스페이서A	1	
O11-79	CGA-HD000200		Upper Looper	상루퍼(#05)	1	
O11-80	CLL-CB000200		Crank	하루퍼축크랭크A	1	
O11-81	DSC-AC000200		Bolt	M6*P0.75, L=12	1	
O11-82	DSC-CB000700		Screw	무두나사(M5*P0.8,L=5)	1	
O11-83	CGA-GB002400		Main Feed Dog	주이송톱니	1	
O11-84	CGA-GB000200		Auxiliary Feed Dog	보조 톱니	1	
O11-85	CGA-GB002500		Differential Feed Dog	차동이송 톱니	1	
O11-86	CCT-CB000300		Crank	메스 구동축 크랭크	1	
O11-87	ST-000062-00		Upper Knife Lever	메스 구동축	1	
O11-88	CCT-BL000200		Upper Knife Clamp	동메스 클램프	1	
O11-89	CCT-NA000100		Plate Knife	동메스 (평형)	1	
O11-90	CCT-BB001800		Lower Knife Holder	고정 메스 홀더	1	
O11-91	CCT-NB000100		Lower Knife (Thick)	고정메스	1	
O11-92	GP-045529-01		Lever	누름대 레버 A	1	
O11-93	GP-045515-00		Stopper	누름대 올림 스톱퍼	1	
O11-94	GP-045550-01		Collar	누름대 올림 크랭크A	1	
O11-95	10-026S-9677		Screw	나사(M5XP0.8 L=12)	1	
O11-96	SP-000056-00		Spring	노루발 올림 스프링	1	
O11-97	BS-000030-00		Bushing	노루발 올림 부싱	1	
O11-98	AS-015531-00		Bracket Ass'Y	상피이드 올림 브라켓	1조	
O11-98-1	GP-045524-00		Bracket	상피이드 올림 브라켓	1	
O11-98-2	ST-000087-00		Shaft	상피이드 올림 브라켓 축	1	
O11-99	SP-000055-00		Spring	노루발 복귀 스프링	1	
O11-100	GP-045531-00		Stopper	노루발 올림 스톱퍼	1	
O11-101	DSC-BF005000		Screw	나사(M4XP0.7 L=6)	1	
O11-102	DWS-CB000300		Spring	스프링 와셔	1	
O11-103	GP-045536-00		Lever	상피이드 올림 크랭크	1	
O11-104	10-026S-9677		Screw	나사(M5XP0.8 L=12)	1	
O11-105	AS-015532-00		Lever	상피이드 올림 링크 조	1	
O11-105-1	GP-045526-00		Link	상피이드 올림 링크	1	

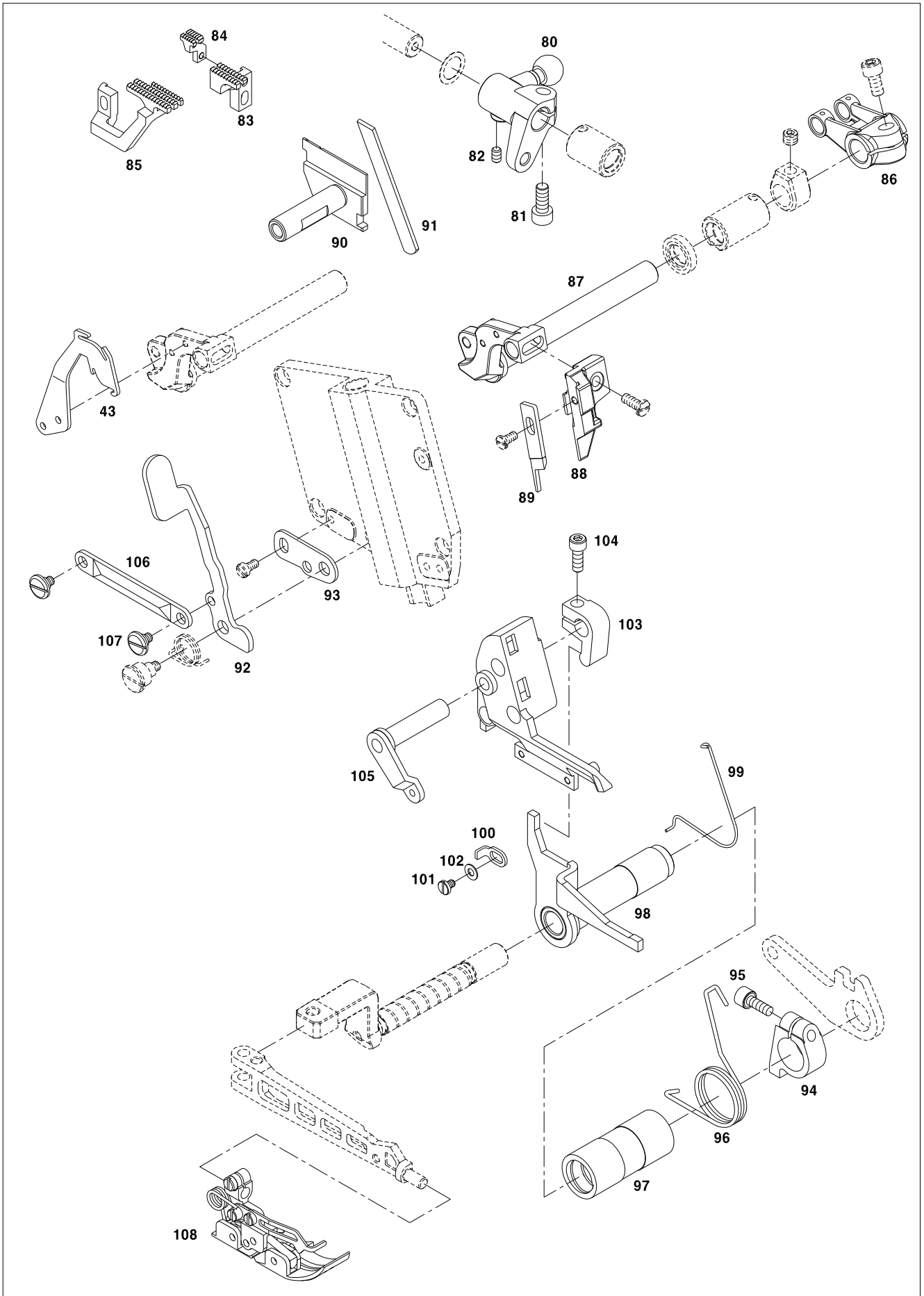

Ref. No.	Parts No.	Note	Name of Parts	품 명	Q'ty	Applied Period
O11-52	GP-045552-00		Crank	비늘대 구동 링크	1	
O11-53	SN-000289-00		Nut	비늘대 구동링크 너트	2	
O11-54	SC-001703-00		Screw	나사	1	
O11-55	PN-000756-00		Pin	비늘대 구동 링크 핀	1	
O11-56	GP-046413-00		Oil Wick	유심(Φ3x36mm)	2	
O11-57	BS-000042-00		Rear Bush For Driving Needle Bar	비늘대 구동축 후붓심	1	
O11-58	G-NP-0010		Needle Plate	침판	1	
O11-59	09-081S-8670		Screw	나사	2	
O11-60	CNB-BJ000100		Bracket (Front)	침판 브라켓 前	1	
O11-61	DSC-BF005400		Screw	나사	2	
O11-62	CMB-FD000900		Cushion Rubber	쿠션 고무	2	
O11-63	CNB-BJ000200		Bracket (Rear)	침판 브라켓 後	1	
O11-64	DSC-BF005400		Screw	나사	2	
O11-65	CGA-BK000300		Needle Guard (Front)	니들 가드 前	1	
O11-66	PSC-AC006300		Screw	나사	2	
O11-67	CGA-HG000200		Needle Guard (Rear)	니들 가드 後	1	
O11-68	DSC-AA001900		Bolt	나사	1	
O11-69	WS-000538-00		Spring Washer	스프링 와셔	1	
O11-70	DSC-BF005900		Screw	나사	1	
O11-71	CGA-BK000200		Needle Guard (Front)	니들 가드 前	1	
O11-72	DSC-BF005400		Screw	나사	1	
O11-73	CGA-BK000100		Needle Guard (Rear)	니들 가드 後	1	
O11-74	PSC-AC006300		Screw	나사	2	
O11-75	CNB-BB000700		Bracket	니들가드 브라켓	1	
O11-76	DSC-BF015100		Screw	나사	2	
O11-77	CUL-CB000300		Crank	상루퍼축크랭크A	1	
O11-78	DCL-BB002600		Spacer	루퍼축스페이서A	1	
O11-79	CGA-HD000200		Upper Looper	상루퍼(#05)	1	
O11-80	CLL-CB000200		Crank	하루퍼축크랭크A	1	
O11-81	DSC-AC000200		Bolt	M6×P0.75, L=12	1	
O11-82	DSC-CB000700		Screw	무두나사(M5×P0.8, L=5)	1	
O11-83	CGA-GB002400		Main Feed Dog	주이송톱니	1	
O11-84	CGA-GB000200		Auxiliary Feed Dog	보조 톱니	1	
O11-85	CGA-GB002500		Differential Feed Dog	차동이송 톱니	1	
O11-86	CCT-CB000300		Crank	메스 구동축 크랭크	1	
O11-87	ST-000062-00		Upper Knife Lever	메스 구동축	1	
O11-88	CCT-BL000200		Upper Knife Clamp	동메스 클램프	1	
O11-89	CCT-NA000100		Plate Knife	동메스 (평형)	1	
O11-90	CCT-BB001800		Lower Knife Holder	고정 메스 홀더	1	
O11-91	CCT-NB000100		Lower Knife (Thick)	고정메스	1	
O11-92	GP-045529-01		Lever	누름대 레버 A	1	
O11-93	GP-045515-00		Stopper	누름대 올림 스톱퍼	1	
O11-94	GP-045550-01		Collar	누름대 올림 크랭크A	1	
O11-95	10-026S-9677		Screw	나사(M5XP0.8 L=12)	1	
O11-96	SP-000056-00		Spring	노루발 올림 스프링	1	
O11-97	BS-000030-00		Bushing	노루발 올림 부싱	1	
O11-98	AS-015531-00		Bracket Ass'Y	상피이드 올림 브라켓	1조	
O11-98-1	GP-045524-00		Bracket	상피이드 올림 브라켓	1	
O11-98-2	ST-000087-00		Shaft	상피이드 올림 브라켓 축	1	
O11-99	SP-000055-00		Spring	노루발 복귀 스프링	1	
O11-100	GP-045531-00		Stopper	노루발 올림 스톱퍼	1	
O11-101	DSC-BF005000		Screw	나사(M4XP0.7 L=6)	1	
O11-102	DWS-CB000300		Spring	스프링 와셔	1	
O11-103	GP-045536-00		Lever	상피이드 올림 크랭크	1	
O11-104	10-026S-9677		Screw	나사(M5XP0.8 L=12)	1	
O11-105	AS-015532-00		Lever	상피이드 올림 링크 조	1	
O11-105-1	GP-045526-00		Link	상피이드 올림 링크	1	

011

Exclusive Parts for SCT 9316-03/233-5X5 Mechanism

전용부품 관계 SCT 9316-03/233-5X5

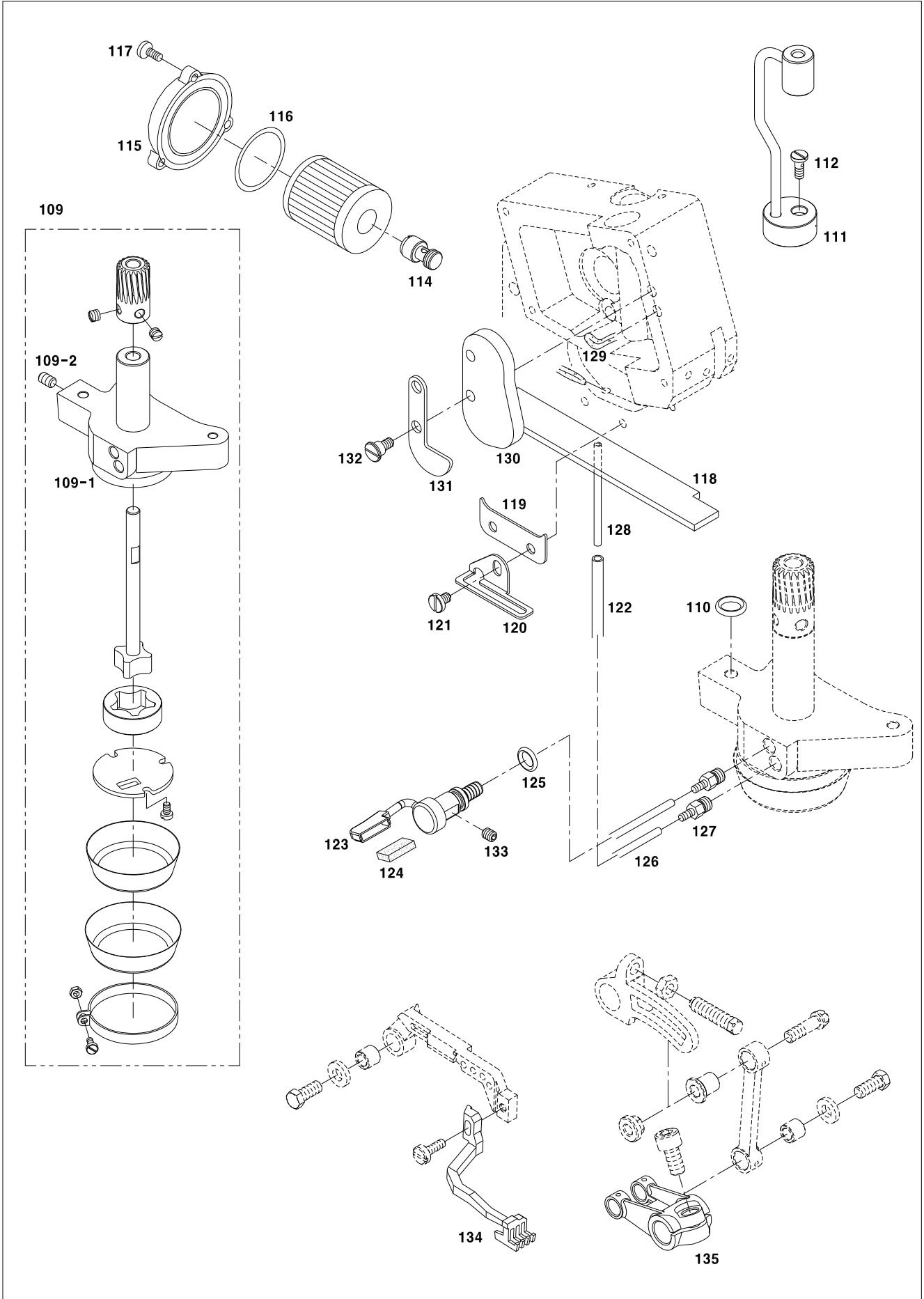

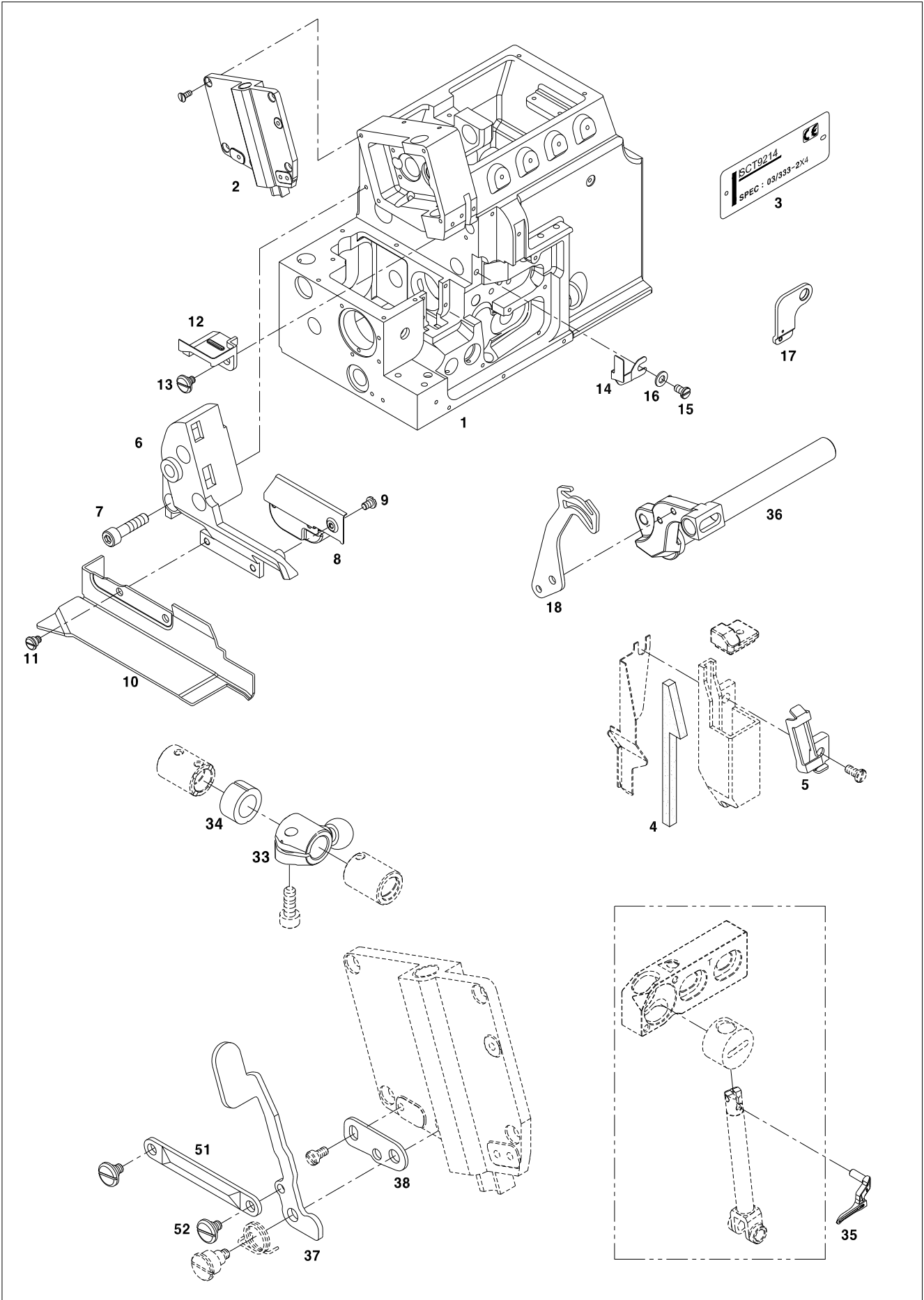

Ref. No.	Parts No.	Note	Name of Parts	품 명	Q'ty	Applied Period
O12-1	GP-045283-02		Frame	프레임	1	
O12-2	GP-045645-00		Face Cover	면판	1	
O12-3	GP-045220-00		Model Mark	모델 마크	1	
O12-4	CMB-JL000200		Felt	실리콘 오일 통 헬트	1	
O12-5	CMB-HK001800		Thread Guide	실리콘 오일 통 실안내	1	
O12-6	GP-045643-00		Bracket	상피드 브라켓	1	
O12-7	PSC-AC005700		Bolt/M6X25	상피드 브라켓 고정나사	3	
O12-8	GP-045646-00		Oil Cover	상피드 브라켓 오일커버	1	
O12-9	DSC-BF016000		Bolt/M3X3.5	상피드 브라켓 오일커버 고정나사	3	
O12-10	GP-045847-00		Fabric Guide	천이송 가이드	1	
O12-11	DSC-BF005000		Screw/M4.5X6	천이송 가이드 고정나사	2	
O12-12	GP-045647-00		Cover	상피드 톱니 받침 오일커버	1	
O12-13	DSC-FA004800		Screw/M4	오일커버 고정나사	1	
O12-14	GP-045853-00		Cover	메스 구동축 커버	1	
O12-15	SC-000283-00		Screw/M4X5.4	메스 구동축 커버 고정나사	1	
O12-16	DWS-CB000300		Spring	메스 구동축 커버 파형와셔	1	
O12-17	GP-045232-00		Thread Guide	실안내	1	
O12-18	GP-045236-00		Needle Thread Take Up	바늘 실채기	1	
O12-19	CL-000334-00		Collar	상피드 구동축 카라	1	
O12-20	DSC-CB001400		Screw	나사	2	
O12-21	ST-000095-00		Shaft	상피드 구동 축	1	
O12-22	AS-016144-00		Bushing Assy.	바늘대 부상 ASSY.	1Set	
O12-22-1	BS-000037-00		Bushing	바늘대 부상	1	
O12-22-2	NB-000002-00		Needle Bar	바늘대	1	
O12-23	GP-045484-00		Lever	바늘대 구동 레버	1	
O12-24	DSC-AA001400		Bolt	볼트	1	
O12-25	SC-001688-00		Screw	나사	2	
O12-26	DSC-CB002000		Screw	나사	1	
O12-27	GP-045552-00		Crank	바늘대 구동 링크	1	
O12-28	SN-000289-00		Nut	바늘대 구동링크 너트	2	
O12-29	SC-001703-00		Screw	나사	1	
O12-30	PN-000756-00		Pin	바늘대 구동 링크 핀	1	
O12-31	GP-046413-00		Oil Wick	유심(Φ3x36mm)	2	
O12-32	BS-000042-00		Rear Bush For Driving Needle Bar	바늘대 구동축 후붓싱	1	
O12-33	CUL-CB000300		Crank	상루퍼축 크랭크A	1	
O12-34	DCL-BB002600		Spacer	루퍼축 스페이서A	1	
O12-35	CGA-HD000200		Upper Looper	상루퍼(#05)	1	
O12-36	ST-000062-00		Upper Knife Lever	메스 구동축	1	
O12-37	GP-045529-01		Lever	누름대 레버 A	1	
O12-38	GP-045515-00		Stopper	누름대 올림 스톱퍼	1	
O12-39	GP-045550-01		Collar	누름대 올림 크랭크A	1	
O12-40	10-026S-9677		Screw	나사(M5XP0.8 L=12)	1	
O12-41	SP-000056-00		Spring	노루발 올림 스프링	1	
O12-42	BS-000030-00		Bushing	노루발 올림 부상	1	
O12-43	AS-015531-00		Bracket Ass'Y	상피이드 올림 브라켓	1Set	
O12-43-1	GP-045524-00		Bracket	상피이드 올림 브라켓	1	
O12-43-2	ST-000087-00		Shaft	상피이드 올림 브라켓 축	1	
O12-44	SP-000055-00		Spring	노루발 복귀 스프링	1	
O12-45	GP-045531-00		Stopper	노루발 올림 스톱퍼	1	
O12-46	DSC-BF005000		Screw	나사(M4XP0.7 L=6)	1	
O12-47	DWS-CB000300		Spring	스프링 와셔	1	
O12-48	GP-045536-00		Lever	상피이드 올림 크랭크	1	
O12-49	10-026S-9677		Screw	나사(M5XP0.8 L=12)	1	
O12-50	AS-015532-00		Lever	상피이드 올림 링크 조	1	
O12-50-1	GP-045526-00		Link	상피이드 올림 링크	1	
O12-50-2	ST-000086-00		Shaft	상피이드 올림 축	1	
O12-51	GP-045525-00		Link	노루발 링크	1	

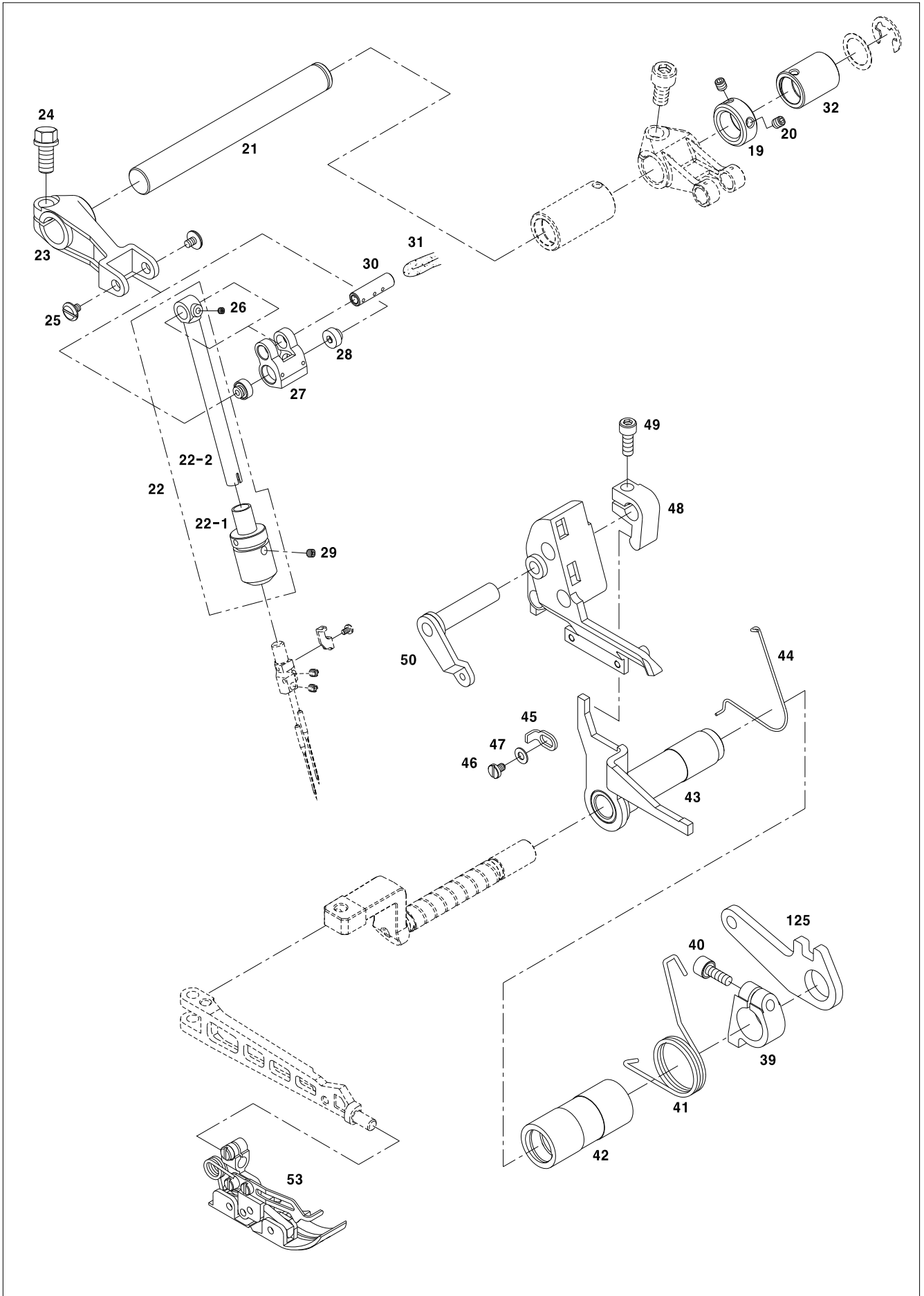

Ref. No.	Parts No.	Note	Name of Parts	품 명	Q'ty	Applied Period
O12-1	GP-045283-02		Frame	프레임	1	
O12-2	GP-045645-00		Face Cover	면판	1	
O12-3	GP-045220-00		Model Mark	모델 마크	1	
O12-4	CMB-JL000200		Felt	실리콘 오일 통 헬트	1	
O12-5	CMB-HK001800		Thread Guide	실리콘 오일 통 실안내	1	
O12-6	GP-045643-00		Bracket	상피드 브라켓	1	
O12-7	PSC-AC005700		Bolt/M6X25	상피드 브라켓 고정나사	3	
O12-8	GP-045646-00		Oil Cover	상피드 브라켓 오일커버	1	
O12-9	DSC-BF016000		Bolt/M3X3.5	상피드 브라켓 오일커버 고정나사	3	
O12-10	GP-045847-00		Fabric Guide	천이송 가이드	1	
O12-11	DSC-BF005000		Screw/M4.5X6	천이송 가이드 고정나사	2	
O12-12	GP-045647-00		Cover	상피드 톱니 받침 오일커버	1	
O12-13	DSC-FA004800		Screw/M4	오일커버 고정나사	1	
O12-14	GP-045853-00		Cover	메스 구동축 커버	1	
O12-15	SC-000283-00		Screw/M4X5.4	메스 구동축 커버 고정나사	1	
O12-16	DWS-CB000300		Spring	메스 구동축 커버 파형와셔	1	
O12-17	GP-045232-00		Thread Guide	실안내	1	
O12-18	GP-045236-00		Needle Thread Take Up	바늘 실채기	1	
O12-19	CL-000334-00		Collar	상피드 구동축 카라	1	
O12-20	DSC-CB001400		Screw	나사	2	
O12-21	ST-000095-00		Shaft	상피드 구동 축	1	
O12-22	AS-016144-00		Bushing Assy.	바늘대 부상 ASSY.	1Set	
O12-22-1	BS-000037-00		Bushing	바늘대 부상	1	
O12-22-2	NB-000002-00		Needle Bar	바늘대	1	
O12-23	GP-045484-00		Lever	바늘대 구동 레버	1	
O12-24	DSC-AA001400		Bolt	볼트	1	
O12-25	SC-001688-00		Screw	나사	2	
O12-26	DSC-CB002000		Screw	나사	1	
O12-27	GP-045552-00		Crank	바늘대 구동 링크	1	
O12-28	SN-000289-00		Nut	바늘대 구동링크 너트	2	
O12-29	SC-001703-00		Screw	나사	1	
O12-30	PN-000756-00		Pin	바늘대 구동 링크 핀	1	
O12-31	GP-046413-00		Oil Wick	유심(Φ3x36mm)	2	
O12-32	BS-000042-00		Rear Bush For Driving Needle Bar	바늘대 구동축 후붓심	1	
O12-33	CUL-CB000300		Crank	상루퍼축 크랭크A	1	
O12-34	DCL-BB002600		Spacer	루퍼축 스페이서A	1	
O12-35	CGA-HD000200		Upper Looper	상루퍼(#05)	1	
O12-36	ST-000062-00		Upper Knife Lever	메스 구동축	1	
O12-37	GP-045529-01		Lever	누름대 레버 A	1	
O12-38	GP-045515-00		Stopper	누름대 올림 스톱퍼	1	
O12-39	GP-045550-01		Collar	누름대 올림 크랭크A	1	
O12-40	10-026S-9677		Screw	나사(M5XP0.8 L=12)	1	
O12-41	SP-000056-00		Spring	노루발 올림 스프링	1	
O12-42	BS-000030-00		Bushing	노루발 올림 부상	1	
O12-43	AS-015531-00		Bracket Ass'Y	상피이드 올림 브라켓	1Set	
O12-43-1	GP-045524-00		Bracket	상피이드 올림 브라켓	1	
O12-43-2	ST-000087-00		Shaft	상피이드 올림 브라켓 축	1	
O12-44	SP-000055-00		Spring	노루발 복귀 스프링	1	
O12-45	GP-045531-00		Stopper	노루발 올림 스톱퍼	1	
O12-46	DSC-BF005000		Screw	나사(M4XP0.7 L=6)	1	
O12-47	DWS-CB000300		Spring	스프링 와셔	1	
O12-48	GP-045536-00		Lever	상피이드 올림 크랭크	1	
O12-49	10-026S-9677		Screw	나사(M5XP0.8 L=12)	1	
O12-50	AS-015532-00		Lever	상피이드 올림 링크 조	1	
O12-50-1	GP-045526-00		Link	상피이드 올림 링크	1	
O12-50-2	ST-000086-00		Shaft	상피이드 올림 축	1	
O12-51	GP-045525-00		Link	노루발 링크	1	

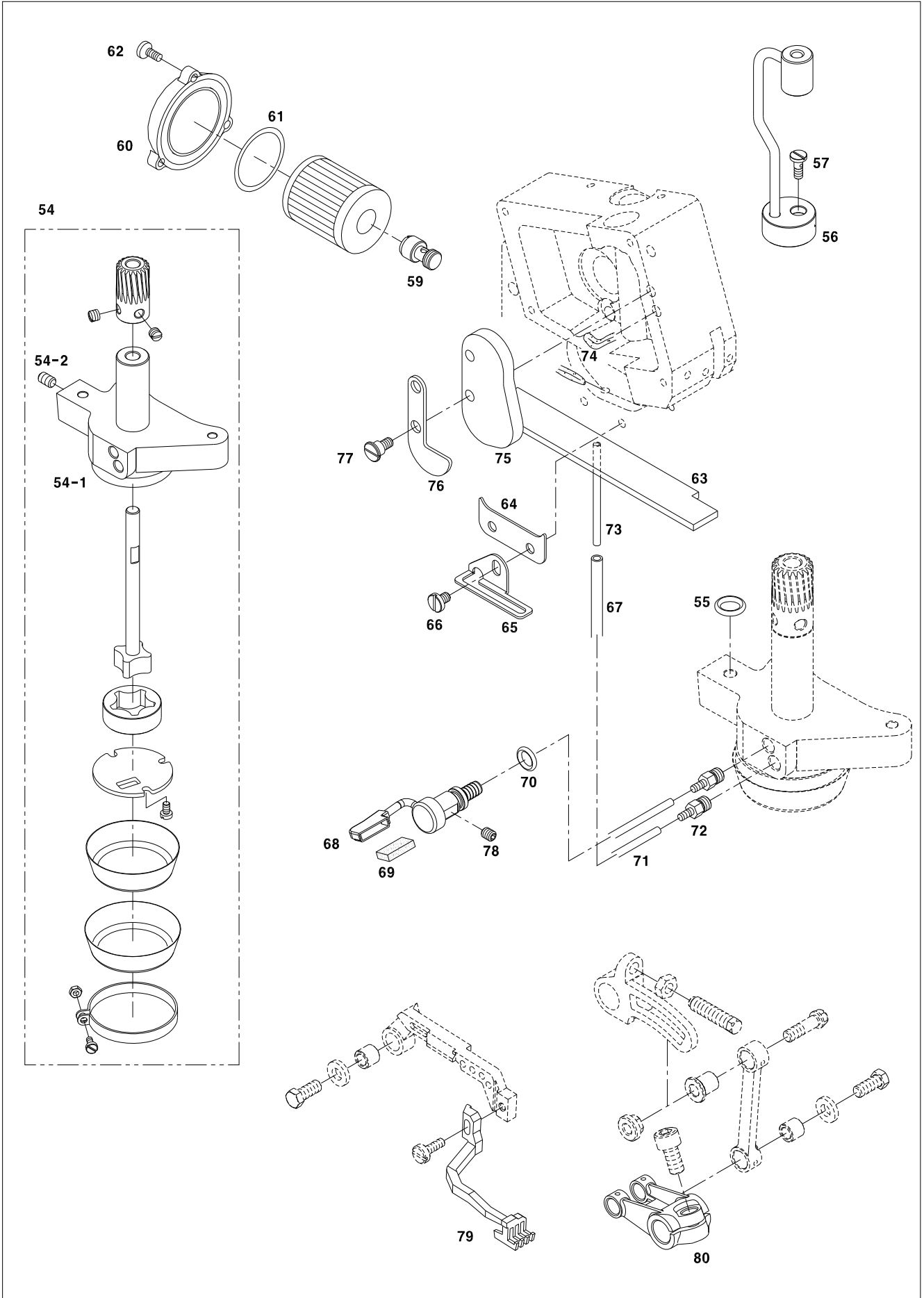

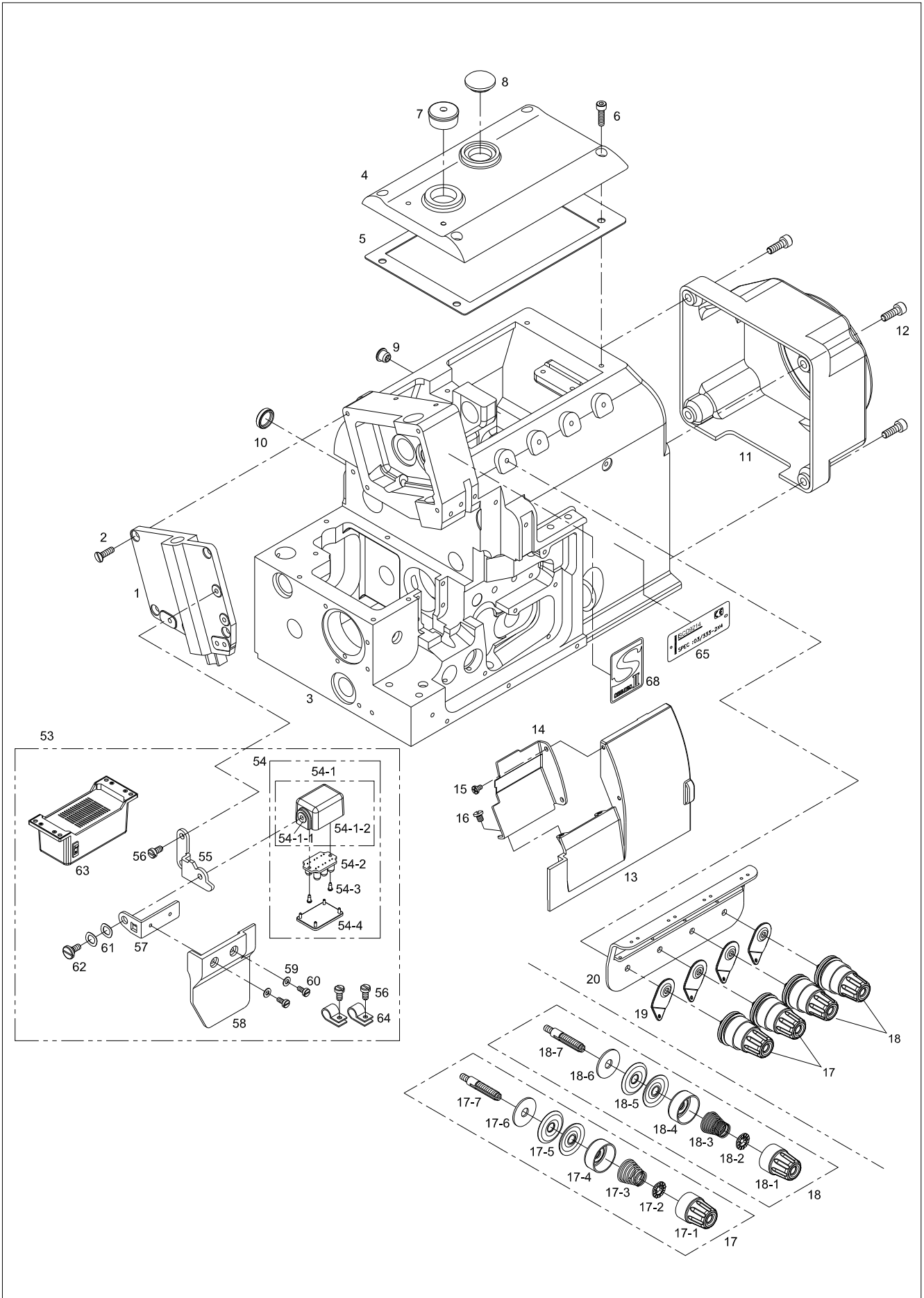

Ref. No.	Parts No.	Note	Name of Parts	품 명	Q'ty	Applied Period
O13-1	CMB-LA017300		Face Plate	면판	1	
O13-2	DSC-BB004100		Screw	접시 작은나사	4	
O13-3	CFR-AC000103		Frame	프레임	1	
O13-4	CMB-LA017601		Top Cover	윗뚜껑	1	Jun.26.12
O13-5	CMB-LA017700		Top Cover Gasket	윗뚜껑 개스킷	1	
O13-6	PSC-AC006200		Bolt	육각구멍볼이 볼트	4	
O13-7	DPK-CB001602		Rubber Cap	부착형 고무마개	1	
O13-8	CLB-JJ000200		Oil Window	유창	1	
O13-9	DPK-CB002900		Rubber Cap	부착형 고무마개	1	
O13-10	DPK-CA000900		Rubber Cap	삽입형 고무마개	1	
O13-11	CMB-LA017100		Motor Cover	모터 커버	1	
O13-12	PSC-AC006100		Bolt	육각구멍볼이 볼트	4	
O13-13	CMB-LA017401		Front Cover(R)	전면 커버(우)	1	
O13-14	CMB-LA017501		Front Cover(L)	전면 커버(좌)	1	Apr.01.11
O13-15	DSC-BJ001800		Screw	등근납작 작은나사	2	
O13-16	DSC-BJ001900		Screw	등근납작 작은나사	2	
O13-17	ATA-PS003500		Looper Thread Tension Adjusting Assembly	루퍼 실장력조절 장치(조)	2Set	
O13-17-1	ATA-PS003600		Thread Adjusting Nut Assembly	실조절너트(조)	1Set	
O13-17-2	CTA-BN000300		Spring Stopper	스프링 스토퍼	1	
O13-17-3	DSP-BA000600		Conical Spring	원추코일 스프링	1	
O13-17-4	CTA-BD000400		Spring Cover	스프링 커버	1	
O13-17-5	CTA-HL000200		Thread Guide Disk	실안내 접시	2	
O13-17-6	CTA-JL000100		Thread Guide Disk Felt	실안내 접시 펠트	1	
O13-17-7	CTA-HM000400		Thread Tension Adjusting Shaft	실조절장치축	1	
O13-18	ATA-PS003400		Needle Thread Tension Adjusting Assembly	비늘 실장력조절 장치(조)	2Set	
O13-18-1	ATA-PS003600		Thread Adjusting Nut Assembly	실조절너트(조)	1Set	
O13-18-2	CTA-BN000300		Spring Stopper	스프링 스토퍼	1	
O13-18-3	DSP-BA000500		Conical Spring	원추코일 스프링	1	
O13-18-4	CTA-BD000400		Spring Cover	스프링 커버	1	
O13-18-5	CTA-HL000200		Thread Guide Disk	실안내 접시	2	
O13-18-6	CTA-JL000100		Thread Guide Disk Felt	실안내 접시 펠트	1	
O13-18-7	CTA-HM000400		Thread Tension Adjusting Shaft	실조절장치축	1	
O13-19	CTA-HK000100		Thread Guide Plate	실안내판	4	
O13-20	CTA-BB001101		Thread Tension Adjusting Assembly Bracket	실장력 조절장치 브래킷	1	
O13-21	CCS-KG000200		Crank Shaft	주축	1	
O13-22	DBS-DA024001		Bushing	일반형 부싱	1	Nov.17.11
O13-23	PSC-CB000700		Set Screw	육각구멍볼이 멈춤나사	2	
O13-24	PSC-AC001200		Bolt	육각구멍볼이 볼트	1	
O13-25	MT-000646-00		Servo Motor(300W)	서보 모터(300W)	1	
O13-26	DSC-AC002000		Bolt	육각구멍볼이 볼트	4	
O13-27	ACS-PS000100		Crank Shaft Pulley	주축 풀리	1	
O13-28	PSC-CB000700		Set Screw	육각구멍볼이 멈춤나사	2	
O13-30	CLB-JP000200		Nipple	니플	6	
O13-31	DSC-BF005300		Screw	납작 작은나사	6	
O13-32	CLB-BH001200		Oil Hose Holder	호스잡이	6	
O13-33	CLB-BK001100		Oil Adjusting Block	유량 조절 블록	1	May.25.11
	CLB-BK000801		Oil Adjusting Block	유량 조절 블록	1	
O13-34	PSC-AC006200		Bolt	육각구멍볼이 볼트	2	
O13-36	DSC-CB000700		Set Screw	육각구멍볼이 멈춤나사	1	
O13-37	CLB-FZ000900		Oil Adjusting Rubber	유량 조절 고무	1	
O13-38	DPK-BA000800		O-Ring	운동용(P) 오링	1	
O13-39	DPK-BA000400		O-Ring	운동용(P) 오링	1	
O13-40	DSC-GA001101		Hinge Screw	이단 납작 단나사	1	
O13-41	CLB-BF001403		Oil Shield Cover	오일 방지 커버	1	
O13-42	CLB-BJ002901		Oil Splasher	오일 분사판	1	
O13-43	CLB-JL010400		Oil Return Felt	환류 펠트	1	
O13-44	CLB-BG005202		Oil Shield Plate Holder	오일 방지판 홀더	1	Mar.18.11

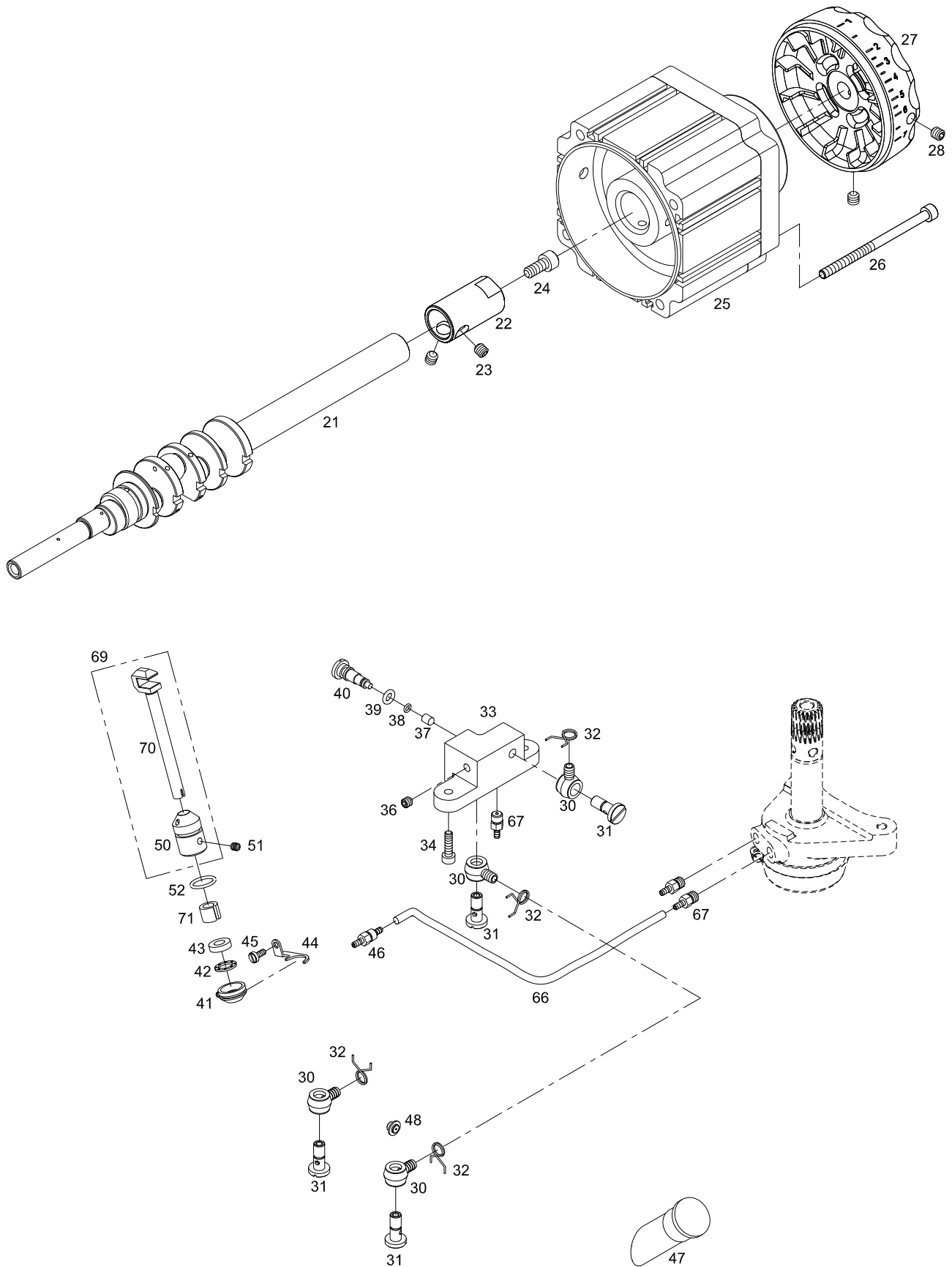

P

Gauge Parts

게이지 파트

기종	게이지		침판	주이송톱니	보조톱니	차동이송톱니	노루발(조)	상루퍼	하루퍼	체인스티치 루퍼
	침간	끝단 폭								
Machine Type / Spec	Gauge		Needle Plate	Main Feed Dog	Aux Feed Dog	Diff. Feed Dog	Presser Foot Ass'y	Upper Looper	Lower Looper	Chain Stitch Looper
	Needle Space	Over Edge Width								
SC9204-01/233-4	-	4	G-NP-0003	CGA-GB0001	CGA-GB0002	CGA-GB0003	AGA-PS0025	CGA-BK0004	CGA-HD0002	-
SC9204-02H/223-3	-	3	G-NP-0004	CGA-GB0031		CGA-GB0030	AGA-PS0029			
SC9214-03/333-2X3	2	3	G-NP-0005	CGA-GB0001	CGA-GB0002	CGA-GB0003	AGA-PS0025	CGA-HD0006	CGA-HD0002	-
SC9214-03/333-2X4	2	4	G-NP-0006				AGA-PS0010			
SC9212-02/333-2X5	2	5	G-NP-0007	CGA-GB0024	CGA-GB0029	CGA-GB0028	AGA-PS0024	CGA-HD0002	CGA-HD0002	-
SC9316-03/233-3X5	3	5	G-NP-0008				CGA-GB0022			
SC9316-03/333-5X5	5	5	G-NP-0009	CGA-GB0185	CGA-GB0185	CGA-GB0187	AS-015740	GP-045830	CGA-HD0001	CGA-HD0005
SC9344-A04/435-5X3X4	5X3	4	G-NP-0011				AS-015739			
SC9316-A04/435-5X5	5	5	G-NP-0010	CGA-GB0185	CGA-GB0185	CGA-GB0187	AS-015741	GP-045833	CGA-HD0001	CGA-HD0005
SC9316H-A05/535-5X5	5	5					GP-046145			
SCT9316-A04/435K-5X5	5	5	G-NP-0009	CGA-GB0024	CGA-GB0002	CGA-GB0025	AS-015744	CGA-HD0002	CGA-HD0002	-
SCT9316-03/233-5X5	5	5	G-NP-0009	CGA-GB0002			CGA-GB0003			
SCT9214-03/333-2X4	2	4	G-NP-0006	CGA-GB0001	CGA-GB0002	CGA-GB0003	AS-015742	CGA-HD0002	CGA-HD0002	-

기종	게이지		이동메스	고정메스	오버록 니들 가드	체인스티치 니들 가드	비늘잡이	바늘	상피드 톱니		
	침간	끝단 폭									
Machine Type / Spec	Gauge		Upper Knife (Flat)	Lower Knife	Overlock needle Guard		Chainstitch Needle Guard		Needle Holder	Needle	Top Feed Dog
	Needle Space	Over Edge Width			Front	Rear	Front	Rear			
SC9204-01/233-4	-	4	CCT-NA0001	CCT-NB0001	CGA-HG0001	-	-	CGA-GD0008	PTC-CA0004 (DCX27 #10)	-	
SC9204-02H/223-3	-	3									
SC9214-03/333-2X3	2	3	CCT-NA0001	CCT-NB0001	CGA-HG0001	-	-	CGA-GD0001	PTC-CA0001 (DCX27 #14)	-	
SC9214-03/333-2X4	2	4									
SC9212-02/333-2X5	2	5	CCT-NA0001	CCT-NB0001	CGA-HG0002	-	-	CGA-BF0004	PTC-CA0001 (DCX27 #14)	-	
SC9316-03/233-3X5	3	5									
SC9316-03/333-5X5	5	5	GP-046179	GP-045235	CGA-BK0003	CGA-BK0002	CGA-BK0001	GP-046039	GP-046202 (DCX27 #21)	GP-046146	
SC9344-A04/435-5X3X4	5X3	4						GP-046038	DOX5 #21		
SC9316-A04/435-5X5	5	5	GP-045589	GP-045235	CGA-BK0003	CGA-BK0002	CGA-BK0001	GP-046037	DOX27 #21	GP-046147	
SC9316H-A05/535-5X5	5	5						GP-046038	DOX27 #14		
SCT9316-A04/435K-5X5	5	5	CCT-NA0001	CCT-NB0001	CGA-GJ0018	-	-	CGA-BF0002	DOX27 #14	GP-045639	
SCT9316-03/233-5X5	5	5						CGA-GD0001	DOX27 #10		
SCT9214-03/333-2X4	2	4	CCT-NA0001	CCT-NB0001	CGA-GJ0018	-	-	CGA-GD0001	DOX27 #10	GP-046147	

Q

Top Feed Mechanism (SCT 9200/9300 Series Only)

상피드 관계 (SCT 9200/9300 시리즈 전용)

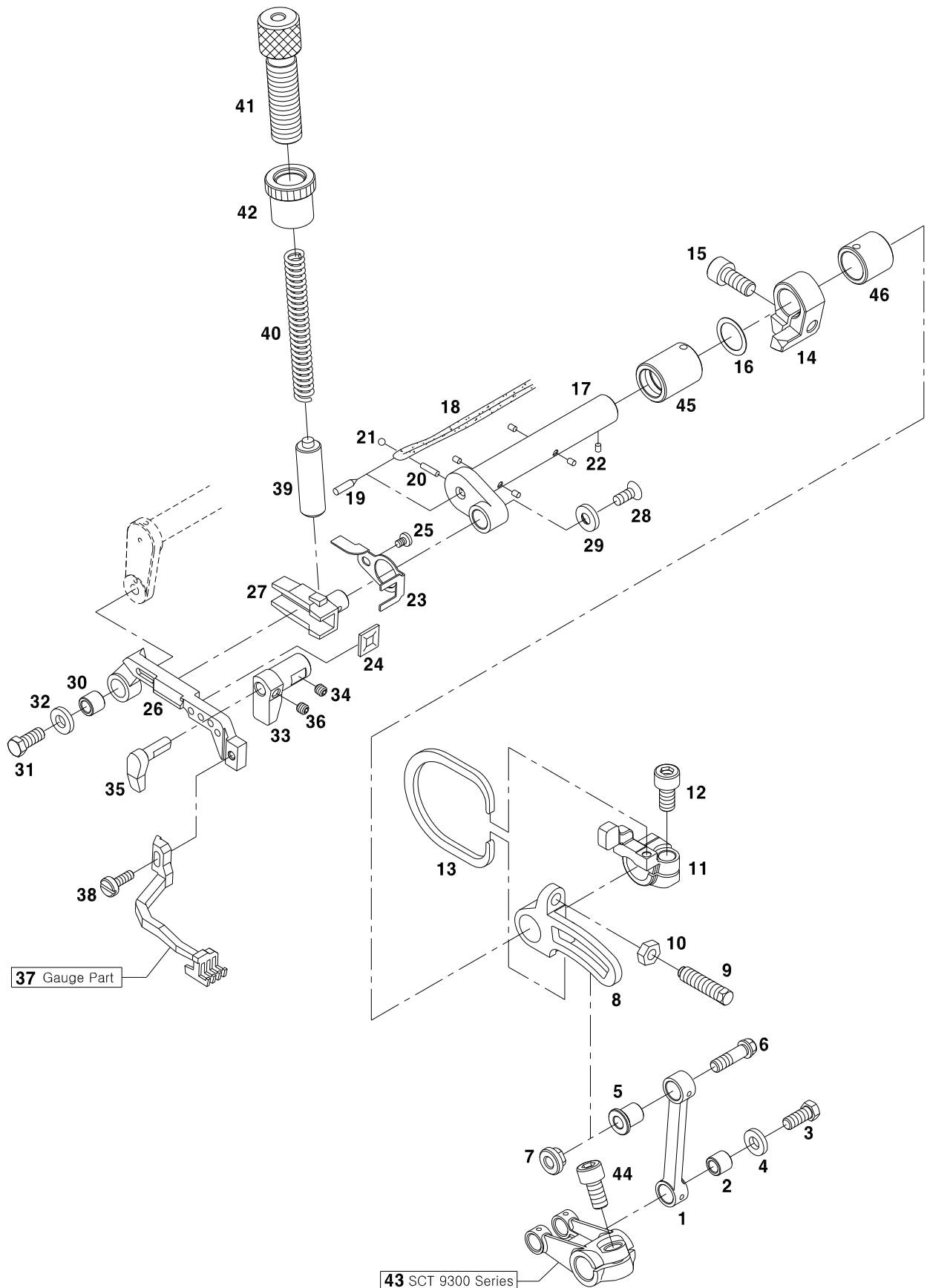

Ref. No.	Parts No.	Note	Name of Parts	품 명	Q'ty	Applied Period
Q-1	GP-045239-00		Connection Link	연결링크	1	
Q-2	DBS-DA004900		Bushing	일반형 붓싱	1	
Q-3	DSC-AA001800		Bolt	육각볼트	5	
Q-4	DWS-AA004501		Washer	원형 평와셔	1	
Q-5	BS-000020-00		Bushing	연결링크 붓싱	1	
Q-6	SC-001646-00		Screw	연결링크 나사	1	
Q-7	SN-000283-00		Nut	연결링크 너트	1	
Q-8	GP-045633-00		Crank	상피드 조절 크랭크	1	
Q-9	SC-001694-00		Screw (M6X23)	나사	1	
Q-10	21-008B-2507		Nut	너트	1	
Q-11	CL-000332-00		Collar	상피드 조절 카라	1	
Q-12	DSC-AC000200		Bolt	육각구멍 불이 볼트	1	
Q-13	SP-000040-00		Flat Spring	상피드판 스프링	1	
Q-14	CL-000333-00		Collar	상피드 들대축 카라	1	
Q-15	DSC-AC000300		Screw (M6X14)	육각구멍 불이 볼트	1	
Q-16	DWS-AA004300		Washer	원형 평와셔	1	
Q-17	ST-000094-00		Top Feed Rocker Shaft	상피드 들대축	1	
Q-18	GP-046413-00		Oil Wick	유심(Φ3,L=36)	1	
Q-19	PN-000759-00		Pin	상피드 들대축 핀	1	
Q-20	GP-045456-00		Felt "B" Of Clank Shaft	상피드 크랭크축 펠트 B	1	
Q-21	GP-045458-00		Ball of crank shaft for upper feed	상피드 크랭크축 볼	1	
Q-22	GP-045457-00		Felt "C" of crank shaft for upper feed	상피드 크랭크축 펠트 C	1	
Q-23	GP-045240-00		Guide	상피드 누름대 오일셀 가이드	1	
Q-24	GP-045634-00		OIL SEAL	상피드 톱니받침 오일셀	1	
Q-25	09-081S-8670		Screw (M6X12)	나사	1	
Q-26	GP-045635-00		Top Feed Dog Support	상피드 톱니 받침	1	
Q-27	GP-045636-00		Top Feed Guide "A"	상피드 톱니받침 가이드 "A"	1	
Q-28	04016MC-8329		Screw	나사	1	
Q-29	WS-000572-00		Washer	와셔	2	
Q-30	DBS-DA004900		Bushing	일반형 부싱	1	
Q-31	DSC-AA001800		Bolt	육각 볼트	1	
Q-32	DWS-AA004501		Washer	원형 평와셔	2	
Q-33	GP-045637-00		Guide "B"	상피드 톱니받침 가이드 "B"	1	
Q-34	PSC-CB000200		Screw	나사	1	
Q-35	GP-045638-00		Guide "C"	상피드 톱니받침 가이드 "C"	1	
Q-36	PSC-CB000200		Screw	나사	1	
Q-37	GP-046146-00		Top Feed Dog	상피드 톱니	1	
Q-38	09-005S-967B		Screw	나사	2	
Q-39	GP-045640-00		Presser Bar	상피드 누름대	1	
Q-40	SP-000061-00		Spring	스프링	2	
Q-41	SC-001695-00		Pressure Regulating Screw	상피드 압력조절 나사	1	
Q-42	SN-000292-00		Nut for Pressure Regulating Screw	상피드 압력조절 나사 너트	1	
Q-43	GP-045641-00		Crank	상피드 들대 크랭크	1	
Q-44	DSC-AC000200		Bolt	육각구멍 불이 볼트	1	
Q-45	BS-000032-00		Front Bushing For Upper Feed Lift Shaft	상피드 들대 축 전붓싱	1	
Q-46	BS-000033-01		Rear Bushing For Upper Feed Lift Shaft	상피드 들대 축 후붓싱	2	
Q-47	CM-000006-00		Eccentric	상피드 편심기	1	
Q-48	DSC-CB000700		Screw (M5X5)	무두나사(M5*P0.8,L=5)	2	
Q-49	WS-000557-00		Washer	와셔	1	
Q-50	GP-045256-00		Connection	상피드 커넥션	1	
Q-51	SC-001655-00		Screw (M4X18)	나사	2	
Q-52	GP-045055-00		Crank	상피드 크랭크 A	1	
Q-53	DSC-AC000200		Bolt (M6X12)	나사	1	
Q-54	ST-000044-00		Shaft	상피드 구동축	1	
Q-55	PSR-AC000600		Retaining Ring	E-링	1	
Q-56	DPK-CB000100		Plug	고무마개	1	
Q-57	DWS-AA004300		Washer	와셔	2	

Q

Top Feed Mechanism (SCT 9200/9300 Series Only)

상피드 관계 (SCT 9200/9300 시리즈 전용)

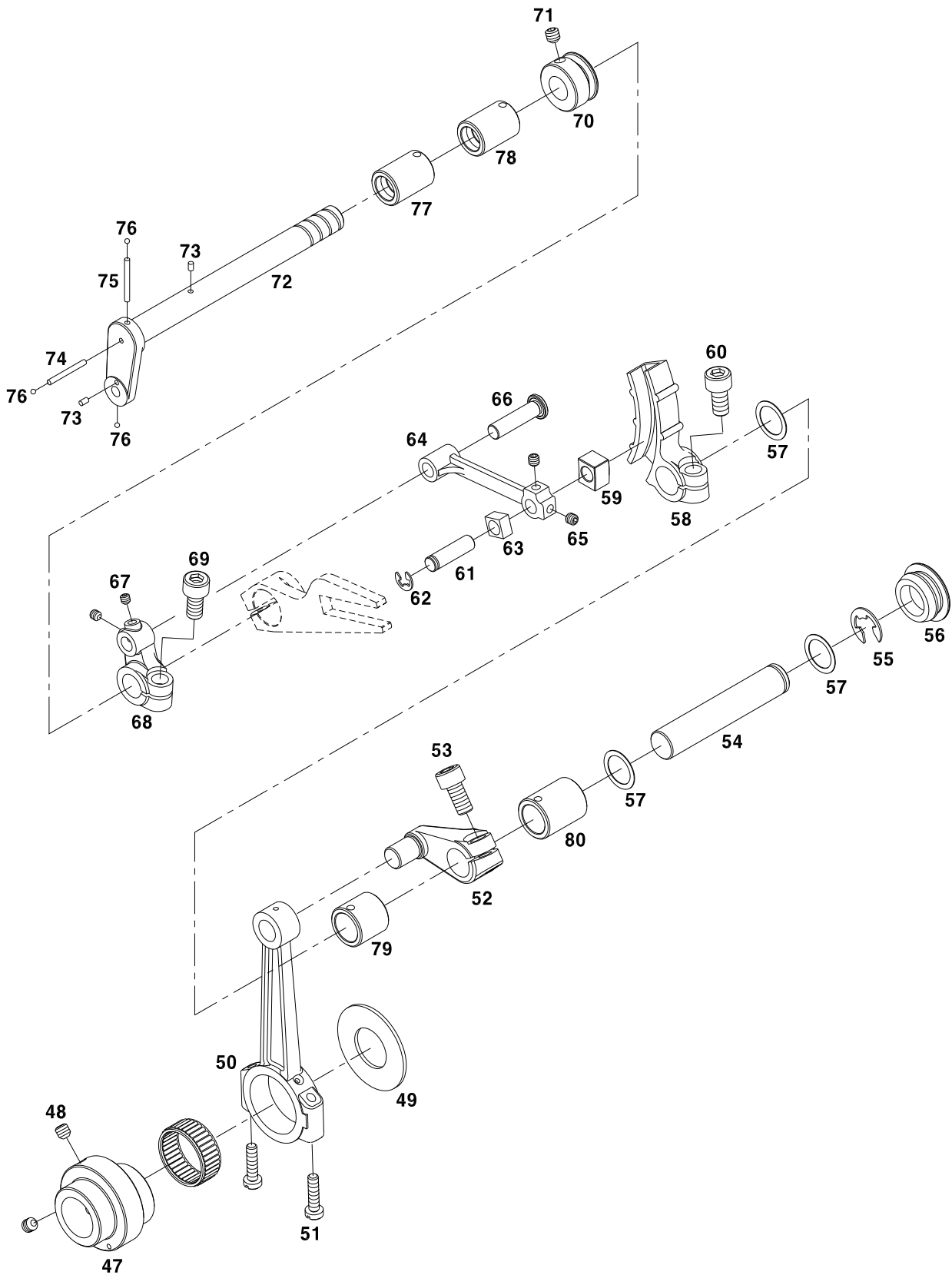

Ref. No.	Parts No.	Note	Name of Parts	품 명	Q'ty	Applied Period
Q-58	GP-045056-00		Crank	상피드 크랭크 B	1	
Q-59	GP-045358-00		Block	상피드 링크블럭 B	1	
Q-60	DSC-AC000200		Bolt (M6X12)	나사	1	
Q-61	PN-000734-00		Pin	상피드 링크핀 A	1	
Q-62	PSR-AC000300		Retaining Ring	E-링	1	
Q-63	GP-045029-00		Block	상피드 링크블럭 A	1	
Q-64	GP-045030-00		Link	상피드 링크	2	
Q-65	PSC-CB000200		M4X4 SCREW	나사	1	
Q-66	PN-000735-00		Pin	상피드 링크핀 B	1	
Q-67	PSC-CB000200		M4X4 SCREW	나사	2	
Q-68	GP-045057-00		Crank	상피드 크랭크 C	1	
Q-69	DSC-AC000200		M6X12 BOLT	나사	1	
Q-70	CL-000322-01		Collar	상피드 크랭크축 카라	1	
Q-71	DSC-CB000700		Screw (M5X5)	무두나사(M5*P0.8,L=5)	1	
Q-72	ST-000051-00		Crank Shaft	상피드 크랭크축	1	
Q-73	GP-045457-00		Felt	상피드 크랭크축 펠트 C	2	
Q-74	GP-045455-00		Felt	상피드 크랭크축 펠트 A	1	
Q-75	GP-045456-00		Felt	상피드 크랭크축 펠트 B	1	
Q-76	GP-045458-00		Ball	상피드 크랭크축 볼	3	
Q-77	BS-000031-02		Front Bushing for Upper Feed Crank Shaft	상피드 크랭크 전봇심	1	
Q-78	DBS-DA005600		Front Bush for Upper Looper Thread Take Up Shaft	상루퍼 실채기축 전봇심	1	
Q-79	BS-000042-00		Rear Bush for Driving Needle Bar	바늘대 구동축 후봇심	1	
Q-80	BS-000041-00		Rear Bush for Driving Upper Feed	상피드 구동축 후봇심	1	
Q-81	GP-044969-00		Lever	상피드레버	1	
Q-82	DSC-AC000300		Bolt (M6XP0.75L14)	볼트(M6XP0.75,L=14)	1	
Q-83	CL-000320-00		Collar	상피드스토퍼카라	1	
Q-84	SC-000367-01		Screw (M6X10)	나사(M6XP1.0,L=12)	1	
Q-85	GP-044970-00		Latch	상피드레취	1	
Q-86	SP-000028-00		Spring	상피드레버 스프링	1	
Q-87	GP-044971-00		Latch	스프링잡이	1	
Q-88	DSC-BF005400		Screw	나사(M4XP0.7,L=8)	1	
Q-89	ST-000040-00		Shaft	상피드조절축	1	
Q-90	DPK-BA000300		O Ring	O링(P7)	1	
Q-91	GP-044972-00		Lever	상피드조절레버	1	
Q-92	09-081S-8670		Screw (M4X7)	접시머리나사(M4XP0.7)	1	
Q-93	13009SC-4113		Screw (M4X10)	접시머리나사(M4XP0.7,L=10)	1	
Q-94	DSN-CZ000300		Nut	조절레버고정너트	1	
Q-95	DSC-BF005100		Screw (M4.5)	조절레버고정나사	1	
Q-96	WS-000043-00		Spring	조절레버접시스프링와셔	1	
Q-97	GP-044974-00		Blade Guide	상피드조절가이드	1	
Q-98	05014SC-7113		Screw (M4X25)	볼트(M4XP0.7,L=25)	3	
Q-99	GP-044975-00		Spacer	고정용 스페이서	3	
Q-100	GP-044973-00		Stopper	상피드조절스토퍼	1	
Q-101	10-020S-300G		Bolt (M5X10)	볼트(M5XP0.8,L=25)	2	
Q-102	SN-000279-00		Nut	스토퍼 너트	2	
Q-103	10-047W-7507		Washer	와셔(φ5.2×φ10.5, t=1)	1	
Q-104	GP-044393-00		Adjusting Bar	피이드 조정 바	1	
Q-105	GP-044402-00		Seal	피이드 라벨	1	
Q-106	DSP-AA002000		Spring	조정 바 스프링	1	
Q-107	PN-000703-00		Pin	조정 바 핀	1	
Q-108	PSR-AC000400		Retaining Ring	E-링	1	

Q

Top Feed Mechanism (SCT 9200/9300 Series Only)

상피드 관계 (SCT 9200/9300 시리즈 전용)

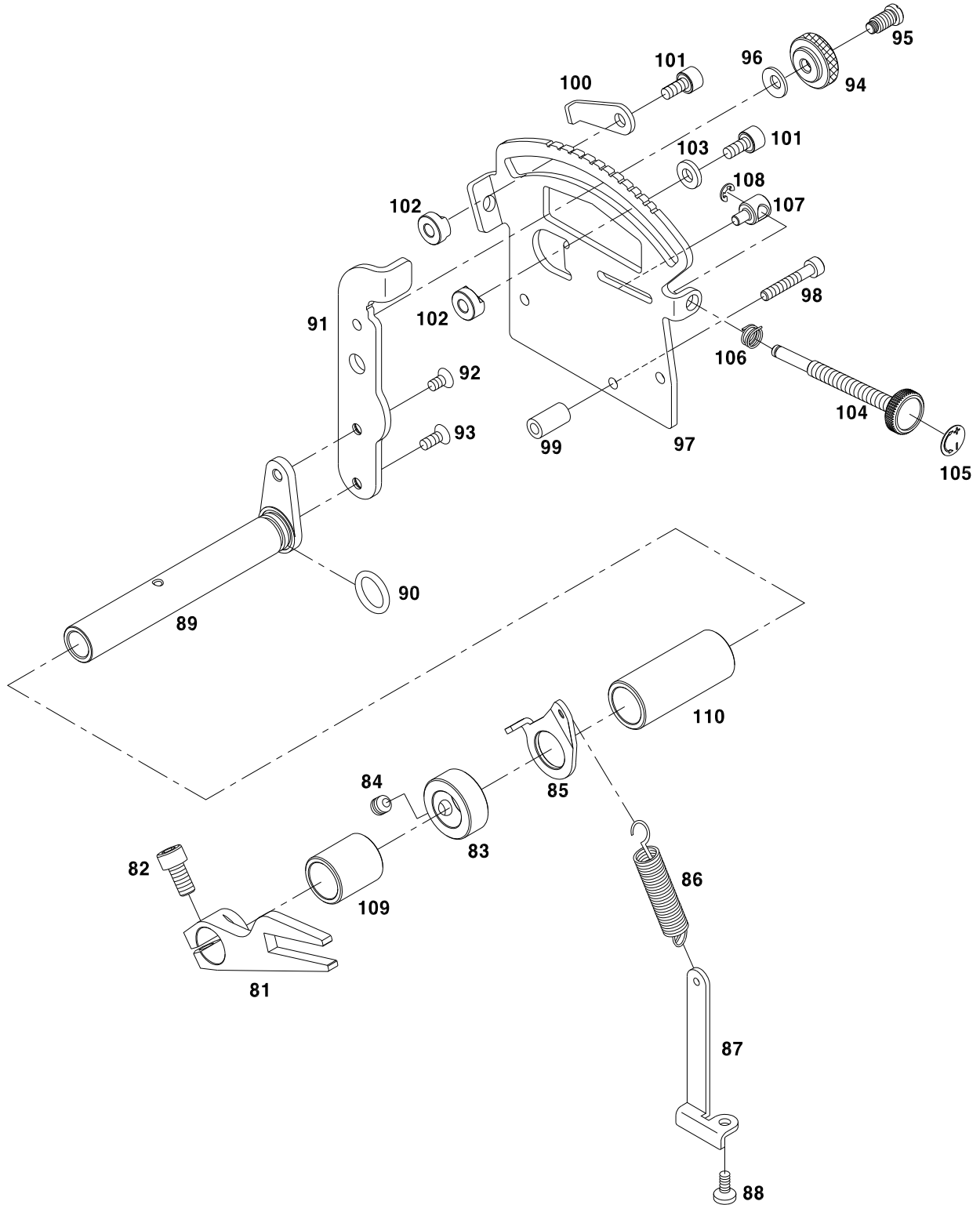

R

Fully Submerged Type Table Mechanism

내림 테이블 관계

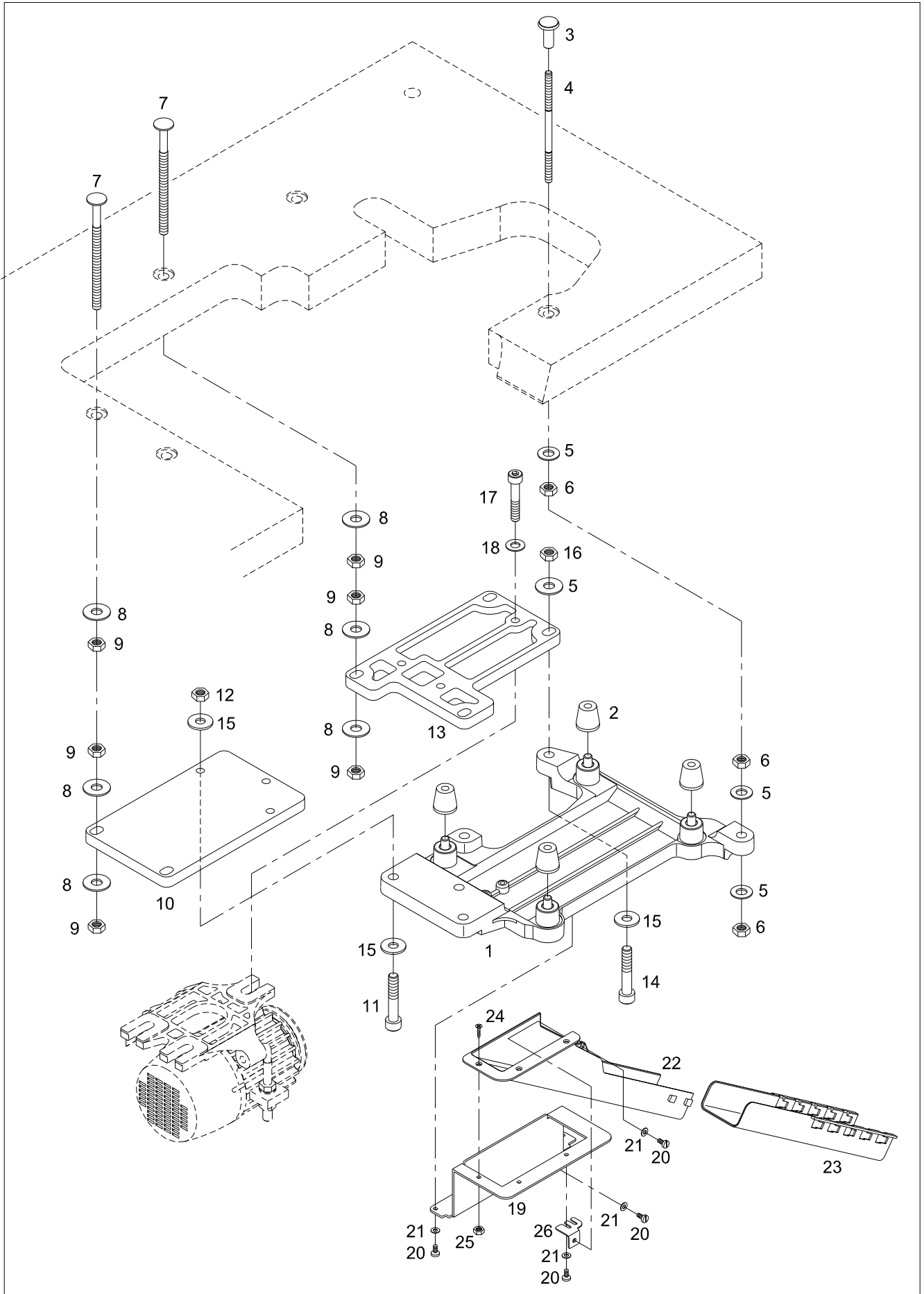

Edge Guide Mechanism (Option)

모서리 가이드 관계 (선택사양)

* SC 9200 Series

SC 9204-01,02
SC 9212-02(H)
SC 9214-01,03

* SC 9300 Series

SC 9215(16)-01,01A,02,02A,03,A04
SC 9344-03,A04
SC 9315(16)H-A05

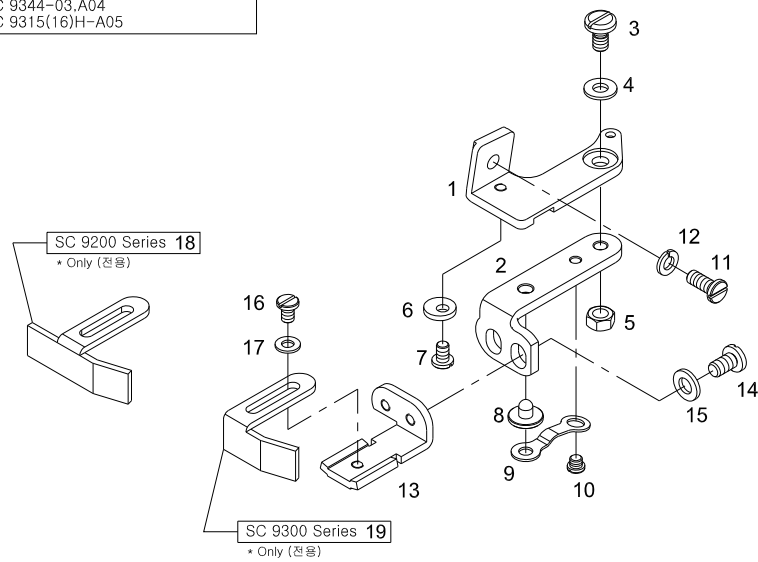

Index

Parts No.	Name of Parts	Page	Ref.No.	Parts No.	Name of Parts	Page	Ref.No.	Parts No.	Name of Parts	Page	Ref.No.
01-035P-7400	Pin	13	B-75	ALP-PS0005	Looper Cam Ass'y	27	I-49	ATA-PS0009	Thread Tension Device Assembly-Needle	17	D-1
01-035P-7400	Pin	13	B-77	AMB-PS0012	Cloth Plate Ass'y (Wide)	11	B-38	ATA-PS0009	Thread Tension Device Assembly-Needle	43	O1-3
04016MC-8329	Screw	105	Q-28	AMB-PS0013	Side Cover (Wide)	11	B-45	ATA-PS0009	Thread Tension Device Assembly-Needle	45	O2-3
05014SC-7113	Screw (M4X25)	107	Q-98	ANB-PS0010	Needle Bar Ass'y	101	O13-69	ATA-PS0009	Thread Tension Device Assembly-Needle	71	O9-16
09-005S-967B	Screw	105	Q-38	APB-PS0001	Presser Bar Assy.	11	B-7	ATA-PS0009	Thread Tension Device Assembly-Needle	77	O10-27
09-081S-8670	Screw	51	O5-28	AS-000294	Pedal for Presser Foot(Ass'y/Nor-Auto, Timmer)	41	N-2	ATA-PS0009	Thread Tension Device Assy-Needle	59	O7-10
09-081S-8670	Screw	55	O6-28	AS-000298	Thread Stand(Ass'y)	41	N-1	ATA-PS0009	Thread Tension Device Assy-Needle	65	O8-10
09-081S-8670	Screw	61	O7-39	AS-015392	Thread Guide Ass'Y	85	O11-33	ATA-PS0010	Thread Tension Device Assembly-Looper	17	D-2
09-081S-8670	Screw	67	O8-34	AS-015393	Thread Guide Ass'Y	85	O11-37	ATA-PS0010	Thread Tension Device Assembly-Looper	43	O1-4
09-081S-8670	Screw	69	O8-34	AS-015435	Joint Assy.	75	O9-101	ATA-PS0010	Thread Tension Device Assembly-Looper	45	O2-4
09-081S-8670	Screw	73	O9-50	AS-015468	Oil Distributor Assy	81	O10-129	ATA-PS0034	Needle Thread Tension Adjusting Assembly	99	O13-18
09-081S-8670	Screw	79	O10-65	AS-015468	Oil Distributor Assy	91	O11-111	ATA-PS0035	Looper Thread Tension Adjusting	99	O13-17
09-081S-8670	Screw	87	O11-59	AS-015468	Oil Distributor Assy	97	O12-56	ATA-PS0036	Thread Adjusting Nut Assembly	99	O13-17-1
09-081S-8670	Screw	89	O11-59	AS-015471	Thread Guide Ass'y	59	O7-20	ATA-PS0036	Thread Adjusting Nut Assembly	99	O13-18-1
09-081S-8670	Screw (M4X7)	107	Q-92	AS-015472	Thread Tension Device Assembly-Needle	71	O9-17	ATA-PS0042	Thread Tension Nut Ass'y	27	I-42
09-081S-8670	Screw (M6X12)	105	Q-25	AS-015472	Thread Tension Device Assembly-Needle	77	O10-28	ATG-PS0001	Thread Guide Ass'y	19	E-1
10-020S-300G	Bolt (M5X10)	107	Q-101	AS-015472	Thread Tension Device Assy-Needle	59	O7-11	ATG-PS0002	Thread Guide Ass'y	51	O5-11
10-026S-9677	Bolt	61	O7-76	AS-015472	Thread Tension Device Assy-Needle	65	O8-11	ATG-PS0002	Thread Guide Ass'y	55	O6-11
10-026S-9677	Bolt	67	O8-71	AS-015473	Thread Tension Device Assembly-Looper	71	O9-18	ATG-PS0002	Thread Guide Ass'y	65	O8-15
10-026S-9677	Bolt	69	O8-71	AS-015473	Thread Tension Device Assembly-Looper	77	O10-29	ATG-PS0002	Thread Guide Ass'Y	71	O9-21
10-026S-9677	M5X12 Bolt	75	O9-92	AS-015473	Thread Tension Device Assy-Looper	59	O7-12	ATG-PS0002	Thread Guide Ass'Y	79	O10-32
10-026S-9677	M5X12 Bolt	81	O10-122	AS-015473	Thread Tension Device Assy-Looper	65	O8-12	ATG-PS0003	Thread Guide Ass'y	51	O5-15
10-026S-9677	Screw	27	I-8	AS-015518	Pump Ass'Y	81	O10-127	ATG-PS0003	Thread Guide Ass'y	55	O6-15
10-026S-9677	Screw	81	O10-106	AS-015518	Pump Ass'Y	91	O11-109	ATG-PS0003	Thread Guide Ass'y	59	O7-24
10-026S-9677	Screw	81	O10-115	AS-015518	Pump Ass'Y	97	O12-54	ATG-PS0003	Thread Guide Ass'y	59	O7-24
10-026S-9677	Screw	87	O11-95	AS-015527	Joint Assy.	83	O10-141	ATG-PS0003	Thread Guide Ass'y	65	O8-19
10-026S-9677	Screw	87	O11-104	AS-015527	Joint Assy.	91	O11-123	ATG-PS0003	Thread Guide Ass'Y	71	O9-25
10-026S-9677	Screw	89	O11-95	AS-015527	Joint Assy.	97	O12-68	ATG-PS0003	Thread Guide Ass'Y	79	O10-36
10-026S-9677	Screw	89	O11-104	AS-015531	Bracket Ass'Y	81	O10-109	ATG-PS0004	Thread Guide Ass'y	43	O1-8
10-026S-9677	Screw	93	O12-40	AS-015531	Bracket Ass'Y	87	O11-98	ATG-PS0004	Thread Guide Ass'y	45	O2-7
10-026S-9677	Screw	93	O12-49	AS-015531	Bracket Ass'Y	89	O11-98	BD-000973	SCD LED Board	101	O13-54-2
10-026S-9677	Screw	95	O12-40	AS-015531	Bracket Ass'Y	93	O12-43	BS-000020	Bushing	105	Q-5
10-026S-9677	Screw	95	O12-49	AS-015531	Bracket Ass'Y	95	O12-43	BS-000030	Bushing	81	O10-108
10-047W-7507	Washer	107	Q-103	AS-015532	Lever	81	O10-116	BS-000030	Bushing	87	O11-97
13009SC-4113	Screw	51	O5-7	AS-015532	Lever	87	O11-105	BS-000030	Bushing	89	O11-97
13009SC-4113	Screw	55	O6-7	AS-015532	Lever	89	O11-105	BS-000030	Bushing	93	O12-42
13009SC-4113	Screw	59	O7-8	AS-015532	Lever	93	O12-50	BS-000030	Bushing	95	O12-42
13009SC-4113	Screw	65	O8-8	AS-015532	Lever	95	O12-50	BS-000031	Front Bushing for Upper Feed Crank Shaft	107	Q-77
13009SC-4113	Screw	71	O9-14	AS-015548	Cloth Guide Bracket Ass'y	113	S-1	BS-000032	Front Bushing For Upper Feed Lift Shaft	105	Q-45
13009SC-4113	Screw	77	O10-25	AS-015739	Presser Foot Assy.	67	O8-68	BS-000033	Rear Bushing For Upper Feed Lift Shaft	105	Q-46
13009SC-4113	Screw	85	O11-24	AS-015739	Presser Foot Assy.	69	O8-68	BS-000034	Front Bushing for Upper Feed Adjust Shaft	109	Q-109
13009SC-4113	Screw (M4X10)	107	Q-93	AS-015740	Presser Foot Assy.	61	O7-73	BS-000035	Rear Bushing for Upper Feed Adjust Shaft	109	Q-110
21-008B-2507	Nut	105	Q-10	AS-015741	Presser Foot Assy.	75	O9-87	BS-000037	Bushing	73	O9-43-1
44-120S-1230	Bolt	113	S-14	AS-015742	Presser Foot Assy.	97	O12-53	BS-000037	Bushing	79	O10-48-1
44-120S-1230	Screw	113	S-16	AS-015743	Presser Foot Assy.	81	O10-119	BS-000037	Bushing	85	O11-47-1
91-020A-300G	Thread Tweezers	41	N-17	AS-015743	Presser Foot Assy.	91	O11-108	BS-000037	Bushing	93	O12-22-1
ACS-PS0001	Crank Shaft Pulley	99	O13-27	AS-015866	Feed Cam	29	J-1	BS-000037	Bushing	95	O12-22-1
AFR-PS0001	Bracket Assy	9	A-6	AS-015867	Ball Bearing Ass'y	15	C-9	BS-000041	Rear Bush for Driving Upper Feed	107	Q-80
AGA-PS0010	Presser Foot Assy.	35	L-19	AS-015868	Crank Assy	29	J-37	BS-000042	Rear Bush For Driving Needle Bar	79	O10-63
AGA-PS0023	Presser Foot Assy.	55	O6-56	AS-015961	Upper Looper Holder (S) Assy	23	G-21	BS-000042	Rear Bush For Driving Needle Bar	87	O11-57
AGA-PS0024	Presser Foot Assy.	51	O5-57	AS-015964	Needle Bar Ass'y	21	F-16	BS-000042	Rear Bush For Driving Needle Bar	89	O11-57
AGA-PS0025	Presser Foot Assy.	43	O1-19	AS-015984	Main Feed Dog Assy	31	J-59	BS-000042	Rear Bush For Driving Needle Bar	93	O12-32
AGA-PS0029	Presser Foot Assy.	45	O2-21	AS-016067	Upper Looper Holder Assy.	61	O7-59	BS-000042	Rear Bush For Driving Needle Bar	95	O12-32
AGA-PS0030	Presser Foot Assy.	47	O3-3	AS-016067	Upper Looper Holder Assy.	67	O8-54	BS-000042	Rear Bush for Driving Needle Bar	107	Q-79
ALA-PS0001	LED Lamp Assembly	101	O13-54	AS-016067	Upper Looper Holder Assy.	69	O8-54	CAC-JB0001	Oiler	41	N-15
ALA-PS0002	LED Body Assembly	101	O13-54-1	AS-016067	Upper Looper Holder Assy.	81	O10-84	CAC-JB0003	Needle Thread Lubrication	13	B-90
ALB-PS0001	Pump Ass'y	37	M-1	AS-016068	Upper Looper Holder Assy.	73	O9-72	CAC-MH0001	Accessory Bag	41	N-5
ALB-PS0002	Rotor (Inside) Shaft	37	M-1-2	AS-016144	Bushing Assy.	73	O9-43	CCS-BJ0001	Cover	15	C-6
ALB-PS0003	Oil Distributor Assy	37	M-22	AS-016144	Bushing Assy.	79	O10-48	CCS-BJ0002	Cover	51	O5-6
ALB-PS0004	Pipe Assy	37	M-34	AS-016144	Bushing Assy.	85	O11-47	CCS-BJ0002	Cover	55	O6-6
ALB-PS0005	Pipe Assy	37	M-36	AS-016144	Bushing Assy.	93	O12-22	CCS-BJ0002	Cover	59	O7-7
ALB-PS0006	Joint	39	M-38	AS-016144	Bushing Assy.	95	O12-22	CCS-BJ0002	Cover	65	O8-7
								CCS-BJ0002	Cover	71	O9-13

Index

Parts No.	Name of Parts	Page	Ref.No.	Parts No.	Name of Parts	Page	Ref.No.	Parts No.	Name of Parts	Page	Ref.No.
CCS-BJ0002	Cover	77	O10-24	CFR-BC0001	Frame	9	A-10	CGA-GB0186	Auxiliary Feed Dog	75	O9-79
CCS-BR0001	Fan Ass'y	15	C-19	CGA-BB0001	Presser Foot Finger	35	L-19-8	CGA-GB0186	Auxiliary Feed Dog	81	O10-90
CCS-DB0001	Balance Weight	15	C-2	CGA-BB0002	Fabric Guide	35	L-19-11	CGA-GB0187	Differential Feed Dog	61	O7-66
CCS-KG0001	Crank Shaft	15	C-1	CGA-BF0001	Holder	35	L-19-1	CGA-GB0187	Differential Feed Dog	67	O8-61
CCS-KG0002	Crank Shaft	99	O13-21	CGA-BF0002	Needle Holder Assy.	55	O6-22	CGA-GB0187	Differential Feed Dog	69	O8-61
CCS-LA0001	Right Cover	15	C-17	CGA-BF0004	Needle Holder Assy.	51	O5-22	CGA-GB0187	Differential Feed Dog	75	O9-80
CCS-LA0002	Cover	15	C-25	CGA-BJ0001	Finger Guard	35	L-19-3	CGA-GB0187	Differential Feed Dog	81	O10-91
CCT-BB0001	Upper Knife Clamp	33	K-12	CGA-BJ0002	Stopper	35	L-19-5	CGA-GC0006	Presser Foot	35	L-19-7
CCT-BB0002	Lower Knife Clamp	33	K-24	CGA-BJ0003	Uncurler	35	L-19-13	CGA-GD0001	Needle Holder Assy.	21	F-23
CCT-BB0018	Lower Knife Holder	51	O5-56	CGA-BK0001	Needle Guard (Rear)	51	O5-42	CGA-GD0008	Needle Holder Assy.	43	O1-11
CCT-BB0018	Lower Knife Holder	55	O6-55	CGA-BK0001	Needle Guard (Rear)	55	O6-42	CGA-GD0008	Needle Holder Assy.	45	O2-10
CCT-BB0018	Lower Knife Holder	87	O11-90	CGA-BK0001	Needle Guard (Rear)	61	O7-53	CGA-HD0001	Lower Looper	25	H-14
CCT-BB0018	Lower Knife Holder	89	O11-90	CGA-BK0001	Needle Guard (Rear)	67	O8-48	CGA-HD0002	Upper Looper	23	G-25
CCT-BF0001	Lower Knife Holder	33	K-16	CGA-BK0001	Needle Guard (Rear)	69	O8-48	CGA-HD0002	Upper Looper	87	O11-79
CCT-BF0012	Lower Knife Holder	61	O7-71	CGA-BK0001	Needle Guard (Rear)	73	O9-64	CGA-HD0002	Upper Looper	89	O11-79
CCT-BF0012	Lower Knife Holder	67	O8-66	CGA-BK0001	Needle Guard (Rear)	79	O10-79	CGA-HD0002	Upper Looper	93	O12-35
CCT-BF0012	Lower Knife Holder	69	O8-66	CGA-BK0001	Needle Guard (Rear)	87	O11-73	CGA-HD0002	Upper Looper	95	O12-35
CCT-BF0012	Lower Knife Holder	75	O9-85	CGA-BK0001	Needle Guard (Rear)	89	O11-73	CGA-HD0005	Looper	27	I-24
CCT-BF0012	Lower Knife Holder	81	O10-101	CGA-BK0002	Needle Guard (Front)	51	O5-40	CGA-HD0006	Upper Looper	49	O4-7
CCT-BJ0001	Lower Knife Holder Guide	33	K-18	CGA-BK0002	Needle Guard (Front)	55	O6-40	CGA-HG0001	Needle Guard (Front)	21	F-35
CCT-BJ0002	Plate	33	K-21	CGA-BK0002	Needle Guard (Front)	61	O7-51	CGA-HG0002	Needle Guard (Rear)	21	F-37
CCT-BL0002	Upper Knife Clamp	51	O5-55	CGA-BK0002	Needle Guard (Front)	67	O8-46	CGA-HG0002	Needle Guard (Rear)	51	O5-36
CCT-BL0002	Upper Knife Clamp	55	O6-54	CGA-BK0002	Needle Guard (Front)	69	O8-46	CGA-HG0002	Needle Guard (Rear)	55	O6-36
CCT-BL0002	Upper Knife Clamp	61	O7-68	CGA-BK0002	Needle Guard (Front)	73	O9-62	CGA-HG0002	Needle Guard (Rear)	61	O7-47
CCT-BL0002	Upper Knife Clamp	67	O8-63	CGA-BK0002	Needle Guard (Front)	79	O10-77	CGA-HG0002	Needle Guard (Rear)	67	O8-42
CCT-BL0002	Upper Knife Clamp	69	O8-63	CGA-BK0002	Needle Guard (Front)	87	O11-71	CGA-HG0002	Needle Guard (Rear)	69	O8-42
CCT-BL0002	Upper Knife Clamp	75	O9-83	CGA-BK0002	Needle Guard (Front)	89	O11-71	CGA-HG0002	Needle Guard (Rear)	73	O9-58
CCT-BL0002	Upper Knife Clamp	87	O11-88	CGA-BK0003	Needle Guard (Front)	51	O5-34	CGA-HG0002	Needle Guard (Rear)	79	O10-73
CCT-BL0002	Upper Knife Clamp	89	O11-88	CGA-BK0003	Needle Guard (Front)	55	O6-34	CGA-HG0002	Needle Guard (Rear)	87	O11-67
CCT-CB0001	Crank	33	K-3	CGA-BK0003	Needle Guard (Front)	61	O7-45	CGA-HG0002	Needle Guard (Rear)	89	O11-67
CCT-CB0003	Crank	55	O6-53	CGA-BK0003	Needle Guard (Front)	67	O8-40	CL-000320	Collar	107	Q-83
CCT-CB0003	Crank	61	O7-67	CGA-BK0003	Needle Guard (Front)	69	O8-40	CL-000322	Collar	107	Q-70
CCT-CB0003	Crank	67	O8-62	CGA-BK0003	Needle Guard (Front)	73	O9-56	CL-000332	Collar	105	Q-11
CCT-CB0003	Crank	69	O8-62	CGA-BK0003	Needle Guard (Front)	79	O10-71	CL-000333	Collar	105	Q-14
CCT-CB0003	Crank	75	O9-81	CGA-BK0003	Needle Guard (Front)	87	O11-65	CL-000334	Collar	79	O10-45
CCT-CB0003	Crank	81	O10-92	CGA-BK0003	Needle Guard (Front)	89	O11-65	CL-000334	Collar	85	O11-44
CCT-CB0003	Crank	87	O11-86	CGA-BK0004	Upper Looper	43	O1-18	CL-000334	Collar	93	O12-19
CCT-CB0003	Crank	89	O11-86	CGA-BK0004	Upper Looper	45	O2-18	CL-000334	Collar	95	O12-19
CCT-CC0001	Connection	33	K-1	CGA-BK0004	Upper Looper	55	O6-47	CLA-BB0001	LED Lamp Bracket	101	O13-55
CCT-KZ0001	Upper Knife Lever	33	K-9	CGA-GB0001	Main Feed Dog	31	J-60	CLA-BD0001	LED Body	101	O13-54-1-1
CCT-NA0001	Plate Knife	33	K-14	CGA-GB0002	Auxiliary Feed Dog	31	J-61	CLA-LA0001	LED Cover	101	O13-54-4
CCT-NA0001	Plate Knife	87	O11-89	CGA-GB0002	Auxiliary Feed Dog	87	O11-84	CLB-BB0001	Bracket	23	G-32
CCT-NA0001	Plate Knife	89	O11-89	CGA-GB0002	Auxiliary Feed Dog	89	O11-84	CLB-BB0002	Oil Guide	37	M-4
CCT-NB0001	Lower Knife (Thick)	33	K-23	CGA-GB0003	Differential Feed Dog	31	J-65	CLB-BD0001	Pump Housing	37	M-1-1
CCT-NB0001	Lower Knife (Thick)	87	O11-91	CGA-GB0024	Main Feed Dog	51	O5-51	CLB-BD0003	Pump Housing	81	O10-127-1
CCT-NB0001	Lower Knife (Thick)	89	O11-91	CGA-GB0024	Main Feed Dog	55	O6-51	CLB-BD0003	Pump Housing	91	O11-109-1
CFA-BF0001	Holder	29	J-15	CGA-GB0024	Main Feed Dog	87	O11-83	CLB-BD0003	Pump Housing	97	O12-54-1
CFA-BJ0001	Regulator Plate	29	J-18	CGA-GB0024	Main Feed Dog	89	O11-83	CLB-BF0014	Oil Shield Cover	99	O13-41
CFA-CA0001	Link	29	J-8	CGA-GB0025	Differential Feed Dog	55	O6-52	CLB-BG0018	Clamp	13	B-89
CFA-CB0001	Lever	29	J-11	CGA-GB0025	Differential Feed Dog	87	O11-85	CLB-BG0018	Clamp	37	M-12
CFA-CC0001	Connection	29	J-1-1	CGA-GB0025	Differential Feed Dog	89	O11-85	CLB-BG0018	Clamp	37	M-16
CFA-CD0001	Stopper	29	J-24	CGA-GB0028	Differential Feed Dog	51	O5-53	CLB-BG0018	Clamp	37	M-20
CFA-CM0001	Lever	29	J-13	CGA-GB0029	Auxiliary Feed Dog	51	O5-52	CLB-BG0052	Oil Shield Plate Holder	99	O13-44
CFA-CR0001	Adjusting Bar	29	J-27	CGA-GB0030	Differential Feed Dog	45	O2-20	CLB-BH0012	Oil Hose Holder	99	O13-32
CFA-CS0001	Ratchet	29	J-1-14	CGA-GB0031	Main Feed Dog	45	O2-19	CLB-BJ0002	Filter	23	G-13
CFA-DC0001	Eccentric Cam	29	J-1-11	CGA-GB0185	Main Feed Dog	67	O8-59	CLB-BJ0003	Oil Pump Cover	37	M-1-6
CFA-DC0002	Eccentric Plate	29	J-1-5	CGA-GB0185	Main Feed Dog	69	O8-59	CLB-BJ0029	Oil Splasher	99	O13-42
CFA-DC0003	Guide(Feed Eccentric)	29	J-1-6	CGA-GB0185	Main Feed Dog	73	O9-78	CLB-BJ0031	Plate	31	J-77
CFA-DC0004	Regulator	29	J-1-9	CGA-GB0185	Main Feed Dog	81	O10-89	CLB-BJ0031	Plate	31	J-77
CFA-FG0001	Gasket	29	J-3	CGA-GB0186	Auxiliary Feed Dog	61	O7-65	CLB-BK0008	Oil Adjusting Block	99	O13-33
CFR-AC0001	Frame	99	O13-3	CGA-GB0186	Auxiliary Feed Dog	67	O8-60	CLB-BK0011	Oil Adjusting Block	99	O13-33
CFR-BB0001	Bracket	9	A-6-1	CGA-GB0186	Auxiliary Feed Dog	69	O8-60	CLB-BL0001	Clamp	37	M-1-10

Index

Parts No.	Name of Parts	Page	Ref.No.	Parts No.	Name of Parts	Page	Ref.No.	Parts No.	Name of Parts	Page	Ref.No.
CLB-CT0001	Rotor (Outside)	37	M-1-5	CLF-CR0001	Main Feed Bar	31	J-58	CMB-JB0007	Silicone Oil Reservoir(Lower)	71	O9-9
CLB-FZ0009	Oil Adjusting Rubber	99	O13-37	CLF-CR0002	Defferential Feed Bar	31	J-64	CMB-JB0007	Silicone Oil Reservoir(Lower)	77	O10-9
CLB-JB0001	Tank	37	M-3	CLF-FB0001	Gasket	31	J-48	CMB-JL0002	Felt	13	B-80
CLB-JD0017	Oil Wick	13	B-87	CLF-KC0001	Shaft	29	J-33	CMB-JL0002	Felt	93	O12-4
CLB-JD0017	Oil Wick	37	M-34-3	CLL-BF0001	Lower Looper Holder Assy.	25	H-16	CMB-JL0002	Felt	95	O12-4
CLB-JD0017	Oil Wick	37	M-36-2	CLL-CB0001	Crank	25	H-6	CMB-JL0003	Oil Felt	13	B-93
CLB-JD0017	Oil Wick	75	O9-97	CLL-CB0002	Crank	51	O5-48	CMB-JL0003	Oil Felt	71	O9-10
CLB-JF0002	Pipe	37	M-34-1	CLL-CB0002	Crank	55	O6-48	CMB-JL0003	Oil Felt	77	O10-10
CLB-JF0003	Pipe Assy	37	M-36-1	CLL-CB0002	Crank	61	O7-61	CMB-JL0003	Oil Felt	85	O11-10
CLB-JG0008	Tube	13	B-88	CLL-CB0002	Crank	67	O8-56	CMB-LA0044	Top Cover	11	B-1
CLB-JG0008	Tube	37	M-13	CLL-CB0002	Crank	73	O9-75	CMB-LA0045	Face Cover	11	B-6
CLB-JG0008	Tube	37	M-21	CLL-CB0002	Crank	81	O10-86	CMB-LA0049	Bed Cover Plate Ass'y	13	B-67
CLB-JG0008	TUBE	37	M-17	CLL-CB0002	Crank	87	O11-80	CMB-LA0052	Cover	11	B-27
CLB-JG0013	Hose	101	O13-66	CLL-CB0002	Crank	89	O11-80	CMB-LA0053	Fan Cover	11	B-9
CLB-JH0001	Oil Distributor	37	M-22-1	CLP-BF0009	Looper Bracket	27	I-26	CMB-LA0054	Front Cover (Left)	11	B-25
CLB-JJ0002	Oil Sight Window	11	B-4	CLP-BF0010	Looper Slide Holder	27	I-14	CMB-LA0055	Front Cover (Right)	11	B-11
CLB-JJ0002	Oil Window	99	O13-8	CLP-BJ0018	Looper Bracket Spacer	27	I-28	CMB-LA0056	Cover Plate	13	B-70
CLB-JL0019	Felt	21	F-19	CLP-CB0001	Looper Driving Crank	27	I-16	CMB-LA0057	Fabric Guide	13	B-59
CLB-JL0019	Felt	101	O13-71	CLP-CB0002	Looper Slide Crank	27	I-3	CMB-LA0058	Plate	11	B-53
CLB-JL0020	Felt	23	G-22	CLP-CC0003	Looper Connection Rod	27	I-1	CMB-LA0063	Belt Cover Assy.	41	N-20
CLB-JL0021	Felt	23	G-31	CLP-CD0002	Looper Slide	27	I-7	CMB-LA0064	Cover	13	B-79
CLB-JL0104	Oil Return Felt	99	O13-43	CLP-DC0002	Looper Cam	27	I-49-1	CMB-LA0065	Cover	13	B-83
CLB-JL0113	Felt	53	O5-58	CLP-KC0007	Looper Shaft	27	I-22	CMB-LA0066	Cover	13	B-85
CLB-JL0113	Felt	55	O6-57	CLP-KC0008	Looper Adjustment Shaft	27	I-11	CMB-LA0171	Motor Cover	99	O13-11
CLB-JL0113	FELT	61	O7-82	CLP-KC0009	Slide Shaft	27	I-13	CMB-LA0172	Safety Plate	101	O13-58
CLB-JL0113	Felt	67	O8-77	CM-000006	Eccentric	105	Q-47	CMB-LA0173	Face Plate	11	B-6
CLB-JL0113	Felt	69	O8-77	CMB-BB0038	Bracket	13	B-64	CMB-LA0173	Face Plate	99	O13-1
CLB-JL0113	Felt	77	O10-7	CMB-BB0039	Latch	11	B-17	CMB-LA0174	Front Cover(R)	99	O13-13
CLB-JM0001	Filter	37	M-1-8	CMB-BB0040	Hinge	11	B-12	CMB-LA0175	Front Cover(L)	99	O13-14
CLB-JM0002	Filter	37	M-1-9	CMB-BB0041	Latch	11	B-51	CMB-LA0176	Top Cover	99	O13-4
CLB-JM0003	Filter Element	37	M-6	CMB-BB0042	Bracket	13	B-58	CMB-LA0177	Top Cover Gasket	99	O13-5
CLB-JN0002	Oil Gauge	101	O13-47	CMB-BB0079	Safety Plate Bracket	101	O13-57	CMB-LD0022	Model Mark	101	O13-65
CLB-JN0002	Oil Lever Gauge	37	M-25	CMB-BJ0022	Eye Guard	13	B-61	CMB-LD0023	Series Sticker	101	O13-68
CLB-JP0002	Joint	37	M-10	CMB-BJ0023	Latch	11	B-21	CMB-LD0045	Threading diagram 1	51	O5-2
CLB-JP0002	Joint	37	M-14	CMB-CM0001	Lever	11	B-55	CMB-LD0045	Threading diagram 1	55	O6-2
CLB-JP0002	Joint	37	M-18	CMB-FC0025	Gasket	11	B-3	CMB-LD0046	Threading Diagram 2	11	B-37
CLB-JP0002	Nipple	99	O13-30	CMB-FD0009	Cushion Rubber	11	B-44	CMB-LD0046	Threading diagram 2	51	O5-3
CLB-JP0028	Nipple	101	O13-48	CMB-FD0009	Cushion Rubber	11	B-50	CMB-LD0046	Threading diagram 2	55	O6-3
CLB-JP0029	Joint	83	O10-145	CMB-FD0009	Cushion Rubber	21	F-32	CMB-LD0046	Threading Diagram 2	59	O7-3
CLB-JP0029	Joint	91	O11-127	CMB-FD0009	Cushion Rubber	41	N-21	CMB-LD0046	Threading Diagram 2	65	O8-3
CLB-JP0029	Joint	97	O12-72	CMB-FD0009	Cushion Rubber	51	O5-31	CMB-LD0046	Threading Diagram 2	71	O9-5
CLB-JP0029	Nipple	101	O13-67	CMB-FD0009	Cushion Rubber	55	O6-31	CMB-LD0046	Threading Diagram 2	77	O10-5
CLB-JP0030	Nipple	101	O13-46	CMB-FD0009	Cushion Rubber	61	O7-42	CMB-LD0058	Threading diagram 1	43	O1-1
CLB-LA0001	Cover	37	M-7	CMB-FD0009	Cushion Rubber	67	O8-37	CMB-LD0058	Threading Diagram 1	45	O2-1
CLB-LA0003	Cover	83	O10-133	CMB-FD0009	Cushion Rubber	69	O8-37	CMB-LD0059	Caution Label	11	B-33
CLB-LA0003	Cover	91	O11-115	CMB-FD0009	Cushion Rubber	73	O9-53	CMB-LD0060	Caution Label	11	B-32
CLB-LA0003	Cover	97	O12-60	CMB-FD0009	Cushion Rubber	79	O10-68	CMB-LD0061	Label	11	B-34
CLF-BB0001	Feed Bar Guide(Left)	31	J-70	CMB-FD0009	Cushion Rubber	87	O11-62	CMB-LD0087	Threading Diagram 1	11	B-31
CLF-BB0002	Feed Bar Guide(Right)	31	J-68	CMB-FD0009	Cushion Rubber	89	O11-62	CNB-BB0007	Bracket	51	O5-44
CLF-BB0003	Guide(Feed Bar Oil Seal)	31	J-72	CMB-FG0001	Gasket	13	B-69	CNB-BB0007	Bracket	55	O6-44
CLF-BB0003	Guide(Feed Bar Oil Seal)	31	J-72	CMB-HK0016	Pipe	9	A-3	CNB-BB0007	Bracket	61	O7-55
CLF-CA0001	LINK	31	J-54	CMB-HK0017	Thread Guide	17	D-3	CNB-BB0007	Bracket	67	O8-50
CLF-CA0001	Looper Connection Link	27	I-18	CMB-HK0018	Thread Guide	13	B-81	CNB-BB0007	Bracket	69	O8-50
CLF-CB0001	Crank Front	29	J-37-1	CMB-HK0018	Thread Guide	93	O12-5	CNB-BB0007	Bracket	73	O9-66
CLF-CB0002	Crank Rear	29	J-37-2	CMB-HK0018	Thread Guide	95	O12-5	CNB-BB0007	Bracket	79	O10-81
CLF-CB0003	Crank	29	J-37-3	CMB-JB0002	Silicone Oil Reservoir (Uppper)	13	B-78	CNB-BB0007	Bracket	87	O11-75
CLF-CB0004	Crank	31	J-41	CMB-JB0003	Silicone Oil Reservoir (Lower)	13	B-84	CNB-BB0007	Bracket	89	O11-75
CLF-CD0001	Block	29	J-40	CMB-JB0007	Silicone Oil Reservoir (Lower)	53	O5-60	CNB-BF0002	Holder	21	F-20
CLF-CD0002	Block	31	J-67	CMB-JB0007	Silicone Oil Reservoir (Lower)	57	O6-59	CNB-BJ0001	Bracket (Font)	21	F-30
CLF-CD0003	Block	31	J-51	CMB-JB0007	Silicone Oil Reservoir (Lower)	67	O8-79	CNB-BJ0001	Bracket (Front)	51	O5-29
CLF-CH0001	Pin	31	J-46	CMB-JB0007	Silicone Oil Reservoir (Lower)	69	O8-79	CNB-BJ0001	Bracket (Front)	55	O6-29
CLF-CJ0001	Pin	31	J-43	CMB-JB0007	SILICONE OIL RESERVOIR(LOWER)	61	O7-84	CNB-BJ0001	Bracket (Front)	61	O7-40

Index

Parts No.	Name of Parts	Page	Ref.No.	Parts No.	Name of Parts	Page	Ref.No.	Parts No.	Name of Parts	Page	Ref.No.
CNB-BJ0001	Bracket (Front)	67	O8-35	CTA-BD0004	Retainer For Thread Tension Spring Cap	71	O9-18-4	CTA-HM0004	Thread Tension Post	71	O9-18-7
CNB-BJ0001	Bracket (Front)	69	O8-35	CTA-BD0004	Retainer For Thread Tension Spring Cap	77	O10-27-4	CTA-HM0004	Thread Tension Post	77	O10-27-7
CNB-BJ0001	Bracket (Front)	73	O9-51	CTA-BD0004	Retainer For Thread Tension Spring Cap	77	O10-28-4	CTA-HM0004	Thread Tension Post	77	O10-28-7
CNB-BJ0001	Bracket (Front)	79	O10-66	CTA-BD0004	Retainer For Thread Tension Spring Cap	77	O10-29-4	CTA-HM0004	Thread Tension Post	77	O10-29-7
CNB-BJ0001	Bracket (Front)	87	O11-60	CTA-BD0004	Retainer for Thread Tension Spring Cap	59	O7-11-4	CTA-JL0001	Felt for Thread Tension Device	59	O7-11-6
CNB-BJ0001	Bracket (Front)	89	O11-60	CTA-BD0004	Retainer for Thread Tension Spring Cap	59	O7-10-4	CTA-JL0001	Felt for Thread Tension Device	17	D-1-6
CNB-BJ0002	Bracket (Rear)	21	F-33	CTA-BD0004	Retainer for Thread Tension Spring Cap	59	O7-12-4	CTA-JL0001	Felt for Thread Tension Device	17	D-2-6
CNB-BJ0002	Bracket (Rear)	51	O5-32	CTA-BD0004	Retainer for Thread Tension Spring Cap	65	O8-10-4	CTA-JL0001	Felt for Thread Tension Device	59	O7-10-6
CNB-BJ0002	Bracket (Rear)	55	O6-32	CTA-BD0004	Retainer for Thread Tension Spring Cap	65	O8-12-4	CTA-JL0001	Felt for Thread Tension Device	59	O7-12-6
CNB-BJ0002	Bracket (Rear)	61	O7-43	CTA-BD0004	Spring Cover	99	O13-17-4	CTA-JL0001	Felt for Thread Tension Device	65	O8-10-6
CNB-BJ0002	Bracket (Rear)	67	O8-38	CTA-BD0004	Spring Cover	99	O13-18-4	CTA-JL0001	Felt for Thread Tension Device	65	O8-12-6
CNB-BJ0002	Bracket (Rear)	69	O8-38	CTA-BD0004	Thread Tension Spring-Needle	65	O8-11-3	CTA-JL0001	Felt For Thread Tension Device	71	O9-16-6
CNB-BJ0002	Bracket (Rear)	73	O9-54	CTA-BF0002	Thread Tension Nut	27	I-42-1	CTA-JL0001	Felt For Thread Tension Device	71	O9-17-6
CNB-BJ0002	Bracket (Rear)	79	O10-69	CTA-BJ0029	Tension Disc	27	I-40	CTA-JL0001	Felt For Thread Tension Device	71	O9-18-6
CNB-BJ0002	Bracket (Rear)	87	O11-63	CTA-BN0003	Spring Stopper	99	O13-17-2	CTA-JL0001	Felt For Thread Tension Device	77	O10-27-6
CNB-BJ0002	Bracket (Rear)	89	O11-63	CTA-BN0003	Spring Stopper	99	O13-18-2	CTA-JL0001	Felt For Thread Tension Device	77	O10-28-6
CNB-BJ0012	Thread Guide	51	O5-24	CTA-BN0003	Stopper for Tension Spring	17	D-1-2	CTA-JL0001	Felt For Thread Tension Device	77	O10-29-6
CNB-BJ0012	Thread Guide	55	O6-24	CTA-BN0003	Stopper for Tension Spring	17	D-2-2	CTA-JL0001	Tension Disc	65	O8-11-5
CNB-CB0001	Crank	21	F-5	CTA-BN0003	Stopper for Tension Spring	59	O7-10-2	CTA-JL0001	Thread Guide Disk Felt	99	O13-17-6
CNB-CB0002	Lever	21	F-12	CTA-BN0003	Stopper for Tension Spring	59	O7-11-2	CTA-JL0001	Thread Guide Disk Felt	99	O13-18-6
CNB-CC0001	Connection	21	F-1	CTA-BN0003	Stopper for Tension Spring	59	O7-12-2	CTA-KF0003	Thread Tension Shaft	27	I-39
CNB-HK0005	Thread Guide	21	F-25	CTA-BN0003	Stopper for Tension Spring	65	O8-10-2	CTG-BB0001	Thread Guide Bracket-Looper	19	E-13
CNB-KA0004	Needle Bar	21	F-16-2	CTA-BN0003	Stopper for Tension Spring	65	O8-11-2	CTG-BB0002	Thread Retainer Bracket	19	E-7
CNB-KA0004	Needle Bar	101	O13-70	CTA-BN0003	Stopper for Tension Spring	65	O8-12-2	CTG-BB0003	Thread Guide Holder	51	O5-13
CNB-KC0001	Shaft	21	F-7	CTA-BN0003	Stopper For Tension Spring	71	O9-16-2	CTG-BB0003	Thread Guide Holder	55	O6-13
CPB-BB0002	PRESSER ARM	61	O7-81	CTA-BN0003	Stopper For Tension Spring	71	O9-17-2	CTG-BB0003	Thread Guide Holder	59	O7-22
CPB-BB0002	Presser Arm	69	O8-76	CTA-BN0003	Stopper For Tension Spring	71	O9-18-2	CTG-BB0003	Thread Guide Holder	65	O8-17
CPB-BB0002	Presser Arm	35	L-16	CTA-BN0003	Stopper For Tension Spring	77	O10-27-2	CTG-BB0003	Thread Guide Holder	71	O9-23
CPB-BB0002	Presser Arm	67	O8-76	CTA-BN0003	Stopper For Tension Spring	77	O10-28-2	CTG-BB0003	Thread Guide Holder	79	O10-34
CPB-BJ0003	Stopper	35	L-26	CTA-HK0001	Tension Guide	17	D-6	CTG-BF0001	Thread Guide Holder	19	E-3
CPB-CM0004	Lever	35	L-23	CTA-HK0001	Tension Guide	43	O1-5	CTG-BG0001	Thread Guide Holder	27	I-35
CPB-KZ0001	Shaft	35	L-15	CTA-HK0001	Tension Guide	45	O2-5	CTG-BG0002	Thread Guide Plate Holder	27	I-51
CPM-BB0003	Stopper	35	L-4	CTA-HK0001	Tension Guide	59	O7-13	CTG-BJ0001	Thread Guide	71	O9-21-1
CPM-BH0001	Link	35	L-8	CTA-HK0001	Thread Guide Plate	99	O13-19	CTG-BJ0001	Thread Guide	79	O10-32-1
CPM-CB0002	Crank	35	L-10	CTA-HL0002	Retainer for Thread Tension Spring Cap	65	O8-11-4	CTG-BJ0002	Thread Guide	71	O9-25-1
CPM-CM0006	Lever	35	L-1	CTA-HL0002	Tension Disc	17	D-1-5	CTG-BJ0002	Thread Guide	79	O10-36-1
CPM-CM0007	Lever	35	L-9	CTA-HL0002	Tension Disc	17	D-2-5	CTG-BJ0003	Thread Guide	51	O5-17
CST-BA0002	Rest Board	41	N-22	CTA-HL0002	Tension Disc	59	O7-10-5	CTG-BJ0003	Thread Guide	55	O6-17
CST-BA0002	Rest Board	111	R-1	CTA-HL0002	Tension Disc	59	O7-11-5	CTG-BJ0003	Thread Guide	65	O8-21
CST-BB0015	Waste Chute(Top)	41	N-30	CTA-HL0002	Tension Disc	59	O7-12-5	CTG-BJ0004	Thread Guide	51	O5-19
CST-BB0015	Waste Chute(Top)	111	R-22	CTA-HL0002	Tension Disc	65	O8-10-5	CTG-BJ0004	Thread Guide	55	O6-19
CST-BB0016	Waste Chute(Lower)	41	N-31	CTA-HL0002	Tension Disc	65	O8-12-5	CTG-BJ0004	Thread Guide	59	O7-28
CST-BB0016	Waste Chute(Lower)	111	R-23	CTA-HL0002	Tension Disc	71	O9-16-5	CTG-BJ0004	Thread Guide	65	O8-23
CST-BB0017	Bracket	41	N-33	CTA-HL0002	Tension Disc	71	O9-17-5	CTG-BJ0004	Thread Guide	79	O10-40
CST-BB0017	Bracket	111	R-26	CTA-HL0002	Tension Disc	71	O9-18-5	CTG-BJ0005	Thread Guide	53	O5-59
CST-BF0001	Holder for Thread Guide Bar	41	N-1-6	CTA-HL0002	Tension Disc	77	O10-27-5	CTG-BJ0005	Thread Guide	57	O6-58
CST-BF0002	Holder for Thread Guide Sub-Bar	41	N-1-1	CTA-HL0002	Tension Disc	77	O10-28-5	CTG-BJ0005	THREAD GUIDE	61	O7-83
CST-BH0001	Thread Guide Sub-Bar	41	N-1-5	CTA-HL0002	Tension Disc	77	O10-29-5	CTG-BJ0005	Thread Guide	67	O8-78
CST-BH0002	Thread Guide Bar	41	N-1-9	CTA-HL0002	Thread Guide Disk	99	O13-17-5	CTG-BJ0005	Thread Guide	69	O8-78
CST-FB0001	Washer	37	M-28	CTA-HL0002	Thread Guide Disk	99	O13-18-5	CTG-BJ0005	Thread Guide	77	O10-8
CST-FB0003	Spacer	41	N-25	CTA-HM0004	Felt for Thread Tension Device	65	O8-11-6	CTG-BJ0006	Looper Thread Guide A	27	I-43
CST-FD0013	Cushion Rubber	41	N-23	CTA-HM0004	Thread Tension Adjusting Shaft	99	O13-17-7	CTG-BJ0007	Looper Thread Guide D	27	I-52
CST-FD0013	Cushion Rubber	111	R-2	CTA-HM0004	Thread Tension Adjusting Shaft	99	O13-18-7	CTG-BJ0008	Looper Thread Guide B	27	I-45
CST-FG0001	Rubber Ling	37	M-31	CTA-HM0004	Thread Tension Post	17	D-1-7	CTG-BJ0009	Looper Thread Guide C	27	I-47
CST-JA0007	Oil Reservoir Assy	37	M-26	CTA-HM0004	Thread Tension Post	17	D-2-7	CTG-BJ0010	Looper Thread Guide	27	I-36
CTA-BB0001	Thread Tension Device (Assembly) Bracket	43	O1-7	CTA-HM0004	Thread Tension Post	59	O7-10-7	CTG-BK0001	Thread Guide Bracket-Needle	51	O5-9
CTA-BB0001	Thread Tension Device(Assembly) Bracket	17	D-5	CTA-HM0004	Thread Tension Post	59	O7-11-7	CTG-BK0001	Thread Guide Bracket-Needle	55	O6-9
CTA-BB0011	Thread Tension Adjusting Assembly Bracket	99	O13-20	CTA-HM0004	Thread Tension Post	59	O7-12-7	CTG-BK0001	Thread Guide Bracket-Needle	59	O7-18
CTA-BD0004	Retainer for Thread Tension Spring Cap	17	D-1-4	CTA-HM0004	Thread Tension Post	65	O8-10-7	CTG-BK0001	Thread Guide Bracket-Needle	65	O8-13
CTA-BD0004	Retainer for Thread Tension Spring Cap	17	D-2-4	CTA-HM0004	Thread Tension Post	65	O8-12-7	CTG-BK0001	Thread Guide Bracket-Needle	71	O9-19
CTA-BD0004	Retainer For Thread Tension Spring Cap	71	O9-16-4	CTA-HM0004	Thread Tension Post	71	O9-16-7	CTG-BK0001	Thread Guide Bracket-Needle	77	O10-30
CTA-BD0004	Retainer For Thread Tension Spring Cap	71	O9-17-4	CTA-HM0004	Thread Tension Post	71	O9-17-7	CTG-BQ0001	Thread Guide Bar B	27	I-34

Index

Parts No.	Name of Parts	Page	Ref.No.	Parts No.	Name of Parts	Page	Ref.No.	Parts No.	Name of Parts	Page	Ref.No.
CTG-BQ0002	Thread Guide Bar A	27	I-32	DBS-DA0055	Bushing	27	I-31	DPK-CB0009	Plug	21	F-22
CTG-HK0001	Thread Guide	19	E-1-1	DBS-DA0055	Rear Bush for Knife Driving Shaft	25	H-20	DPK-CB0016	Plug	11	B-5
CTG-HK0002	Thread Guide	19	E-5	DBS-DA0055	Rear Bush for Knife Driving Shaft	31	J-76	DPK-CB0016	Rubber Cap	99	O13-7
CTG-HK0003	Thread Guide	19	E-14	DBS-DA0055	Rear Bush for Knife Driving Shaft	33	K-28	DPK-CB0017	PLUG	23	G-12
CTG-HK0004	Thread Guide	19	E-21	DBS-DA0056	Bushing	27	I-30	DPK-CB0029	Rubber Cap	99	O13-9
CTG-HK0005	Thread Guide	19	E-22	DBS-DA0056	Front Bush for Upper Looper Thread Take Up Shaft	107	Q-78	DPL-AA0004	Machine Pulley	15	C-20
CTG-HK0006	Thread Retainer	19	E-8	DBS-DA0056	Front Bush for Upper Looper Thread Take Up Shaft	23	G-35	DPN-AA0018	Pin	9	A-4
CTG-HK0007	Thread Guide	43	O1-9	DBS-DA0056	Front Bush for Upper Looper Thread Take Up Shaft	25	H-19	DPN-AA0019	Pin	21	F-3
CTG-HK0007	Thread Guide	45	O2-8	DBS-DA0056	Front Bush for Upper Looper Thread Take Up Shaft	31	J-75	DPN-AA0020	Shaft Assy.	21	F-14
CTG-HK0009	Thread Guide	43	O1-13	DBS-DA0057	Rear Bush for Upper Looper Thread Take Up Shaft	23	G-36	DPN-AA0021	Pin	29	J-1-2
CTG-HK0009	Thread Guide	45	O2-12	DBS-DA0058	Bush for Presser Foot Shaft	35	L-13	DPN-AA0021	Pin	33	K-5
CTH-BJ0001	Needle Thread Take Up	51	O5-21	DBS-DA0240	Bushing	99	O13-22	DPN-AA0022	Pin	33	K-11
CTH-BJ0001	Needle Thread Take Up	55	O6-21	DBS-DA0242	Bushing	101	O13-54-1-2	DPN-AA0023	Pin ASSY.	23	G-18
CTH-BJ0001	Needle Thread Take Up	79	O10-42	DBS-DA0243	Bushing	101	O13-50	DPN-AA0024	Pin	11	B-14
CTH-BJ0002	Needle Thread Take Up	43	O1-10	DBS-DB0014	Bushing	11	B-39	DPN-AA0025	Pin	35	L-17
CTH-BJ0002	Needle Thread Take Up	45	O2-9	DCL-AA0018	Collar	21	F-8	DPN-AD0028	Pin	29	J-31
CTH-HJ0005	Needle Thread Take Up	19	E-12	DCL-AA0020	Collar	31	J-52	DPN-BC0003	Pin	9	A-6-2
CTH-HJ0006	Looper Thread Take Up	19	E-23	DCL-AA0021	Collar	33	K-7	DPN-BC0004	Pin	15	C-4
CTH-HK0001	Looper Thread Take Up	19	E-17	DCL-AA0084	Looper Cam Collar	27	I-49-2	DPN-BC0005	Push Button	29	J-2
CTH-HK0002	Thread Guide	19	E-19	DCL-BA0005	Spacer	15	C-24	DPN-BC0008	Pin	19	E-1-2
CTT-CB0003	Crank	51	O5-54	DCL-BA0014	Looper Cam Spacer	27	I-49-3	DPN-BC0008	Pin	71	O9-21-2
CUL-BA0001	Upper Looper Holder Base	23	G-21-3	DCL-BB0009	Spacer	29	J-20	DPN-BC0008	Pin	71	O9-25-2
CUL-BF0001	Upper Looper Holder	23	G-21-1	DCL-BB0010	Spacer	23	G-14	DPN-BC0008	Pin	79	O10-32-2
CUL-BF0001	Upper Looper Holder	61	O7-59-1	DCL-BB0026	Spacer	43	O1-17	DPN-BC0008	Pin	79	O10-36-2
CUL-BF0001	Upper Looper Holder	81	O10-84-1	DCL-BB0026	Spacer	45	O2-17	DPN-BC0008	Pin	85	O11-33-2
CUL-BF0001	Upper Looper Holder	67	O8-54-1	DCL-BB0026	Spacer	51	O5-47	DPN-BC0008	Pin	85	O11-37-2
CUL-BF0001	Upper Looper Holder	69	O8-54-1	DCL-BB0026	Spacer	55	O6-46	DPN-BC0044	Pin	51	O5-5
CUL-BJ0001	Cover	23	G-27	DCL-BB0026	Spacer	61	O7-57	DPN-BC0044	Pin	55	O6-5
CUL-BJ0002	Guide	23	G-4	DCL-BB0026	Spacer	67	O8-52	DPN-BC0044	Pin	65	O8-6
CUL-BJ0002	Guide	25	H-4	DCL-BB0026	Spacer	69	O8-52	DPN-BC0044	Pin	71	O9-12
CUL-BK0001	Upper Looper Holder Block	23	G-21-2	DCL-BB0026	Spacer	73	O9-70	DPN-BC0044	Pin	77	O10-23
CUL-BK0001	Upper Looper Holder Block	61	O7-59-2	DCL-BB0026	Spacer	81	O10-83	DPN-BD0044	Pin	59	O7-6
CUL-BK0001	Upper Looper Holder Block	67	O8-54-2	DCL-BB0026	Spacer	87	O11-78	DSC-AA0014	Bolt	21	F-13
CUL-BK0001	Upper Looper Holder Block	69	O8-54-2	DCL-BB0026	Spacer	89	O11-78	DSC-AA0014	Bolt	23	G-17
CUL-BK0001	Upper Looper Holder Block	73	O9-72-2	DCL-BB0026	Spacer	93	O12-34	DSC-AA0014	Bolt	25	H-15
CUL-BK0001	Upper Looper Holder Block	81	O10-84-2	DCL-BB0026	Spacer	95	O12-34	DSC-AA0014	Bolt	79	O10-50
CUL-CB0001	Crank	23	G-6	DGR-AA0019	Gear	15	C-9-2	DSC-AA0014	Bolt	85	O11-49
CUL-CB0002	Lever	23	G-16	DGR-AG0001	Worm	37	M-32	DSC-AA0014	Bolt	93	O12-24
CUL-CB0003	Crank	43	O1-16	DGR-AH0001	Worm Wheel	37	M-1-3	DSC-AA0014	Bolt	95	O12-24
CUL-CB0003	Crank	45	O2-16	DPK-AH0001	Oil Seal	23	G-15	DSC-AA0015	Screw	33	K-13
CUL-CB0003	Crank	51	O5-46	DPK-AH0001	Oil Seal	25	H-13	DSC-AA0015	Screw	33	K-17
CUL-CB0003	Crank	87	O11-77	DPK-AZ0001	Looper Oil Seal	27	I-23	DSC-AA0016	Bolt	23	G-10
CUL-CB0003	Crank	89	O11-77	DPK-AZ0001	Oil Seal	23	G-34	DSC-AA0016	Bolt	25	H-10
CUL-CB0003	Crank	93	O12-33	DPK-AZ0001	Oil Seal	33	K-26	DSC-AA0016	Bolt	33	K-25
CUL-CB0003	Crank	95	O12-33	DPK-AZ0002	Oil Seal	15	C-14	DSC-AA0017	Bolt	25	H-17
CUL-CC0001	Connection	23	G-1	DPK-AZ0003	Oil Seal	31	J-73	DSC-AA0017	Screw	27	I-27
CUL-CC0001	Connection	25	H-1	DPK-BA0001	O Ring	15	C-8	DSC-AA0018	Bolt	105	Q-3
CUL-KC0001	Shaft	23	G-8	DPK-BA0001	O Ring	15	C-16	DSC-AA0018	Bolt	105	Q-31
CUL-KC0001	Shaft	25	H-8	DPK-BA0002	O Ring	15	C-15	DSC-AA0019	Bolt	21	F-38
DBR-AZ0001	Ball	37	M-34-2	DPK-BA0003	O Ring	107	Q-90	DSC-AA0019	Bolt	51	O5-37
DBR-AZ0001	Ball	37	M-36-3	DPK-BA0003	O Ring	21	F-18	DSC-AA0019	Bolt	55	O6-37
DBS-DA0043	Bushing	21	F-16-1	DPK-BA0003	O Ring	31	J-50	DSC-AA0019	Bolt	61	O7-48
DBS-DA0049	Bushing	105	Q-2	DPK-BA0003	O-Ring	101	O13-52	DSC-AA0019	Bolt	67	O8-43
DBS-DA0049	Bushing	105	Q-30	DPK-BA0004	O-Ring	99	O13-39	DSC-AA0019	Bolt	69	O8-43
DBS-DA0049	Bushing	27	I-4	DPK-BA0008	O-Ring	99	O13-38	DSC-AA0019	Bolt	73	O9-59
DBS-DA0049	Bushing	27	I-19	DPK-BB0002	O Ring	37	M-9	DSC-AA0019	Bolt	79	O10-74
DBS-DA0049	Bushing	31	J-55	DPK-BJ0008	O-Ring	39	M-42	DSC-AA0019	Bolt	87	O11-68
DBS-DA0050	Front Bush for Driving Needle Bar	21	F-41	DPK-CA0009	Plug	9	A-5	DSC-AA0019	Bolt	89	O11-68
DBS-DA0051	Rear Bush for Driving Needle Bar	21	F-42	DPK-CA0009	Plug	29	J-35	DSC-AC0002	Bolt	21	F-6
DBS-DA0052	Middle Bush for Crank Shaft Center	15	C-26	DPK-CA0009	Rubber Cap	99	O13-10	DSC-AC0002	Bolt	25	H-7
DBS-DA0053	Bush for Adjusting Differential Ratio Shaft	29	J-32	DPK-CA0010	Filter	23	G-30	DSC-AC0002	Bolt	29	J-12
DBS-DA0054	Front Bush for Knife Driving Shaft	33	K-27	DPK-CB0001	Plug	105	Q-56	DSC-AC0002	Bolt	33	K-4

Index

Parts No.	Name of Parts	Page	Ref.No.	Parts No.	Name of Parts	Page	Ref.No.	Parts No.	Name of Parts	Page	Ref.No.
DSC-AC0002	Bolt	51	O5-49	DSC-BF0047	Bolt(M4xL9)	31	J-69	DSC-BF0054	Screw	69	O8-47
DSC-AC0002	Bolt	55	O6-49	DSC-BF0047	Bolt(M4xL9)	31	J-71	DSC-BF0054	Screw	73	O9-52
DSC-AC0002	Bolt	61	O7-62	DSC-BF0048	Screw	25	H-18	DSC-BF0054	Screw	73	O9-55
DSC-AC0002	Bolt	67	O8-57	DSC-BF0048	Screw	27	I-29	DSC-BF0054	Screw	73	O9-63
DSC-AC0002	Bolt	69	O8-57	DSC-BF0049	Screw	23	G-23	DSC-BF0054	Screw	79	O10-67
DSC-AC0002	Bolt	73	O9-76	DSC-BF0049	Screw	27	I-25	DSC-BF0054	Screw	79	O10-70
DSC-AC0002	Bolt	81	O10-87	DSC-BF0049	Screw	37	M-1-7	DSC-BF0054	Screw	79	O10-78
DSC-AC0002	Bolt	87	O11-81	DSC-BF0049	Screw(M3.5xL7.5)	19	E-24	DSC-BF0054	Screw	83	O10-135
DSC-AC0002	Bolt	89	O11-81	DSC-BF0050	Screw	11	B-26	DSC-BF0054	Screw	87	O11-61
DSC-AC0002	Bolt	105	Q-12	DSC-BF0050	Screw	81	O10-112	DSC-BF0054	Screw	87	O11-64
DSC-AC0002	Bolt	105	Q-44	DSC-BF0050	Screw	87	O11-101	DSC-BF0054	Screw	87	O11-72
DSC-AC0002	Bolt (M6X12)	105	Q-53	DSC-BF0050	Screw	89	O11-101	DSC-BF0054	Screw	89	O11-61
DSC-AC0002	Bolt (M6X12)	107	Q-60	DSC-BF0050	Screw	93	O12-46	DSC-BF0054	Screw	89	O11-64
DSC-AC0002	Bolt (M6xL12)	23	G-7	DSC-BF0050	Screw	95	O12-46	DSC-BF0054	Screw	89	O11-72
DSC-AC0002	Bolt(M6xL12, P0.75)	29	J-38	DSC-BF0050	Screw(M4.5X6)	77	O10-16	DSC-BF0054	Screw	91	O11-117
DSC-AC0002	Bolt(M6xL12, P0.75)	31	J-42	DSC-BF0050	Screw(M4xL6)	29	J-25	DSC-BF0054	Screw	97	O12-62
DSC-AC0002	M6X12 BOLT	107	Q-69	DSC-BF0050	Screw/M4.5X6	93	O12-11	DSC-BF0054	Screw	101	O13-56
DSC-AC0002	Screw	27	I-15	DSC-BF0050	Screw/M4.5X6	95	O12-11	DSC-BF0054	Screw	107	Q-88
DSC-AC0002	Screw	27	I-17	DSC-BF0051	Screw	29	J-22	DSC-BF0054	Screw	111	R-20
DSC-AC0002	Screw	61	O7-63	DSC-BF0051	Screw (M4.5)	107	Q-95	DSC-BF0054	Screw (M4xL8)	59	O7-19
DSC-AC0003	Bolt (M6XP0.75L14)	107	Q-82	DSC-BF0052	Screw	35	L-19-2	DSC-BF0054	Screw(M4xL6)	17	D-4
DSC-AC0003	Bolt(M6XP0.75L14)	35	L-11	DSC-BF0052	Screw(M3.5xL8)	31	J-63	DSC-BF0054	Screw(M4xL6)	59	O7-15
DSC-AC0003	Screw (M6X14)	105	Q-15	DSC-BF0052	Screw(M3.5xL8)	31	J-66	DSC-BF0054	Screw(M4xL7.8)	19	E-4
DSC-AC0020	Bolt	99	O13-26	DSC-BF0052	Screw(M3.5xL8)	33	K-15	DSC-BF0054	Screw(M4xL7.8)	19	E-6
DSC-BA0001	Screw	113	S-7	DSC-BF0053	Joint Screw	37	M-11	DSC-BF0054	Screw(M4xL7.8)	19	E-18
DSC-BB0010	Screw	25	H-5	DSC-BF0053	Joint Screw	37	M-15	DSC-BF0054	Screw(M4xL8)	51	O5-10
DSC-BB0010	Screw (M3xL6)	23	G-5	DSC-BF0053	Joint Screw	37	M-19	DSC-BF0054	Screw(M4xL8)	55	O6-10
DSC-BB0010	Screw(M3X6)	73	O9-32	DSC-BF0053	Joint Screw	37	M-24	DSC-BF0054	Screw(M4xL8)	65	O8-14
DSC-BB0011	Screw	11	B-54	DSC-BF0053	Screw	83	O10-130	DSC-BF0054	Screw(M4Xl8)	71	O9-20
DSC-BB0011	Screw	21	F-29	DSC-BF0053	Screw	91	O11-112	DSC-BF0054	Screw(M4Xl8)	79	O10-31
DSC-BB0012	Screw	23	G-28	DSC-BF0053	Screw	97	O12-57	DSC-BF0054	Screw(M4Xl8)	85	O11-32
DSC-BB0041	Screw	11	B-8	DSC-BF0053	Screw	99	O13-31	DSC-BF0055	Screw	13	B-62
DSC-BB0041	Screw	99	O13-2	DSC-BF0054	Bolt	13	B-68	DSC-BF0056	Screw	11	B-52
DSC-BB0042	Screw	51	O5-25	DSC-BF0054	Screw	11	B-10	DSC-BF0057	Screw	23	G-33
DSC-BB0042	Screw	55	O6-25	DSC-BF0054	Screw	11	B-24	DSC-BF0057	Screw	27	I-46
DSC-BB0042	Screw	65	O8-29	DSC-BF0054	Screw	11	B-28	DSC-BF0057	Screw	27	I-48
DSC-BB0042	Screw	73	O9-47	DSC-BF0054	Screw	11	B-48	DSC-BF0057	Screw	35	L-19-4
DSC-BB0042	Screw	79	O10-59	DSC-BF0054	Screw	13	B-60	DSC-BF0057	Screw(M3xL3.5)	19	E-15
DSC-BF0007	Screw	11	B-35	DSC-BF0054	Screw	15	C-7	DSC-BF0057	Screw(M3xL3.5)	19	E-20
DSC-BF0036	Screw(11/64" n=40, L8)	43	O1-6	DSC-BF0054	Screw	21	F-31	DSC-BF0058	Screw	21	F-26
DSC-BF0036	Screw(11/64" n=40, L8)	45	O2-6	DSC-BF0054	Screw	21	F-34	DSC-BF0058	Screw	43	O1-14
DSC-BF0039	Screw	11	B-18	DSC-BF0054	Screw	21	F-36	DSC-BF0058	Screw	45	O2-13
DSC-BF0039	Screw	37	M-1-11	DSC-BF0054	Screw	27	I-33	DSC-BF0059	Screw	21	F-40
DSC-BF0039	Screw	101	O13-45	DSC-BF0054	Screw	27	I-53	DSC-BF0059	Screw	51	O5-39
DSC-BF0039	Screw	101	O13-60	DSC-BF0054	Screw	33	K-19	DSC-BF0059	Screw	55	O6-39
DSC-BF0039	Screw(M3x6)	19	E-11	DSC-BF0054	Screw	33	K-22	DSC-BF0059	Screw	61	O7-50
DSC-BF0039	Screw(M3X6)	73	O9-33	DSC-BF0054	Screw	35	L-27	DSC-BF0059	Screw	67	O8-45
DSC-BF0041	Screw	11	B-30	DSC-BF0054	Screw	37	M-8	DSC-BF0059	Screw	69	O8-45
DSC-BF0041	Screw	13	B-71	DSC-BF0054	Screw	51	O5-30	DSC-BF0059	Screw	73	O9-61
DSC-BF0041	Screw	15	C-18	DSC-BF0054	Screw	51	O5-33	DSC-BF0059	Screw	79	O10-76
DSC-BF0041	Screw(M4xL12)	11	B-13	DSC-BF0054	Screw	51	O5-41	DSC-BF0059	Screw	87	O11-70
DSC-BF0041	Screw(M4xL12)	11	B-29	DSC-BF0054	Screw	55	O6-30	DSC-BF0059	Screw	89	O11-70
DSC-BF0041	Screw(M4xL12)	29	J-19	DSC-BF0054	Screw	55	O6-33	DSC-BF0060	Screw	23	G-29
DSC-BF0041	Screw(M4XP0.7L10)	35	L-5	DSC-BF0054	Screw	55	O6-41	DSC-BF0066	Bolt(M4xL6)	31	J-47
DSC-BF0042	Screw	15	C-5	DSC-BF0054	Screw	61	O7-41	DSC-BF0067	Screw	35	L-19-6
DSC-BF0043	Screw	21	F-2	DSC-BF0054	Screw	61	O7-44	DSC-BF0068	Screw	35	L-19-14
DSC-BF0043	Screw	25	H-2	DSC-BF0054	Screw	61	O7-52	DSC-BF0069	Screw	35	L-19-10
DSC-BF0043	Screw	25	H-3	DSC-BF0054	Screw	67	O8-36	DSC-BF0084	Screw	41	N-4
DSC-BF0043	Screw	33	K-2	DSC-BF0054	Screw	67	O8-39	DSC-BF0151	Screw	51	O5-45
DSC-BF0043	Screw (M4xL16)	23	G-2	DSC-BF0054	Screw	67	O8-47	DSC-BF0151	Screw	55	O6-45
DSC-BF0043	Screw (M4xL16)	23	G-3	DSC-BF0054	Screw	69	O8-36	DSC-BF0151	Screw	61	O7-56
DSC-BF0044	Screw	21	F-21	DSC-BF0054	Screw	69	O8-39	DSC-BF0151	Screw	67	O8-51

Index

Parts No.	Name of Parts	Page	Ref.No.	Parts No.	Name of Parts	Page	Ref.No.	Parts No.	Name of Parts	Page	Ref.No.
DSC-BF0151	Screw	69	O8-51	DSC-CB0013	Screw	11	B-19	DSN-CD0003	Thread Tension Spring Cap Ass'Y	71	O9-16-1
DSC-BF0151	Screw	73	O9-67	DSC-CB0014	Screw	21	F-24	DSN-CD0003	Thread Tension Spring Cap Ass'Y	71	O9-17-1
DSC-BF0151	Screw	81	O10-82	DSC-CB0014	Screw	27	I-50	DSN-CD0003	Thread Tension Spring Cap Ass'Y	71	O9-18-1
DSC-BF0151	Screw	87	O11-76	DSC-CB0014	Screw	43	O1-12	DSN-CD0003	Thread Tension Spring Cap Ass'Y	77	O10-27-1
DSC-BF0151	Screw	89	O11-76	DSC-CB0014	Screw	45	O2-11	DSN-CD0003	Thread Tension Spring Cap Ass'Y	77	O10-28-1
DSC-BF0160	Bolt(M3X3.5)	77	O10-14	DSC-CB0014	Screw	51	O5-23	DSN-CD0003	Thread Tension Spring Cap Ass'Y	77	O10-29-1
DSC-BF0160	Bolt/M3X3.5	93	O12-9	DSC-CB0014	Screw	55	O6-23	DSN-CD0006	Nut(11/64" n=40)	59	O7-17
DSC-BF0160	Bolt/M3X3.5	95	O12-9	DSC-CB0014	Screw	61	O7-36	DSN-CY0001	Nut	41	N-24
DSC-BJ0016	Presser Foot Finger	35	L-19-12	DSC-CB0014	Screw	67	O8-31	DSN-CY0001	Nut	111	R-3
DSC-BJ0017	Screw	37	M-27	DSC-CB0014	Screw	69	O8-31	DSN-CY0009	Nut	15	C-9-3
DSC-BJ0018	Screw	13	B-82	DSC-CB0014	Screw	73	O9-45	DSN-CZ0003	Nut	29	J-21
DSC-BJ0018	Screw	13	B-86	DSC-CB0014	Screw	79	O10-46	DSN-CZ0003	Nut	107	Q-94
DSC-BJ0018	Screw	71	O9-8	DSC-CB0014	Screw	79	O10-61	DSP-AA0019	Spring	29	J-6
DSC-BJ0018	Screw	99	O13-15	DSC-CB0014	Screw	85	O11-27	DSP-AA0020	Spring	29	J-30
DSC-BJ0018	Screw(M4xL12)	13	B-92	DSC-CB0014	Screw	85	O11-45	DSP-AA0020	Spring	107	Q-106
DSC-BJ0018	Screw(M4xL10)	41	N-34	DSC-CB0014	Screw	93	O12-20	DSP-AA0021	Spring	33	K-20
DSC-BJ0019	Screw	11	B-22	DSC-CB0014	Screw	95	O12-20	DSP-AA0022	Spring	11	B-16
DSC-BJ0019	Screw	27	I-44	DSC-CB0015	Screw	21	F-17	DSP-AA0023	Spring	35	L-20
DSC-BJ0019	Screw	99	O13-16	DSC-CB0015	Set Screw	101	O13-51	DSP-AA0024	Thread Retainer Spring	19	E-9
DSC-BJ0019	Screw(M4xL5)	51	O5-14	DSC-CB0016	Screw	33	K-8	DSP-AC0011	Spring	29	J-1-12
DSC-BJ0019	Screw(M4xL5)	51	O5-18	DSC-CB0017	Screw	35	L-18	DSP-AC0012	Spring	29	J-17
DSC-BJ0019	Screw(M4xL5)	51	O5-20	DSC-CB0020	Screw	73	O9-42	DSP-AC0013	Spring	11	B-57
DSC-BJ0019	Screw(M4xL5)	55	O6-14	DSC-CB0020	Screw	79	O10-52	DSP-AC0014	Spring	35	L-25
DSC-BJ0019	Screw(M4xL5)	55	O6-18	DSC-CB0020	Screw	85	O11-51	DSP-AC0015	Spring	35	L-3
DSC-BJ0019	Screw(M4xL5)	55	O6-20	DSC-CB0020	Screw	93	O12-26	DSP-AC0016	Spring	35	L-12
DSC-BJ0019	Screw(M4xL5)	59	O7-23	DSC-CB0020	Screw	95	O12-26	DSP-AD0006	Flat Spring	29	J-1-7
DSC-BJ0019	Screw(M4xL5)	59	O7-27	DSC-FA0048	Screw	11	B-43	DSP-AD0007	Flat Spring	11	B-23
DSC-BJ0019	Screw(M4xL5)	59	O7-29	DSC-FA0048	Screw	13	B-65	DSP-AD0009	Spring	35	L-19-9
DSC-BJ0019	Screw(M4xL5)	65	O8-18	DSC-FA0048	Screw(M4)	77	O10-18	DSP-BA0005	Conical Spring	99	O13-18-3
DSC-BJ0019	Screw(M4xL5)	65	O8-22	DSC-FA0048	Screw/M4	85	O11-18	DSP-BA0005	Thread Tension Spring-Needle	17	D-1-3
DSC-BJ0019	Screw(M4xL5)	65	O8-24	DSC-FA0048	Screw/M4	93	O12-13	DSP-BA0005	Thread Tension Spring-Needle	59	O7-10-3
DSC-BJ0019	Screw(M4Xl5)	71	O9-24	DSC-FA0048	Screw/M4	95	O12-13	DSP-BA0005	Thread Tension Spring-Needle	71	O9-16-3
DSC-BJ0019	Screw(M4Xl5)	73	O9-28	DSC-FA0051	Screw(M2)	29	J-1-13	DSP-BA0005	Thread Tension Spring-Needle	77	O10-27-3
DSC-BJ0019	Screw(M4Xl5)	73	O9-30	DSC-FA0052	Screw	29	J-9	DSP-BA0006	Conical Spring	99	O13-17-3
DSC-BJ0019	Screw(M4Xl5)	79	O10-35	DSC-FA0053	Screw	29	J-14	DSP-BA0006	Thread Tension Spring-Looper	17	D-2-3
DSC-BJ0019	Screw(M4Xl5)	79	O10-39	DSC-FA0054	Screw	35	L-2	DSP-BA0027	Tension Spring	27	I-41
DSC-BJ0019	Screw(M4Xl5)	79	O10-41	DSC-FA0055	Screw(M2xP0.4xL3.2)	19	E-10	DWS-AA0032	Washer	111	R-21
DSC-BJ0019	Screw(M4Xl5)	85	O11-36	DSC-FA0182	Hinge Screw	101	O13-62	DWS-AA0032	Washer(4)	41	N-35
DSC-BJ0019	Screw(M4Xl5)	85	O11-40	DSC-FB0026	Bolt(M5xL13)	31	J-56	DWS-AA0043	Washer	21	F-10
DSC-BJ0019	Screw(M4Xl5)	85	O11-42	DSC-FB0026	Screw	27	I-5	DWS-AA0043	Washer	105	Q-16
DSC-BJ0021	Bolt(M4xL5)	31	J-74	DSC-FB0026	Screw	27	I-20	DWS-AA0043	Washer	105	Q-57
DSC-CA0013	Screw	37	M-1-4	DSC-FD0016	Screw	27	I-37	DWS-AA0044	Washer	25	H-12
DSC-CA0014	Screw	11	B-20	DSC-FG0003	Screw	33	K-10	DWS-AA0044	Washer	29	J-36
DSC-CB0001	Screw	35	L-14	DSC-GA0002	Screw	11	B-56	DWS-AA0045	Washer	27	I-6
DSC-CB0007	Main Feed Dog	61	O7-64	DSC-GA0003	Screw	35	L-24	DWS-AA0045	Washer	27	I-21
DSC-CB0007	Screw	15	C-9-4	DSC-GA0011	Hinge Screw	99	O13-40	DWS-AA0045	Washer	31	J-57
DSC-CB0007	Screw	37	M-33	DSC-HA0002	Screw	35	L-21	DWS-AA0045	Washer	105	Q-4
DSC-CB0007	Screw	51	O5-50	DSC-HC0002	Bed Pin	9	A-8	DWS-AA0045	Washer	105	Q-32
DSC-CB0007	Screw	55	O6-50	DSN-AA0003	Nut	113	S-5	DWS-AA0046	Washer	23	G-9
DSC-CB0007	Screw	67	O8-58	DSN-AA0014	Nut(M5)	31	J-44	DWS-AA0046	Washer	25	H-9
DSC-CB0007	Screw	69	O8-58	DSN-AA0014	Nut(M5XP0.8)	35	L-7	DWS-AA0047	Washer	37	M-30
DSC-CB0007	Screw	73	O9-77	DSN-AA0015	Nut	37	M-1-12	DWS-AA0047	Washer	29	J-5
DSC-CB0007	Screw	81	O10-88	DSN-AA0016	Nut	13	B-73	DWS-AA0048	Spring Washer	21	F-39
DSC-CB0007	Screw	87	O11-82	DSN-CC0002	Nut	35	L-22	DWS-AA0048	Washer	13	B-63
DSC-CB0007	Screw	89	O11-82	DSN-CD0003	Thread Tension Spring Cap Assy	59	O7-10-1	DWS-AA0048	Washer	101	O13-59
DSC-CB0007	Screw (M5X5)	105	Q-48	DSN-CD0003	Thread Tension Spring Cap Ass'Y	17	D-1-1	DWS-AA0048	Washer(0.4t)	19	E-16
DSC-CB0007	Screw (M5X5)	107	Q-71	DSN-CD0003	Thread Tension Spring Cap Ass'Y	17	D-2-1	DWS-AA0050	Washer	11	B-49
DSC-CB0007	Screw(M5xL5)	29	J-1-10	DSN-CD0003	Thread Tension Spring Cap Ass'Y	59	O7-11-1	DWS-AA0055	Washer	41	N-28
DSC-CB0007	Set Screw	99	O13-36	DSN-CD0003	Thread Tension Spring Cap Ass'Y	59	O7-12-1	DWS-AA0055	Washer	111	R-5
DSC-CB0012	Screw	21	F-4	DSN-CD0003	Thread Tension Spring Cap Ass'Y	65	O8-10-1	DWS-CA0001	Spring Washer	23	G-11
DSC-CB0012	Screw	33	K-6	DSN-CD0003	Thread Tension Spring Cap Ass'Y	65	O8-11-1	DWS-CA0001	Spring Washer	25	H-11
DSC-CB0012	Screw(M4xL6)	29	J-1-3	DSN-CD0003	Thread Tension Spring Cap Ass'Y	65	O8-12-1	DWS-CA0001	Spring Washer	27	I-10

Index

Parts No.	Name of Parts	Page	Ref.No.	Parts No.	Name of Parts	Page	Ref.No.	Parts No.	Name of Parts	Page	Ref.No.
DWS-CB0001	Spring	29	J-23	GP-023385	Earth Lable	9	A-9	GP-044969	Lever	107	Q-81
DWS-CB0003	Spring	77	O10-21	GP-034902	Oil Tube	83	O10-131	GP-044970	Latch	107	Q-85
DWS-CB0003	Spring	81	O10-113	GP-034902	Oil Tube	91	O11-113	GP-044971	Latch	107	Q-87
DWS-CB0003	Spring	87	O11-102	GP-034902	Oil Tube	97	O12-58	GP-044972	Lever	107	Q-91
DWS-CB0003	Spring	89	O11-102	GP-036612	Spanner (8mm)	41	N-8	GP-044973	Stopper	107	Q-100
DWS-CB0003	Spring	93	O12-16	GP-044393	Adjusting Bar	107	Q-104	GP-044974	Blade Guide	107	Q-97
DWS-CB0003	Spring	93	O12-47	GP-044402	Seal	29	J-28	GP-044975	Spacer	107	Q-99
DWS-CB0003	Spring	95	O12-16	GP-044402	Seal	107	Q-105	GP-045029	Block	107	Q-63
DWS-CB0003	Spring	95	O12-47	GP-044494	Cap	23	G-24	GP-045030	Link	107	Q-64
DWS-CC0001	Washer	11	B-41	GP-044671	Front Cover (Left)	51	O5-1	GP-045055	Crank	105	Q-52
DWS-CC0001	Washer	13	B-66	GP-044671	Front Cover (Left)	55	O6-1	GP-045056	Crank	107	Q-58
DWS-CC0001	Washer	27	I-38	GP-044671	Front Cover (Left)	59	O7-1	GP-045057	Crank	107	Q-68
DWS-CC0001	Wave Washer	101	O13-61	GP-044671	Front Cover (Left)	65	O8-1	GP-045180	Bracket	91	O11-111-1
DWS-CC0002	Washer	15	C-13	GP-044671	Front Cover (Left)	71	O9-3	GP-045180	Bracket	97	O12-56-1
EA-000101	SMPS(5V)	101	O13-63	GP-044671	Front Cover (Left)	77	O10-3	GP-045180	Bracket	83	O10-129-1
EA-000669	LED LAMP Box Ass'y	101	O13-53	GP-044671	Front Cover (Left)	85	O11-3	GP-045181	Joint	83	O10-129-2
G-NP-0003	Needle Plate	43	O1-15	GP-044747	Crank	69	O8-56	GP-045181	Joint	91	O11-111-2
G-NP-0004	Needle Plate	45	O2-15	GP-044795	Cover	85	O11-23	GP-045181	Joint	97	O12-56-2
G-NP-0005	Needle Plate	47	O3-2	GP-044834	Thread Tension Post	65	O8-11-7	GP-045182	Pipe	83	O10-129-3
G-NP-0006	Needle Plate	21	F-28	GP-044836	Thread Guide Bracket-Needle	85	O11-31	GP-045182	Pipe	91	O11-111-3
G-NP-0007	Needle Plate	49	O4-6	GP-044837	Thread Guide	85	O11-33-1	GP-045182	Pipe	97	O12-56-3
G-NP-0008	Needle Plate	51	O5-27	GP-044838	Thread Guide Holder	85	O11-35	GP-045184	Upper Looper Holder Base	61	O7-59-3
G-NP-0009	Needle Plate	55	O6-27	GP-044839	Thread Guide	85	O11-37-1	GP-045184	Upper Looper Holder Base	67	O8-54-3
G-NP-0010	Needle Plate	67	O8-33	GP-044841	Thread Guide	85	O11-41	GP-045184	Upper Looper Holder Base	69	O8-54-3
G-NP-0010	Needle Plate	69	O8-33	GP-044859	Looper Thread Take Up	61	O7-32	GP-045184	Upper Looper Holder Base	73	O9-72-3
G-NP-0010	Needle Plate	73	O9-49	GP-044859	Looper Thread Take Up	65	O8-27	GP-045184	Upper Looper Holder Base	81	O10-84-3
G-NP-0010	Needle Plate	79	O10-64	GP-044859	Looper Thread Take Up	73	O9-35	GP-045208	Model Mark	43	O1-2
G-NP-0010	Needle Plate	87	O11-58	GP-044859	Looper Thread Take Up	79	O10-44	GP-045209	Model Mark	45	O2-2
G-NP-0010	Needle Plate	89	O11-58	GP-044930	Silicone Oil Reservoir(Lower)	85	O11-9	GP-045209	Model Mark	45	O2-2
G-NP-0011	Needle Plate	61	O7-38	GP-044949	Felt	75	O9-98	GP-045210	Model Mark	47	O3-1
GP-000906	Stopper For Tension Spring	77	O10-29-2	GP-044949	Felt	83	O10-148	GP-045211	Model Mark	13	B-74
GP-001461	Thread Tension Spring Cap	17	D-1-1	GP-044949	Felt	91	O11-130	GP-045212	Model Mark	49	O4-2
GP-001461	Thread Tension Spring Cap	17	D-2-1	GP-044949	Felt	97	O12-75	GP-045213	Model Mark	51	O5-4
GP-001461	Thread Tension Spring Cap	59	O7-11-1-1	GP-044950	Cover	75	O9-99	GP-045214	Model Mark	55	O6-4
GP-001461	Thread Tension Spring Cap	59	O7-12-1-1	GP-044950	Felt Cover	83	O10-149	GP-045215	Model Mark	71	O9-6
GP-001461	Thread Tension Spring Cap	65	O8-10-1-1	GP-044950	Felt Cover	91	O11-131	GP-045216	Model Mark	59	O7-4
GP-001461	Thread Tension Spring CAP	65	O8-11-1-1	GP-044950	Felt Cover	97	O12-76	GP-045217	Model Mark	65	O8-4
GP-001461	Thread Tension Spring Cap	65	O8-12-1-1	GP-044951	Joint	83	O10-141-1	GP-045217	Model Mark	65	O8-4
GP-001461	Thread Tension Spring Cap	71	O9-16-1-1	GP-044951	Joint	91	O11-123-1	GP-045218	Model Mark	77	O10-6
GP-001461	Thread Tension Spring Cap	71	O9-17-1-1	GP-044951	Joint	97	O12-68-1	GP-045218	Model Mark	77	O10-6
GP-00146100	Thread Tension Spring Cap	71	O9-18-1-1	GP-044951	Joint	97	O12-68-1	GP-045219	Model Mark	85	O11-6
GP-001461	Thread Tension Spring Cap	77	O10-27-1-1	GP-044952	Bracket	83	O10-141-2	GP-045220	Model Mark	93	O12-3
GP-001461	Thread Tension Spring Cap	77	O10-28-1-1	GP-044952	Bracket	91	O11-123-2	GP-045220	Model Mark	95	O12-3
GP-001461	Thread Tension Spring Cap	77	O10-29-1-1	GP-044952	Bracket	97	O12-68-2	GP-045225	Thread Guide	59	O7-14
GP-001461	Thread Tension Spring Cap	77	O10-29-1-1	GP-044953	Pipe	83	O10-141-3	GP-045226	Thread Guide	59	O7-16
GP-001461	Thread Tension Spring Cap	59	O7-10-1-1	GP-044953	Pipe	91	O11-123-3	GP-045228	Thread Guide	59	O7-26
GP-001462	Bushing for Thread Tension Spring Cap	17	D-1-1	GP-044953	Pipe	97	O12-68-3	GP-045229	Thread Guide	73	O9-27
GP-001462	Bushing for Thread Tension Spring Cap	17	D-2-1	GP-044953	Pipe	97	O12-68-3	GP-045229	Thread Guide	79	O10-38
GP-001462	Bushing for Thread Tension Spring Cap	59	O7-11-1-2	GP-044954	Felt	75	O9-102	GP-045229	Thread Guide	79	O10-38
GP-001462	Bushing for Thread Tension Spring Cap	59	O7-12-1-2	GP-044954	Felt	83	O10-142	GP-045229	Thread Guide	85	O11-39
GP-001462	Bushing for Thread Tension Spring Cap	65	O8-11-1-2	GP-044954	Felt	91	O11-124	GP-045230	Thread Guide	73	O9-29
GP-001462	Bushing for Thread Tension Spring Cap	65	O8-12-1-2	GP-044954	Felt	97	O12-69	GP-045231	Needle Thread Take Up	73	O9-31
GP-001462	Bushing For Thread Tension Spring Cap	71	O9-16-1-2	GP-044955	Felt	83	O10-136	GP-045232	Thread Guide	93	O12-17
GP-001462	Bushing For Thread Tension Spring Cap	71	O9-17-1-2	GP-044955	Felt	91	O11-118	GP-045232	Thread Guide	95	O12-17
GP-001462	Bushing For Thread Tension Spring Cap	71	O9-18-1-2	GP-044955	Felt	97	O12-63	GP-045233	Thread Guide	61	O7-31
GP-001462	Bushing For Thread Tension Spring Cap	77	O10-27-1-2	GP-044956	Cover	83	O10-137	GP-045233	Thread Guide	65	O8-26
GP-001462	Bushing For Thread Tension Spring Cap	77	O10-28-1-2	GP-044956	Cover	91	O11-119	GP-045233	Thread Guide	73	O9-34
GP-001462	Bushing For Thread Tension Spring Cap	77	O10-29-1-2	GP-044956	Cover	97	O12-64	GP-045233	Thread Guide	79	O10-43
GP-001462	Bushing For Thread Tension Spring Cap	77	O10-29-1-2	GP-044957	Spacer	83	O10-138	GP-045234	Needle Thread Take Up	59	O7-30
GP-001462	Bushing for Thread Tension Spring Cap	59	O7-10-1-2	GP-044957	Spacer	91	O11-120	GP-045235	Lower Knife	61	O7-72
GP-001462	Bushing for Thread Tension Spring Cap	65	O8-10-1-2	GP-044957	Spacer	97	O12-65	GP-045235	Lower Knife (Thick)	67	O8-67
GP-001568	Guide for Pedal Chain	41	N-3	GP-044962	Joint	83	O10-132	GP-045235	Lower Knife (Thick)	69	O8-67
GP-001612	Machine Number Plate	13	B-76	GP-044962	Joint	91	O11-114	GP-045235	Lower Knife (Thick)	75	O9-86
GP-002421	Bottle of Oil	41	N-16	GP-044962	Joint	97	O12-59	GP-045235	Lower Knife (Thick)	81	O10-102
								GP-045236	Needle Thread Take Up	93	O12-18

Index

Parts No.	Name of Parts	Page	Ref.No.	Parts No.	Name of Parts	Page	Ref.No.	Parts No.	Name of Parts	Page	Ref.No.
GP-045236	Needle Thread Take Up	95	O12-18	GP-045529	Lever	87	O11-92	GP-045645	Face Cover	95	O12-2
GP-045237	Needle Thread Take Up	85	O11-43	GP-045529	Lever	89	O11-92	GP-045646	Oil Cover	77	O10-13
GP-045239	Connection Link	105	Q-1	GP-045529	Lever	93	O12-37	GP-045646	Oil Cover	85	O11-13
GP-045240	Guide	105	Q-23	GP-045529	Lever	95	O12-37	GP-045646	Oil Cover	93	O12-8
GP-045256	Connection	105	Q-50	GP-045531	Stopper	81	O10-111	GP-045646	Oil Cover	95	O12-8
GP-045283	Frame	71	O9-1	GP-045531	Stopper	87	O11-100	GP-045647	Cover	77	O10-17
GP-045283	Frame	77	O10-1	GP-045531	Stopper	89	O11-100	GP-045647	Cover	85	O11-17
GP-045283	Frame	85	O11-1	GP-045531	Stopper	93	O12-45	GP-045647	Cover	93	O12-12
GP-045283	Frame	93	O12-1	GP-045531	Stopper	95	O12-45	GP-045647	Cover	95	O12-12
GP-045283	Frame	95	O12-1	GP-045533	Pipe	83	O10-141-4	GP-045824	Threading Diagram 1	49	O4-1
GP-045358	Block	107	Q-59	GP-045533	Pipe	91	O11-123-4	GP-045825	Threading Diagram 1	85	O11-4
GP-045455	Felt	107	Q-74	GP-045533	Pipe	97	O12-68-4	GP-045826	Threading Diagram 1	65	O8-2
GP-045456	Felt	107	Q-75	GP-045536	Lever	81	O10-114	GP-045826	Threading Diagram 1	77	O10-4
GP-045456	Felt "B" Of Clank Shaft	105	Q-20	GP-045536	Lever	87	O11-103	GP-045827	Threading Diagram 1	59	O7-2
GP-045457	Felt	107	Q-73	GP-045536	Lever	89	O11-103	GP-045827	Threading Diagram 1	71	O9-4
GP-045457	Felt "C" of crank shaft for upper feed	105	Q-22	GP-045536	Lever	93	O12-48	GP-045827	Threading Diagram 1	71	O9-4
GP-045458	Ball	107	Q-76	GP-045536	Lever	95	O12-48	GP-045828	Threading Diagram 2	85	O11-5
GP-045458	Ball of crank shaft for upper feed	105	Q-21	GP-045540	Exhaust Oil Distributor	83	O10-146	GP-045830	Upper Looper	61	O7-60
GP-045484	Lever	73	O9-36	GP-045540	Exhaust Oil Distributor	91	O11-128	GP-045830	Upper Looper	81	O10-85
GP-045484	Lever	79	O10-49	GP-045540	Exhaust Oil Distributor	97	O12-73	GP-045830	Upper Looper	67	O8-55
GP-045484	Lever	85	O11-48	GP-045550	Collar	81	O10-105	GP-045830	Upper Looper	69	O8-55
GP-045484	Lever	93	O12-23	GP-045550	Collar	87	O11-94	GP-045833	Upper Looper	73	O9-73
GP-045484	Lever	95	O12-23	GP-045550	Collar	89	O11-94	GP-045835	Lower Looper A	73	O9-74
GP-045488	Connection	73	O9-68	GP-045550	Collar	93	O12-39	GP-045847	Fabric Guide	77	O10-15
GP-045515	Stopper	75	O9-89	GP-045550	Collar	95	O12-39	GP-045847	Fabric Guide	85	O11-15
GP-045515	Stopper	81	O10-104	GP-045551	Cover	71	O9-7	GP-045847	Fabric Guide	93	O12-10
GP-045515	Stopper	87	O11-93	GP-045552	Crank	79	O10-53	GP-045847	Fabric Guide	95	O12-10
GP-045515	Stopper	89	O11-93	GP-045552	Crank	87	O11-52	GP-045849	Crank	73	O9-69
GP-045515	Stopper	93	O12-38	GP-045552	Crank	89	O11-52	GP-045853	Cover	77	O10-19
GP-045515	Stopper	95	O12-38	GP-045552	Crank	89	O11-52	GP-045853	Cover	85	O11-19
GP-045516	Upper Looper Holder A	73	O9-72-1	GP-045552	Crank	93	O12-27	GP-045853	Cover	93	O12-14
GP-045520	Collar	61	O7-75	GP-045552	Crank	95	O12-27	GP-045853	Cover	95	O12-14
GP-045520	Collar	67	O8-70	GP-045552	Link	73	O9-37	GP-045854	Felt	85	O11-7
GP-045520	Collar	69	O8-70	GP-045582	Cloth Guide Bracket	113	S-1-1	GP-045855	Thread Guide	85	O11-8
GP-045520	Collar	75	O9-91	GP-045583	Hinge/Edge Guide Bracket	113	S-2	GP-046036	Needle Holder Assy.	85	O11-26
GP-045520	Collar	81	O10-121	GP-045584	Stopper	113	S-6	GP-046037	Needle Holder Assy.	73	O9-44
GP-045521	Shaft	61	O7-79	GP-045585	Edge Guide Bracket	113	S-13	GP-046038	Needle Holder Assy.	65	O8-30
GP-045521	Shaft	67	O8-74	GP-045586	Edge Guide	113	S-18	GP-046038	Needle Holder Assy.	79	O10-60
GP-045521	Shaft	69	O8-74	GP-045587	Edge Guide	113	S-19	GP-046039	Needle Holder Assy.	61	O7-35
GP-045521	Shaft	75	O9-95	GP-045588	Angled Upper Knife Clamp	81	O10-94	GP-046146	Top Feed Dog	83	O10-152
GP-045521	Shaft	81	O10-125	GP-045589	Angled Knife	81	O10-95	GP-046146	Top Feed Dog	105	Q-37
GP-045524	Bracket	81	O10-109-1	GP-045590	Angled Upper Knife Gib	81	O10-97	GP-046147	Top Feed Dog	97	O12-79
GP-045524	Bracket	87	O11-98-1	GP-045591	Waste Guard	81	O10-98	GP-046165	Thread Guide	85	O11-28
GP-045524	Bracket	89	O11-98-1	GP-045633	Crank	105	Q-8	GP-046166	Thread Guide	61	O7-33
GP-045524	Bracket	93	O12-43-1	GP-045634	OIL SEAL	105	Q-24	GP-046166	Thread Guide	65	O8-28
GP-045524	Bracket	95	O12-43-1	GP-045635	Top Feed Dog Support	105	Q-26	GP-046166	Thread Guide	73	O9-46
GP-045525	Link	81	O10-117	GP-045636	Top Feed Guide "A"	105	Q-27	GP-046166	Thread Guide	79	O10-58
GP-045525	Link	91	O11-106	GP-045637	Guide "B"	105	Q-33	GP-046179	Flat Knife	61	O7-69
GP-045525	Link	93	O12-51	GP-045638	Guide "C"	105	Q-35	GP-046179	Flat knife	67	O8-64
GP-045525	Link	95	O12-51	GP-045639	Top Feed Dog	91	O11-134	GP-046179	Flat knife	69	O8-64
GP-045526	Link	81	O10-116-1	GP-045640	Presser Bar	105	Q-39	GP-046179	Plate Knife	75	O9-84
GP-045526	Link	87	O11-105-1	GP-045641	Crank	83	O10-153	GP-046198	Oil Felt	63	O7-85
GP-045526	Link	89	O11-105-1	GP-045641	Crank	91	O11-135	GP-046199	Crank	49	O4-4
GP-045526	Link	93	O12-50-1	GP-045641	Crank	105	Q-43	GP-046200	Needle	85	O11-30
GP-045526	Link	95	O12-50-1	GP-045642	Crank	97	O12-80	GP-046201	Needle	73	O9-48
GP-045527	Lever	61	O7-80	GP-045643	Bracket	85	O11-11	GP-046202	Needle	61	O7-37
GP-045527	Lever	67	O8-75	GP-045643	Bracket	93	O12-6	GP-046202	Needle	67	O8-32
GP-045527	Lever	69	O8-75	GP-045643	Bracket	95	O12-6	GP-046202	Needle	69	O8-32
GP-045527	Lever	75	O9-96	GP-045644	Bracket	77	O10-11	GP-046202	Needle	79	O10-62
GP-045527	Lever	81	O10-126	GP-045645	Face Cover	71	O9-2	GP-046412	Oil Wick	21	F-15
GP-045529	Lever	75	O9-88	GP-045645	Face Cover	77	O10-2	GP-046413	Oil Wick	23	G-19
GP-045529	Lever	81	O10-103	GP-045645	Face Cover	85	O11-2	GP-046413	Oil Wick	73	O9-41
GP-045529	Lever	81	O10-103	GP-045645	Face Cover	93	O12-2	GP-046413	Oil Wick	79	O10-57

Index

Parts No.	Name of Parts	Page	Ref.No.	Parts No.	Name of Parts	Page	Ref.No.	Parts No.	Name of Parts	Page	Ref.No.
GP-046413	Oil Wick	83	O10-147	PPK-BA0014	O Ring	97	O12-61	PSC-CB0002	Screw	39	M-40
GP-046413	Oil Wick	87	O11-56	PPK-BB0003	O-Ring	27	I-12	PSC-CB0002	Screw	75	O9-104
GP-046413	Oil Wick	89	O11-56	PPN-AF0005	Spring Pin	9	A-1	PSC-CB0002	Screw	105	Q-34
GP-046413	Oil Wick	91	O11-129	PPN-AF0005	Spring Pin	9	A-6-3	PSC-CB0002	Screw	105	Q-36
GP-046413	Oil Wick	93	O12-31	PPN-AF0006	Spring Pin	9	A-2	PSC-CB0002	Screw(M4xL4)	31	J-53
GP-046413	Oil Wick	95	O12-31	PSC-AC0012	Bolt	99	O13-24	PSC-CB0002	Screw(M4xL4)	83	O10-151
GP-0464130	Oil Wick	97	O12-74	PSC-AC0030	Screw(M5XP0.8L24)	35	L-6	PSC-CB0002	Screw(M4xL4)	91	O11-133
GP-046413	Oil Wick	105	Q-18	PSC-AC0049	Screw	41	N-1-3	PSC-CB0002	Screw(M4xL4)	97	O12-78
GP-046425	Tube	83	O10-140	PSC-AC0049	Screw	41	N-1-7	PSC-CB0002	Screw(M4xL4)	19	E-2
GP-046425	Tube	83	O10-144	PSC-AC0050	Screw	61	O7-70	PSC-CB0002	Screw(M4xL4)	51	O5-12
GP-046425	Tube	91	O11-122	PSC-AC0050	Screw	67	O8-65	PSC-CB0002	Screw(M4xL4)	51	O5-16
GP-046425	Tube	91	O11-126	PSC-AC0050	Screw	69	O8-65	PSC-CB0002	Screw(M4xL4)	55	O6-12
GP-046425	Tube	97	O12-67	PSC-AC0050	Screw	81	O10-99	PSC-CB0002	Screw(M4xL4)	55	O6-16
GP-046425	Tube	97	O12-71	PSC-AC0057	Bolt	9	A-7	PSC-CB0002	Screw(M4xL4)	59	O7-21
GP-046552	Needle Thread Take Up	65	O8-25	PSC-AC0057	Bolt(M6X25)	77	O10-12	PSC-CB0002	Screw(M4xL4)	59	O7-25
GP-046553	Needle Thread Take Up	49	O4-3	PSC-AC0057	Bolt/M6X25	85	O11-12	PSC-CB0002	Screw(M4xL4)	65	O8-16
GP-046757	Head Cover	41	N-18	PSC-AC0057	Bolt/M6X25	93	O12-7	PSC-CB0002	Screw(M4xL4)	65	O8-20
GP-047496	Auxiliary Plate	111	R-10	PSC-AC0057	Bolt/M6X25	95	O12-7	PSC-CB0002	Screw(M4Xl4)	71	O9-22
GP-047497	Motor Plate	111	R-13	PSC-AC0059	Screw	15	C-3	PSC-CB0002	Screw(M4Xl4)	71	O9-26
GP-047499	Bracket	111	R-19	PSC-AC0060	Bolt	15	C-22	PSC-CB0002	Screw(M4Xl4)	79	O10-33
GP-047827	Connection Bar	111	R-4	PSC-AC0061	Bolt	99	O13-12	PSC-CB0002	Screw(M4Xl4)	79	O10-37
GP-048239	SC Series Sticker	9	A-11	PSC-AC0061	Screw	37	M-29	PSC-CB0002	Screw(M4Xl4)	85	O11-34
MT-000646	Servo Motor(300W)	99	O13-25	PSC-AC0062	Bolt	99	O13-6	PSC-CB0002	Screw(M4Xl4)	85	O11-38
NB-000002	Needle Bar	79	O10-48-2	PSC-AC0062	Bolt	99	O13-34	PSC-CB0007	Screw	15	C-21
NB-000002	Needle Bar	85	O11-47-2	PSC-AC0062	Screw	11	B-2	PSC-CB0007	Set Screw	99	O13-23
NB-000002	Needle Bar	93	O12-22-2	PSC-AC0062	Screw	13	B-72	PSC-CB0007	Set Screw	99	O13-28
NB-000002	Needle Bar	95	O12-22-2	PSC-AC0062	Screw	37	M-2	PSC-CB0008	Screw(M3xL4)	29	J-1-8
NB-000003	Needle Bar	73	O9-43-2	PSC-AC0062	Screw	37	M-5	PSC-CB0009	Screw	23	G-20
PBR-AA0026	Ball Bearing	15	C-11	PSC-AC0062	Screw	37	M-23	PSC-DA0003	Tapping Screw	101	O13-54-3
PBR-AA0027	Ball Bearing	15	C-9-1	PSC-AC0063	Screw	51	O5-35	PSN-AA0015	Nut	41	N-1-4
PBR-AA0028	Ball Bearing	15	C-12	PSC-AC0063	Screw	51	O5-43	PSN-AA0015	Nut	41	N-1-8
PBR-AD0007	Plug	13	B-91	PSC-AC0063	Screw	55	O6-35	PSN-AA0015	Nut	111	R-25
PBR-AD0007	Plug	37	M-22-2	PSC-AC0063	Screw	55	O6-43	PSN-AA0030	Nut	111	R-6
PBR-BA0011	Needle Bearing	29	J-1-4	PSC-AC0063	Screw	61	O7-46	PSN-AA0030	Nut	111	R-12
PBR-BF0005	Needle Bearing	27	I-2	PSC-AC0063	Screw	61	O7-54	PSN-AA0030	Nut	111	R-16
PN-000703	Pin	107	Q-107	PSC-AC0063	Screw	67	O8-41	PSR-AB0005	Ring	15	C-10
PN-000727	Pin	85	O11-22	PSC-AC0063	Screw	67	O8-49	PSR-AC0003	Retaining Ring	107	Q-62
PN-000732	Pin	13	B-94	PSC-AC0063	Screw	69	O8-41	PSR-AC0004	Retaining Ring	107	Q-108
PN-000734	Pin	107	Q-61	PSC-AC0063	Screw	69	O8-49	PSR-AC0004	Ring(Ø3)	29	J-7
PN-000735	Pin	107	Q-66	PSC-AC0063	Screw	73	O9-57	PSR-AC0004	Ring(Ø3)	29	J-29
PN-000754	Pin For Cloth Guide Bracket	113	S-1-2	PSC-AC0063	Screw	73	O9-65	PSR-AC0005	Ring	29	J-10
PN-000755	Pin	113	S-8	PSC-AC0063	Screw	79	O10-72	PSR-AC0006	Retaining Ring	105	Q-55
PN-000756	Pin	73	O9-40	PSC-AC0063	Screw	79	O10-80	PSR-AC0006	Ring	21	F-11
PN-000756	Pin	79	O10-56	PSC-AC0063	Screw	87	O11-66	PSR-AC0009	Retaining Ring	61	O7-78
PN-000756	Pin	87	O11-55	PSC-AC0063	Screw	87	O11-74	PSR-AC0009	Retaining Ring	67	O8-73
PN-000756	Pin	89	O11-55	PSC-AC0063	Screw	89	O11-66	PSR-AC0009	Retaining Ring	69	O8-73
PN-000756	Pin	93	O12-30	PSC-AC0063	Screw	89	O11-74	PSR-AC0009	Retaining Ring	75	O9-94
PN-000756	Pin	95	O12-30	PSC-AC0063	Screw(M3xL6)	29	J-39	PSR-AC0009	Retaining Ring	81	O10-124
PN-000759	Pin	105	Q-19	PSC-AC0063	Screw(M3xL6)	31	J-62	PSR-AC0009	Ring(Ø7)	29	J-34
PN-000790	Lever Pin C	21	F-43	PSC-AC0065	Bolt(M8XL40)	111	R-11	PTC-AH0008	Cable Holder	101	O13-64
PN-000791	Pin C	21	F-44	PSC-AC0065	Bolt(M8xL45)	41	N-26	PTC-CA0001	Needle	49	O4-5
PPK-BA0004	O Ring	29	J-4	PSC-AC0065	Bolt(M8XL45)	111	R-14	PTC-CA0001	Needle	51	O5-26
PPK-BA0005	O Ring	29	J-16	PSC-AC0123	Screw	41	N-1-2	PTC-CA0004	Needle	21	F-27
PPK-BA0005	O Ring	39	M-39	PSC-BA0013	Screw	11	B-46	PTC-CA0004	Needle	45	O2-14
PPK-BA0005	O Ring	75	O9-103	PSC-CA0001	Needle	55	O6-26	PTL-AB0001	L-Type Hexagonal Wrench(2mm)	41	N-11
PPK-BA0005	O Ring	81	O10-128	PSC-CB0002	M4X4 SCREW	107	Q-65	PTL-AB0003	L-Type Hexagonal Wrench(2.5mm)	41	N-12
PPK-BA0005	O Ring	83	O10-143	PSC-CB0002	M4X4 SCREW	107	Q-67	PTL-AB0004	L-Type Hexagonal Wrench(4mm)	41	N-14
PPK-BA0005	O Ring	91	O11-110	PSC-CB0002	Screw	11	B-15	PTL-AB0005	L-Type Hexagonal Wrench(3mm)	41	N-13
PPK-BA0005	O Ring	91	O11-125	PSC-CB0002	Screw	11	B-40	PTL-AB0006	L-Type Hexagonal Wrench(1.5mm)	41	N-10
PPK-BA0005	O Ring	97	O12-55	PSC-CB0002	Screw	21	F-9	PTL-BA0001	Screw Driver(L)	41	N-9
PPK-BA0005	O Ring	97	O12-70	PSC-CB0002	Screw	37	M-35	PWS-AA0009	Washer	27	I-9
PPK-BA0014	O Ring	91	O11-116	PSC-CB0002	Screw	37	M-37	PWS-AA0009	Washer	31	J-45

Index

Parts No.	Name of Parts	Page	Ref.No.	Parts No.	Name of Parts	Page	Ref.No.	Parts No.	Name of Parts	Page	Ref.No.
PWS-AA0013	Washer	113	S-15	SN-000279	Nut	107	Q-102	ST-000122	Crank Shaft	65	O8-5
PWS-AA0013	Washer	113	S-17	SN-000283	Nut	105	Q-7	ST-000122	Crankshaft	77	O10-22
PWS-AA0018	Washer	29	J-26	SN-000289	Nut	79	O10-54	ST-000123	Crankshaft	71	O9-11
PWS-BC0001	Washer	41	N-29	SN-000289	Nut	87	O11-53	WS-000043	Spring	107	Q-96
PWS-CA0007	Spring Washer	113	S-12	SN-000289	Nut	89	O11-53	WS-000178	Spring	85	O11-21
PWS-CA0013	Spring Washer	15	C-23	SN-000289	Nut	93	O12-28	WS-000538	Spring Washer	51	O5-38
PWS-CA0014	Spring Washer	11	B-47	SN-000289	Nut	95	O12-28	WS-000538	Spring Washer	55	O6-38
PWS-CA0015	Spring Washer	41	N-27	SN-000289	Pin	73	O9-38	WS-000538	Spring Washer	61	O7-49
RI-000009	O Ring	83	O10-134	SN-000292	Nut for Pressure Regulating Screw	105	Q-42	WS-000538	Spring Washer	67	O8-44
SC-000236	Screw	113	S-11	SN-000306	Nut	111	R-9	WS-000538	Spring Washer	69	O8-44
SC-000283	Screw(M4X5.4)	77	O10-20	SP-000019	Thread Tension Spring-Needle	65	O8-10-3	WS-000538	Spring Washer	73	O9-60
SC-000283	Screw/M4X5.4	85	O11-20	SP-000028	Spring	107	Q-86	WS-000538	Spring Washer	79	O10-75
SC-000283	Screw/M4X5.4	93	O12-15	SP-000038	Thread Tension Spring-Needle	59	O7-11-3	WS-000538	Spring Washer	87	O11-69
SC-000283	Screw/M4X5.4	95	O12-15	SP-000038	Thread Tension Spring-Needle	71	O9-17-3	WS-000538	Spring Washer	89	O11-69
SC-000367	Screw (M6X10)	107	Q-84	SP-000038	Thread Tension Spring-Needle	77	O10-28-3	WS-000550	Washer	73	O9-71
SC-000396	Screw	81	O10-96	SP-000039	Thread Tension Spring-Looper	59	O7-12-3	WS-000557	Washer	105	Q-49
SC-000397	Screw/M4.5X6	85	O11-16	SP-000039	Thread Tension Spring-Looper	65	O8-12-3	WS-000563	Washer	61	O7-77
SC-000446	Bolt/M3X3.5	85	O11-14	SP-000039	Thread Tension Spring-Looper	71	O9-18-3	WS-000563	Washer	67	O8-72
SC-000715	Screw	81	O10-127-2	SP-000039	Thread Tension Spring-Looper	77	O10-29-3	WS-000563	Washer	69	O8-72
SC-000715	Screw	91	O11-109-2	SP-000040	Flat Spring	105	Q-13	WS-000563	Washer	75	O9-93
SC-000715	Screw	97	O12-54-2	SP-000055	Spring	81	O10-110	WS-000563	Washer	81	O10-123
SC-000850	Screw	51	O5-8	SP-000055	Spring	87	O11-99	WS-000571	Washer	61	O7-58
SC-000850	Screw	55	O6-8	SP-000055	Spring	89	O11-99	WS-000571	Washer	67	O8-53
SC-000850	Screw	59	O7-9	SP-000055	Spring	93	O12-44	WS-000571	Washer	69	O8-53
SC-000850	Screw	65	O8-9	SP-000055	Spring	95	O12-44	WS-000572	Washer	105	Q-29
SC-000850	Screw	71	O9-15	SP-000056	Spring	81	O10-107	WS-000574	Spring Washer	113	S-4
SC-000850	Screw	77	O10-26	SP-000056	Spring	87	O11-96	WS-000580	Washer	81	O10-100
SC-000850	Screw	85	O11-25	SP-000056	Spring	89	O11-96	WS-000597	Washer	111	R-15
SC-001234	Screw	11	B-36	SP-000056	Spring	93	O12-41	WS-000597	Washer	111	R-18
SC-001646	Screw	105	Q-6	SP-000056	Spring	95	O12-41	WS-000598	Washer	111	R-8
SC-001647	Screw	75	O9-100	SP-000058	Flat Spring	113	S-9	-	CD Manual	41	N-37
SC-001647	Screw	83	O10-150	SP-000061	Spring	105	Q-40	-	Inner Box	41	N-36
SC-001647	Screw	91	O11-132	SR-000005	Ring	31	J-49	-	Needle (DBx1 5Nm 90/14)	41	N-19
SC-001647	Screw	97	O12-77	ST-000040	Shaft	107	Q-89	-	Needle (DBx27 10Nm 130/21)	41	N-19
SC-001655	Screw (M4X18)	105	Q-51	ST-000044	Shaft	105	Q-54	-	Needle (DBx27 10Nm 70/10)	41	N-19
SC-001679	M4X6 Screw	91	O11-121	ST-000051	Crank Shaft	107	Q-72				
SC-001679	M4X6 Screw	97	O12-66	ST-000062	Upper Knife Lever	75	O9-82				
SC-001679	Screw(M4X6)	83	O10-139	ST-000062	Upper Knife Lever	81	O10-93				
SC-001680	Screw	81	O10-118	ST-000062	Upper Knife Lever	87	O11-87				
SC-001680	Screw	91	O11-107	ST-000062	Upper Knife Lever	89	O11-87				
SC-001680	Screw	97	O12-52	ST-000062	Upper Knife Lever	93	O12-36				
SC-001687	Screw	113	S-3	ST-000062	Upper Knife Lever	95	O12-36				
SC-001688	Screw	73	O9-39	ST-000085	Shaft	61	O7-74				
SC-001688	Screw	79	O10-51	ST-000085	Shaft	67	O8-69				
SC-001688	Screw	85	O11-50	ST-000085	Shaft	69	O8-69				
SC-001688	Screw	93	O12-25	ST-000085	Shaft	75	O9-90				
SC-001688	Screw	95	O12-25	ST-000085	Shaft	81	O10-120				
SC-001694	Screw (M6X23)	105	Q-9	ST-000086	Shaft	81	O10-116-2				
SC-001695	Pressure Regulating Screw	105	Q-41	ST-000086	Shaft	91	O11-105-2				
SC-001703	Screw	79	O10-55	ST-000086	Shaft	93	O12-50-2				
SC-001703	Screw	87	O11-54	ST-000086	Shaft	95	O12-50-2				
SC-001703	Screw	89	O11-54	ST-000087	Shaft	81	O10-109-2				
SC-001703	Screw	93	O12-29	ST-000087	Shaft	87	O11-98-2				
SC-001703	Screw	95	O12-29	ST-000087	Shaft	89	O11-98-2				
SC-001721	Screw	61	O7-34	ST-000087	Shaft	93	O12-43-2				
SC-001721	Screw	85	O11-29	ST-000087	Shaft	95	O12-43-2				
SC-001723	Screw(ST3.5)	41	N-32	ST-000094	Top Feed Rocker Shaft	105	Q-17				
SC-001724	Screw	113	S-10	ST-000095	Shaft	79	O10-47				
SC-001750	Screw	111	R-24	ST-000095	Shaft	85	O11-46				
SC-001769	Bolt	111	R-7	ST-000095	Shaft	93	O12-21				
SC-001770	Bolt(M8XL60)	111	R-17	ST-000095	Shaft	95	O12-21				
SC-0109-2350	Bolt	23	G-26	ST-000122	Crank Shaft	59	O7-5				

