



---

# PARTS BOOK

---

## SPS/D-BH6000

모터직결형 전자 제어식 아일렛  
단추구멍재봉기

Direct Drive, Electronically  
Controlled Eyelet Button Holing  
M/C

PME-131125

# Information

## A. Parts Book 구성

### Structure of Part Book

① **A** Arm, Bed & Machine Body Mechanism  
팔, 침대 및 의장품 관계

②

③

Ref. No.	Parts No.	Note	Name of Parts	중 명	Q'ty	Assembly No.
A-1	01-1284(-03)		Arm	팔	1	
A-2	01-1007(-06)		Bed	침대	1	
A-4	01-0210(-00)		Face Plate	면판	1	
A-5	01-0204(-12H)		Face Plate Gasket	면판 가스켓	1	
A-6	01-1174(-4122)		Screw(L)104*mm(2)	볼트	10	
A-7	01-1101(-123D)		Rubber Cap For Face Plate	면판 고무캡	2	
A-9	01-0018(-123D)		Caution S/Screw	경고 스크류	1	
A-8	01-01197(-00)		Turn-up Lever Cover	날리기 PWA	1	
A-10	01-0203(-04*mm(2))		Screw(S)104*mm(2)	볼트(S)104*mm(2)	1	
A-11	01-0174(-00)		Bed Cover(L)	침대 커버(좌)	1	
A-12	01-0148(-123H)		Bed Cover(Gasket,L)	침대 커버 가스켓(좌)	1	
A-13	01-0243(-123D)		Screw(L)104*mm(2)	볼트(L)104*mm(2)	14	
A-13-1	45-0244(-100)		Washer	와셔	2	
A-14	01-0175(-123D)		Bed Cover(R)	침대 커버(우)	1	
A-15	01-0176(-123H)		Bed Cover(Gasket,R)	침대 커버 가스켓(우)	1	
A-16	440211(-100H)		Tank Rubber Cap	고압 탱크 고무캡	1	
A-17	01-0274(-123D)		Thread Guide with Three Poles	세극을 안내하는 가이드	15Set	
A-19	01-0201(-123D)		Thread Guide(L)	가이드 실리(좌)	1	
A-20	01-0202(-123D)		Thread Guide(R)	가이드 실리(우)	3	
A-21	01-0100(-123D)		Thread Guide(S)	가이드 실리	1	
A-22	01-0163(-00)		Arm Thread Guide Assy	팔용 실리(L) 실리(우)	1	
A-23	11-0175(-752D)		Nut	너트	1	
A-24	01-0203(-123H)		Thread Guide(S)	실리(우)	1	
A-25	010275(-100H)		Siscon Tank Assy	실리콘 탱크 용접부	15Set	
A-26	010206(-100H)		Siscon Tank	실리콘 탱크	1	
A-27	010206(-100H)		Siscon Oil Window	실리콘 유량 창	1	
A-28	010240(-100H)		Siscon Part	실리콘 부품 용접 부	1	
A-29	01-1305(-00)		Part for Siscon Oil Supply	실리콘 기름 공급 부품	1	
A-30	01-0164(-123D)		Screw(L)104*mm(2)	볼트(L)	1	
A-31	04-0241(-123D)		Arm Upper Part Rubber Cap	팔용 상부 고무 캡	2	
A-33	04-0201(-100H)		Needle Bar Rubber Cap	바늘봉 고무 캡	1	
A-34	01-0431(-442L)		Rubber Cap(L)	고무캡(좌)	4	
A-35	44-0211(-742D)		Rubber Cap(R)	고무캡(우)	7	
A-36	01-0176(-123H)		Bed Rubber	침대 고무	1	
A-37	01-0191(-00)		Welder (Sticker,H)	고열 스티커-수용용	1	
A-38	01-0191(-00)		M Welder (Sticker,M)	고열 스티커-일반용	1	
A-39	01-0192(-00)		L Welder (Sticker,L)	고열 스티커-대용량	1	
A-40	01-0192(-00)		K Welder (Sticker,K)	고열 스티커-대용량	1	
A-41	01-0211(-123D)		Tap Cover	타프 커버	2	
A-42	01-0214(-123H)		Tap Cover	타프 커버	1	
A-43	41-0114(-100H)		Siscon Winder Assy	실리콘(좌)	15Set	
A-44	41-0201(-100H)		Siscon Winder (Base Assy)	실리콘 베이스(좌)	1	
A-45	41-0204(-123H)		Siscon Winder (Shaft)	실리콘 구동축	1	
A-46	01-0205(-00)	S. Option	Sticker(S)	태그 스티커	1	
A-47	01-0101(-752D)		Screw(S)	볼트(S)	1	
A-48	41-0205(-100H)		Siscon Winder	실리콘(우)	1	
A-49	01-0104(-552T)		Screw(L)104*mm(2)	볼트(L)	2	
A-50	41-0203(-100H)		Siscon Winder Action Ring	실리콘 작동링	1	
A-51	41-0204(-100H)		Siscon Winder Shaft Rubber Ring	실리콘 구동축 고무링	1	
A-52	41-0210(-100H)		Siscon Winder Lever	실리콘 레버	1	
A-53	41-0211(-100H)		Siscon Winder Adjusting Plate	실리콘 조정판	1	
A-54	01-0130(-123D)		Screw(L)104*mm(2)	볼트(L)104*mm(2)	1	
A-55	01-0118(-123D)		Washer	와셔	1	
A-56	41-0212(-100H)		Siscon Winder Lower Shaft	실리콘 하부 축	1	
A-57	41-0214(-100H)		Siscon Winder Adjusting Term	실리콘 조정 용	1	
A-58	010215(-0113)		Screw(M)104*mm(2)	볼트(M)	1	

Note: P=Heavy Material(중량재), M=Medium Material(중량재), NA=Nonmetallic Heavy Material(비금속 중량재)  
L=Light Material(저중량재), K=Soft Material(부드러운), EL=Large Shruble Piece(대 사이즈 부품)

①:관계 별 고유 코드

Unique code by mechanism

②:관계 별 고유 명칭

Unique name by mechanism

③:관계도

Explode view

④Ref.No.:파트별 고유 식별 번호

Unique identification number by part

⑤Parts No.:고유 제품 코드

Unique Product code

Ex)

구분 Category	Code	비고 remarks
구 부품 Old part	01-030C-1230	
신 부품 New Part	AS-000000-00	조(組) 파트 Set parts
	GP-000000-00	기구적 파트 Instrumental parts
	EP-000000-00	전기적 파트 Electrical parts

⑥Note:공지사항 표기 및 메모

Refers to notice and memo

⑦품

명:파트의 고유 품명

Name of Part:Unique name of parts

⑧Q'ty :파트의 수량

The number of parts

⑨Assembly no.:조(組) 파트의 식별 번호

Unique identification number by set part

# Warning

1. 조에 속한 파트는 개별 조립 시 제품의 파손 또는 재봉 불량 발생될 수 있어 해당 파트에 대한 주문 시에는 조 품목으로만 구입이 가능합니다.
2. 본 책자는 Parts Book으로 제작되었으므로 매뉴얼로 사용 불가합니다.
3. 사전 예고 없이 사양이 변경 될 수도 있습니다.

1. The parts classified as ass'y items may cause damage to the machine or bad sewing when they are separately assembled. Hence, when they are ordered, they can be purchased as ass'y items only.
2. This is a parts book. It cannot be used as a manual.
3. Parts are Subject to change in Design Without Prior Notice.

## Note

- 썬스타 제품의 부품은 아래 인터넷주소로 접속하시어 신청할 수 있습니다.  
<http://www.sunstarcs.com>
- 가입된 회원께서는 썬스타 포탈 사이트에 로그인후 필요한 부품을 신청할 수 있습니다.
- 부품관리-발주관리-발주등록 항목에서 부품번호와 신청수량을 입력하여 등록하시면 발주가 됩니다.
- 부품번호를 모르시는 경우 파츠북 조회를 클릭하시고 사용하는 기종을 검색하여 선택하시면 해당 기종의 파츠북을 조회할 수 있습니다.
- 파츠북은 관계별로 구분되어 있으며 관계를 알고 있다면 부품 찾기가 용이합니다.
  
- You can make an order for the parts of Sunstar machine to connect internet address.  
<http://www.sunstarcs.com>
- You can request for parts you want after login if you are a registered member.
- In parts Management - Order Management - Order Registration entry, you can place an order by entering the part number and quantity.
- If you don't know the parts number, click the parts book menu bar.  
In a download list, you can read parts book by searching model you use.
- This parts book is classified by the mechanism, therefore you can find part easily.

Eyelet Button Holing S/M MODEL (아일렛 단추구멍 재봉기)

SPS/D-BH6000 - 01

Sunstar Pattern System  
썬스타 패턴 시스템

Series  
시리즈

Thread Trimmer Type 사절구분  
01 : Long Trimmer 긴사절  
02 : Short Trimmer 짧은사절

Eyelet Button Holing S/M Model Name  
단추 구멍 재봉기 명

# CONTENTS

## 목 차

### I. Machine Part 기구 파트

A	Arm, Bed & Machine Body Mechanism 암, 베드 및 외장품	8
B	Upper Shaft Mechanism 상축	14
C	Needle Bar & Thread Take Up Lever Mechanism 바늘대 및 실채기 관계	16
D	Lower Mechanism 하축 관계	20
E	Upper Thread Trimmer Mechanism 상사절 관계	22
F1	Lower Thread Trimmer Mechanism (01) 하사절 관계 (01)	24
F2	Upper Thread Trimmer Mechanism (02) 상사절 관계 (02)	26
G	Zigzag Mechanism 지그재그 관계	28
H	Needle Bar Rocking Mechanism 바늘대 회동 관계	30
I	X-Y Feed Mechanism X-Y이송 관계	32
J	Presser Plate Mechanism 누름판 관계	36
J1	Presser Plate Mechanism (01) 누름판 관계 (01)	38
J2	Presser Plate Mechanism (02) 누름판 관계 (02)	40
K	Cutter Mechanism 커터 관계	42
L	Double Chain Stitch Looper Mechanism 이중환봉 관계	46
L1	Double Chain Stitch Looper Mechanism (01) 이중환봉 관계 (01)	50
L2	Double Chain Stitch Looper Mechanism (02) 이중환봉 관계 (02)	52
M	Looper & Spreader Mechanism 루퍼 및 스프레더 관계	54
N	Thread Release & Thread Tension Mechanism 실조절 장치 관계	56
O	Lubrication Mechanism 급유 관계	60
P	Pneumatic Mechanism 공압 관계	64
Q	Table & Thread Stand Mechanism 테이블 및 실패꽃이 관계	66
R	Accessories Mechanism 액세서리 관계	68
S	Hand Switch & Pedal Mechanism 핸드 스위치 및 페달 관계	70



## II. Control Part 전기 파트

T	Control Box Mechanism 컨트롤 박스 관계	●.....	72
U	Operation Unit Mechanism 오퍼레이션 유니트 관계	●.....	76

## III. Option Part 옵션 파트

V	Special Lapel Cupping Mechanism 스페셜 라펠 커팅 장치	●.....	78
W	Fly Index Mechanism 플라이 인덱서 관계	●.....	80
X	Upper Thread Nopper Mechanism 윗실 잡이	●.....	84

## IV. Gauge Part 게이지 파트

Y	Gauge 게이지	●.....	88
	Index 인덱스	●.....	92

# A

## Machine Body Mechanism

### 외장 관계

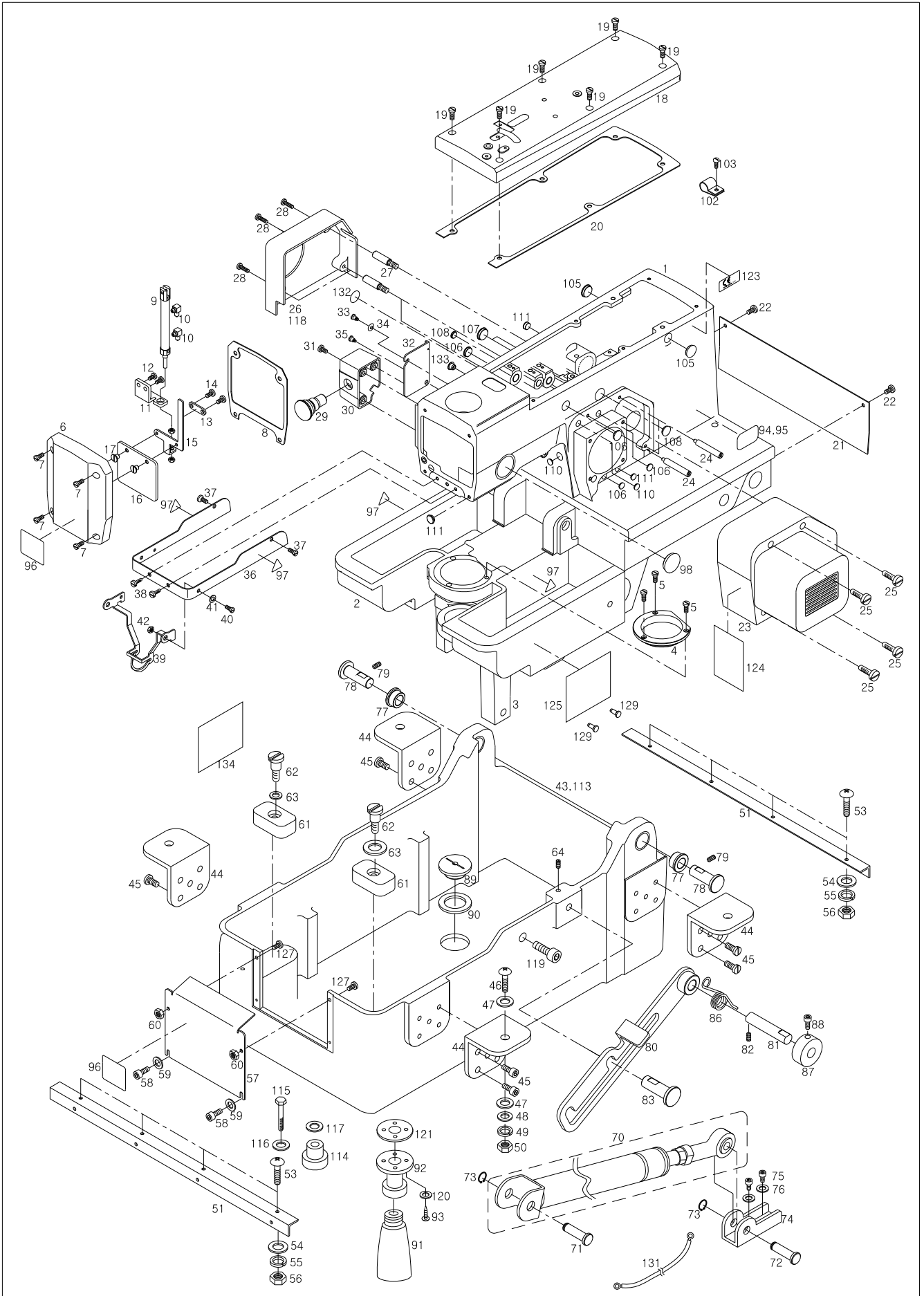





Ref. No.	Parts No.	Note	Name of Parts	품 명	Q'ty	Applied
A-1	CAB-AA001401		Arm	암	1	Dec.03.10
A-2	CAB-AB001103		Bed	베드	1	Jul.13.11
A-3	CAB-BA000101		Base	베이스	1	
A-4	GP-001680-01		Looper Base Bushing	루퍼 베이스 붓싱	1	
A-5	DSC-BJ000300		Looper Base Bushing Screw(9/64" n=40)	루퍼 베이스 붓싱 침나사(9/64" n=40)	3	
A-6	CMB-LA003700		Face Plate	면판	1	
A-7	DSC-BF001000		Screw(11/64" n=40)	면판 침나사(11/64" n=40)	4	
A-8	CMB-FC001901		Gasket For Face Plate	면판 가스켓	1	Mar.08.12
A-9	PPP-CA000700		Safety Plate Air Cylinder	안전판 에어 실린더	1	
A-10	PPP-AA000100		Safety Plate Air Cylinder Fitting	안전판 에어 실린더 피팅	2	
A-11	CMB-BB003700		Holder For Safety Plate Cylinder	안전판 실린더 홀더	1	
A-12	DSC-BF001000		Screw(11/64" n=40)	안전판 실린더 홀더 침나사(11/64" n=40)	2	
A-13	CMB-BJ002100		Cover For Safety Plate Guide	안전판 가이드 커버	1	
A-14	DSC-BJ000200		Screw(11/64" n=40)	안전판 가이드 커버 침나사(11/64" n=40)	2	
A-15	CMB-BB003600		Safety Plate Guide	안전판 가이드	1	
A-16	CMB-BJ002000		Safety Plate	안전판	1	
A-17	DSC-BB000500		Safety Plate Fixed Screw(11/64" n=40)	안전판 침나사(11/64" n=40)	2	
A-18	CMB-LA003601		Top Cover	윗뚜껑	1	
A-19	DSC-BF001000		Screw(11/64" n=40)	윗뚜껑 침나사(11/64" n=40)	6	
A-20	CMB-FC001800		Gasket For Top Cover	윗뚜껑 가스켓	1	
A-21	CMB-LB003500		Bed Cover(R)	베드 후면 커버	1	
A-22	DSC-BJ000200		Screw(11/64" n=40)	후면 커버 침나사(11/64" n=40)	2	
A-23	CMB-LA003500		Motor Cover	모터 커버	1	
A-24	DSC-HB001000		Motor Cover Support Bar	모터 커버 지지봉	3	
A-25	DSC-BF001000		Screw(11/64" n=40)	모터 커버 침나사(11/64" n=40)	4	
A-26	CMB-LA006800	-01	Cover For Gimp Thread Take-Up Lever Ass'y	심사 인출 레버(조) 커버	1	
A-27	DSC-HB000300		Cover Support Bar	심사 인출 레버(조) 커버 지지봉	3	
A-28	DSC-BA000500		Screw(3/16" n=28)	심사 인출 레버(조) 커버 침나사(3/16" n=28)	3	
A-29	GP-017451-00		Pause Switch(Ass'y)	비상스위치(조)	1	
A-30	CMB-LA003800		Cover For Emergence Stop S/W	비상스위치 커버	1	
A-31	DSC-BF001000		Screw(11/64" n=40)	비상스위치 커버 침나사(11/64" n=40)	3	
A-32	CMB-LB004500		Cover For Zigzag Adjusting Lever	지그재그 조절 레버 커버	1	
A-33	DSC-FA006100		Stud ScrewA(11/64" n=40)	지그재그 조절 레버 커버 단나사A(11/64" n=40)	1	
A-34	DWS-CC000100		Wave Washer	단나사 파형 와셔	1	
A-35	DSC-BJ002300		Stud ScrewB(9/64" n=40)	지그재그 조절 레버 커버 단나사B(9/64" n=40)	1	
A-36	CMB-LA003900		Cover For Needle Bar Timing Belt	바늘대 타이밍 벨트 커버	1	
A-37	DSC-BJ000200		Screw(11/64" n=40)	바늘대 타이밍 벨트 커버 침나사(11/64" n=40)	2	
A-38	DSC-BJ000200		ScrewB(11/64" n=40)	바늘대 타이밍 벨트 커버 침나사B(11/64" n=40)	2	
A-39	CMB-LA006700		Finger Guard	핑거 가드	1	
A-40	DSC-FA004300		Stud Screw(11/64" n=40)	핑거 가드 단나사(11/64" n=40)	2	
A-41	DWS-CC000100		Washer	단나사 와셔	2	
A-42	DSN-AA000900		Nut(11/64" n=40)	단나사 너트(11/64" n=40))	2	
A-43	CST-JA000900		Bed Base	베드 베이스	1	
A-44	CST-BB002101		Bed Base Bracket	베드 베이스 브라켓	4	Dec.19.11
A-45	PSC-AC006800		Screw(M8xL25)	베드 베이스 브라켓 침나사(M8xL25)	20	
A-46	PSC-AZ000100		Fixed Bolt(M8)	베드 베이스 브라켓 고정 볼트(M8)	4	
A-47	CST-FB000400		Fixed Bolt Support Rubber	고정 볼트 받침 고무	8	
A-48	PWS-AA001700		Washer	고정 볼트 와셔	4	
A-49	PWS-CA001500		Spring Washer	고정 볼트 스프링 와셔	4	
A-50	PSN-AA000500		Nut(M8)	고정 볼트 너트(M8)	4	
A-51	GP-000649-02		Table Support Plate	테이블 지지판	1	
A-53	PSC-AZ000100		Fixed Bolt(M8)	지지판 고정 볼트(M8)	8	
A-54	PWS-AA001700		Washer	고정 볼트 와셔	8	
A-55	PWS-CA001500		Spring Washer	고정 볼트 스프링 와셔	8	
A-56	PSN-AA000500		Nut(M8)	고정 볼트 너트(M8)	8	
A-57	CST-LB000300		Front Cover For Bed Base	베드 베이스 전면 커버	1	
A-58	PSC-AC006700		Screw(M4xL15)	베드 베이스 전면 커버 침나사(M4xL15)	2	

NOTE: 01 → Long Trimmer(긴 사절형)  
02 → Short Trimmer(짧은 사절형)

# A

## Machine Body Mechanism

### 외장 관계

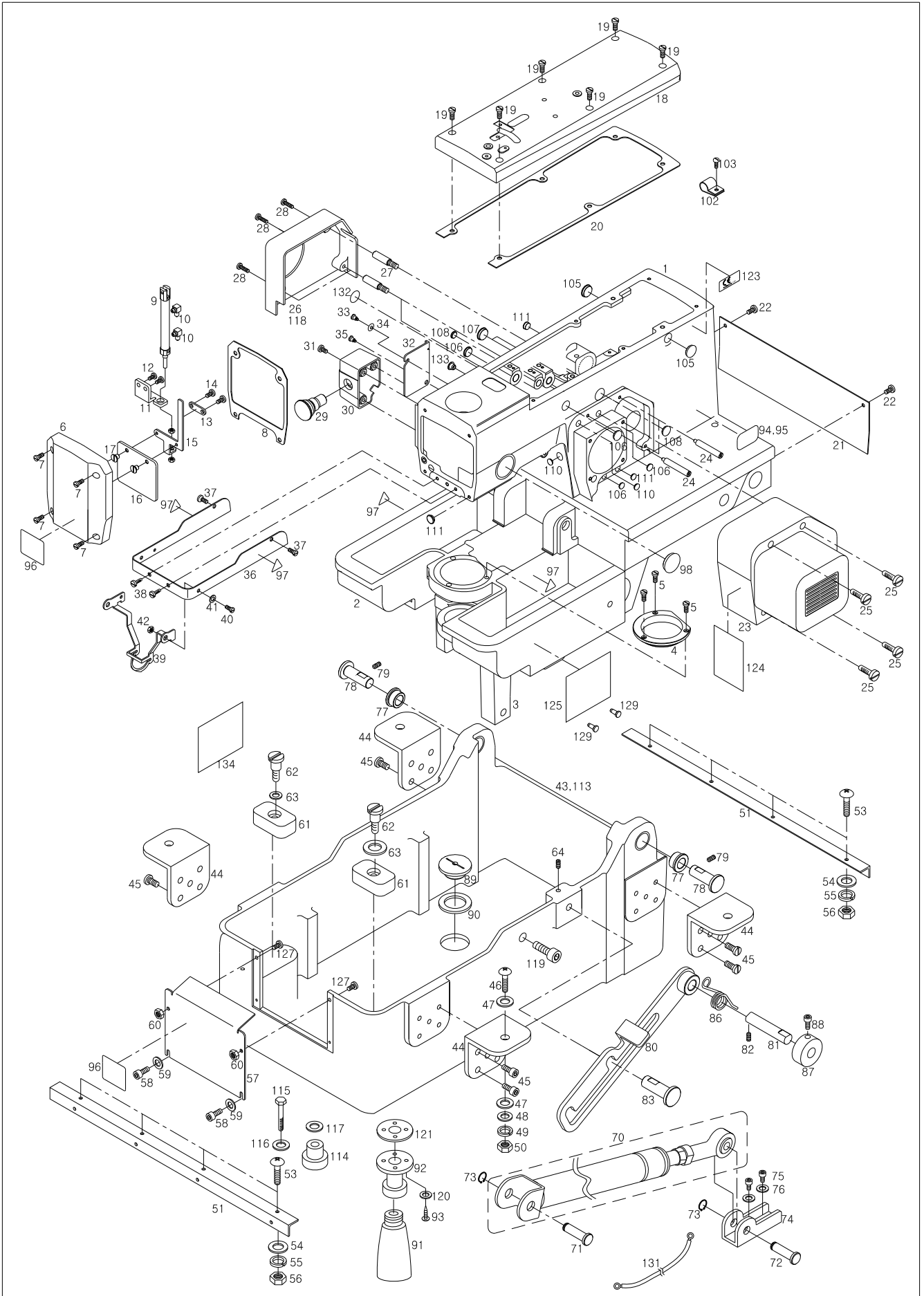



Ref. No.	Parts No.	Note	Name of Parts	품 명	Q'ty	Applied Period
A-59	PWS-AA000200		Washer	침나사 와셔	2	
A-60	PSN-AA001500		Nut(M4)	침나사 너트(M4)	2	
A-61	CST-FD001000		Rubber For Support Bed	베드 받침 고무	2	
A-62	DSC-FA004400		Stud Screw(15/64" n=28)	베드 받침 고무 단나사(15/64" n=28)	2	
A-63	PWS-AA001700		Washer	베드 받침 고무 단나사 와셔	2	
A-70	AST-PS000100		Gas Spring Ass'y For Head	헤드 지지 가스 스프링(조)	1	
A-71	DPN-AD003500		Shaft A For Gas Spring Support	가스 스프링 지지 축(A)	1	
A-72	DPN-AD003600		Shaft A For Gas Spring Support	가스 스프링 지지 축(B)	1	
A-73	PSR-AG000200		G-Ring(φ8)	지지 축 G-링(φ8)	2	
A-74	CST-BB001800		Bracket For Gas Spring Fixing	가스 스프링 고정 브라켓	1	
A-75	PSC-AC001700		Screw(M5×L10)	가스 스프링 고정 브라켓 침나사(M5×L10)	2	
A-76	DWS-AA000600		Washer	침나사 와셔	2	
A-77	DBS-DB000900		Bushing For Bed Hinge Shaft	베드 힌지 축 붓심	2	
A-78	DPN-AD002600		Bed Hinge Shaft	베드 힌지 축	2	
A-79	DSC-CA000900		Screw(15/64" n=28)	베드 힌지 축 침나사(15/64" n=28)	2	
A-80	CST-CM000102		Head Support Lever Ass'y	헤드 지지 레버(조)	1	Jul.13.10
	CST-CM000101		Head Support Lever Ass'y	헤드 지지 레버(조)	1	Apr.21.10
A-81	DPN-AA003200		Shaft A For Head Support Lever Ass'y	헤드 지지 레버 축A	1	
A-82	DSC-CB000500		Screw(15/64" n=28)	헤드 지지 레버 축A 침나사(15/64"n=28)	1	
A-83	DPN-AD003400		Shaft B For Head Support Lever Ass'y	헤드 지지 레버 축B	1	
A-84	DSC-CB000500		Screw(15/64" n=28)	헤드 지지 레버 축B 침나사(15/64"n=28)	1	
A-86	DSP-AC000500		Spring For Head Support Lever	헤드 지지 레버 스프링	1	
A-87	DCL-AA002400		Collar For Head Support Lever	헤드 지지 레버 축 카라	1	
A-88	PSC-AC001200		Screw(M6×L15)	헤드 지지 레버 축 카라 침나사(M6×L15)	1	
A-89	DSC-BF007300		Screw For Oil Support Cap	오일통 받이 마개나사	1	
A-90	CST-FB000600		Rubber Washer For Cap Screw	마개나사 고무와셔	1	
A-91	CST-JB000100		Oiler	오일 저장통	1	
A-92	CST-BA000100		Oil Support	오일통 받이	1	
A-93	PSC-AC002000		Screw(M3×L10)	오일통 받이 고정 나사(M3×L10)	4	
A-94	GP-014959-01		Model Mark(01)	모델마크(01)	1	Oct.19.10
A-95	GP-014960-01		Model Mark(02)	모델마크(02)	1	Oct.19.10
A-96	CMB-LD001700		Head Safety Warning Sticker	헤드 안전 경고 스티커	1	
A-97	01-060M-300G		Warning Sign Sticker	위험표시 스티커	4	
A-98	DPK-CB001401		Rubber Cap For Zigzag Rocker Shaft	지그재그 요동축 고무마개	1	Jul.06.11
A-102	PTC-AH000400		Code Holder(10N)	코드홀더(10N)	1	
A-103	DSC-BJ000200		Screw(4525)	코드홀더 침나사(4525)	1	
A-105	DPK-CB001500		Rubber Cap	커터 실린더 축 고무마개	2	
A-106	DPK-CB000200		Rubber Cap	바늘대 구동 레버 축 고무마개	4	
A-107	DPK-CB000700		Rubber Cap	실채기 축 고무마개	3	
A-108	DPK-CA001101		Rubber Cap	바늘대 구동 레버핀 고무마개	2	Jul.06.11
A-110	DPK-CB000700		Rubber Cap	커플링 고무마개	1	
A-111	DPK-CB001800		Rubber Cap E	링크축 C 고무마개	3	
A-113	GP-002170-00		Bed Base(T) (Option)	베드 베이스(T) (옵션)	1	
A-114	GP-002171-00		Bed Base Support Rubber (Option)	베드 베이스 받침 고무 (옵션)	4	
A-115	SC-000055-00		Bed Base Fixing Bolt (Option)	베드 베이스 고정 볼트 (옵션)	4	
A-116	PWS-AA001700		Fixing Bolt Washer (Option)	고정 볼트 와셔 (옵션)	4	
A-117	10-043R-9577		Fixing Bolt Rubber Washer (Option)	고정 볼트 고무 와셔 (옵션)	4	
A-118	GP-002379-00		Cover For Gimp Thread Take-up Lever Ass'y-B	심사인출레버(조)커버-B	1	
A-119	PSC-AC006800		Bed Fixing Bolt	베드 고정 볼트	1	
A-120	PWS-AA001900		Washer	오일통받이 고정나사 와셔	4	
A-121	CST-FB000500		Oiler Support Rubber Cap	오일통받이 고무마개	1	
A-123	GP-018205-00		CE Mark	CE 마크	1	
A-124	GP-019627-00		Upper Thread Sticker	윗실 스티커	1	
A-125	GP-019628-00		Lower Thread Sticker	밑실 스티커	1	
A-127	PSC-AC007100		Screw(M4×L10)	베드 베이스 전면 커버 침나사(M4×10)	2	
A-129	01-035P-7400		Pin	번호판 핀	4	
A-131	CA-000730-00		Cable	접지 케이블	1	

NOTE: 01 → Long Trimmer(긴 사절형)  
02 → Short Trimmer(짧은 사절형)

# A

## Machine Body Mechanism

### 외장 관계

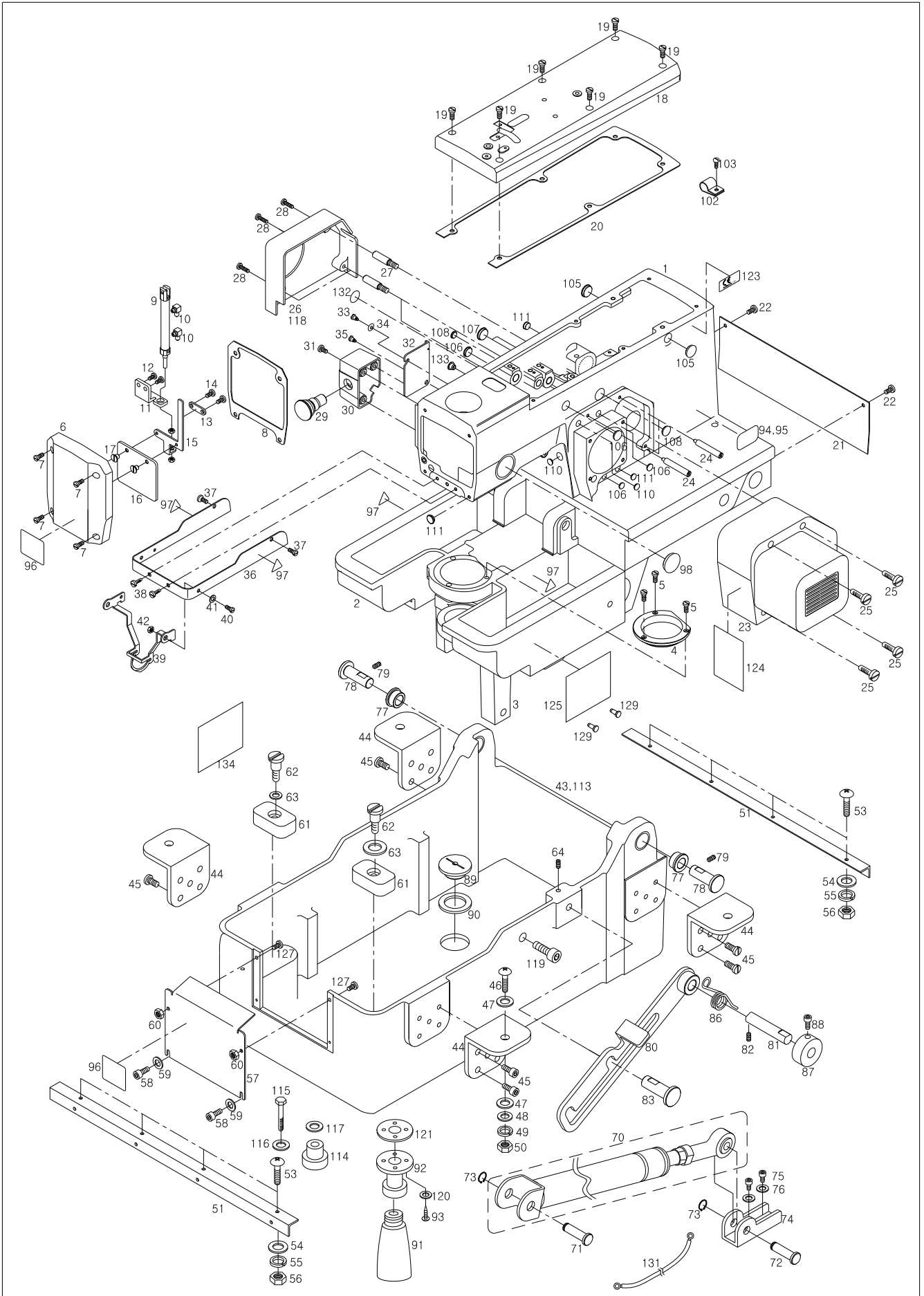



# B

## Upper Shaft Mechanism

### 상축 관계

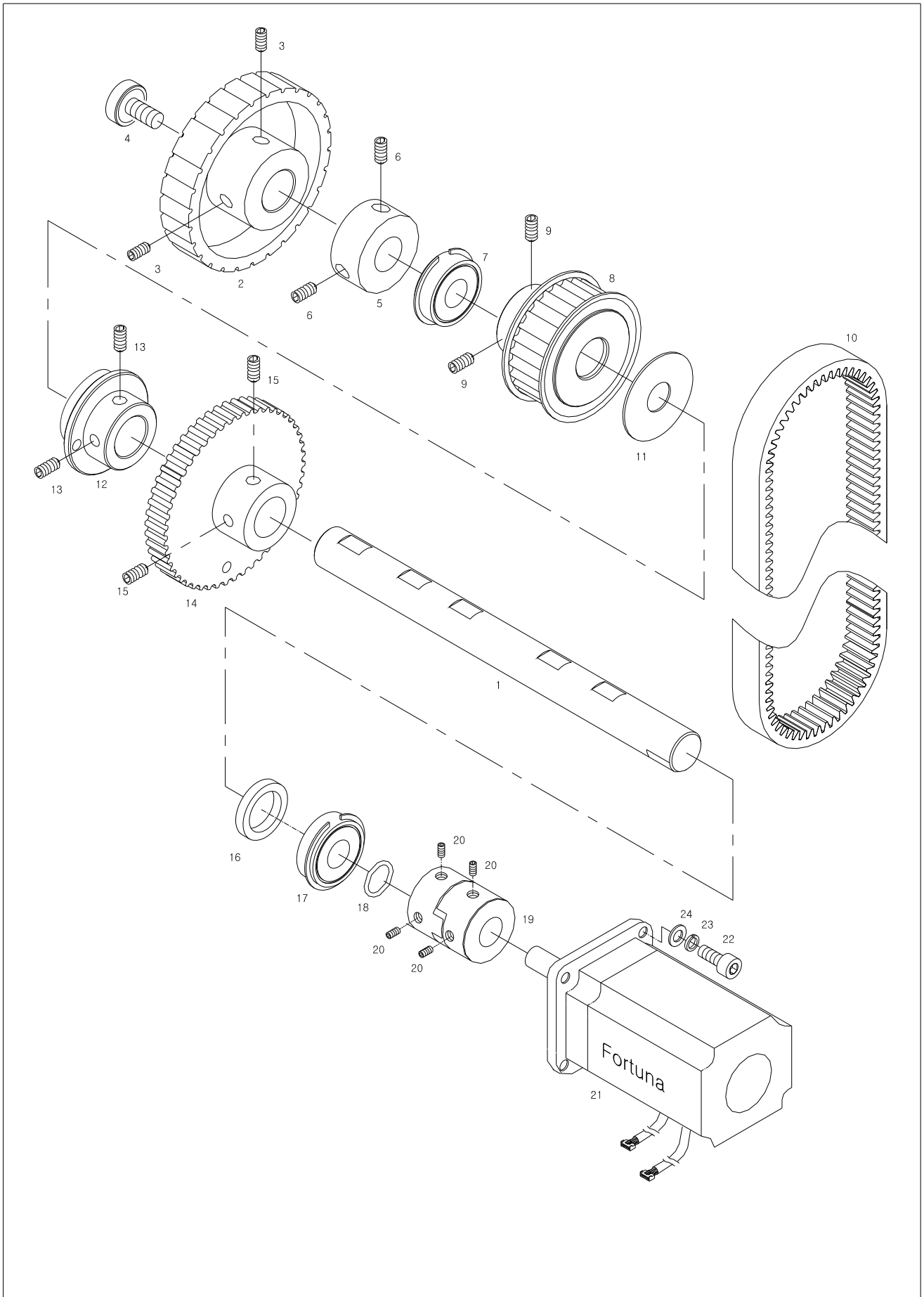



# C

## Needle Bar & Thread Take Up Lever Mechanism

### 바늘대 및 실채기 관계

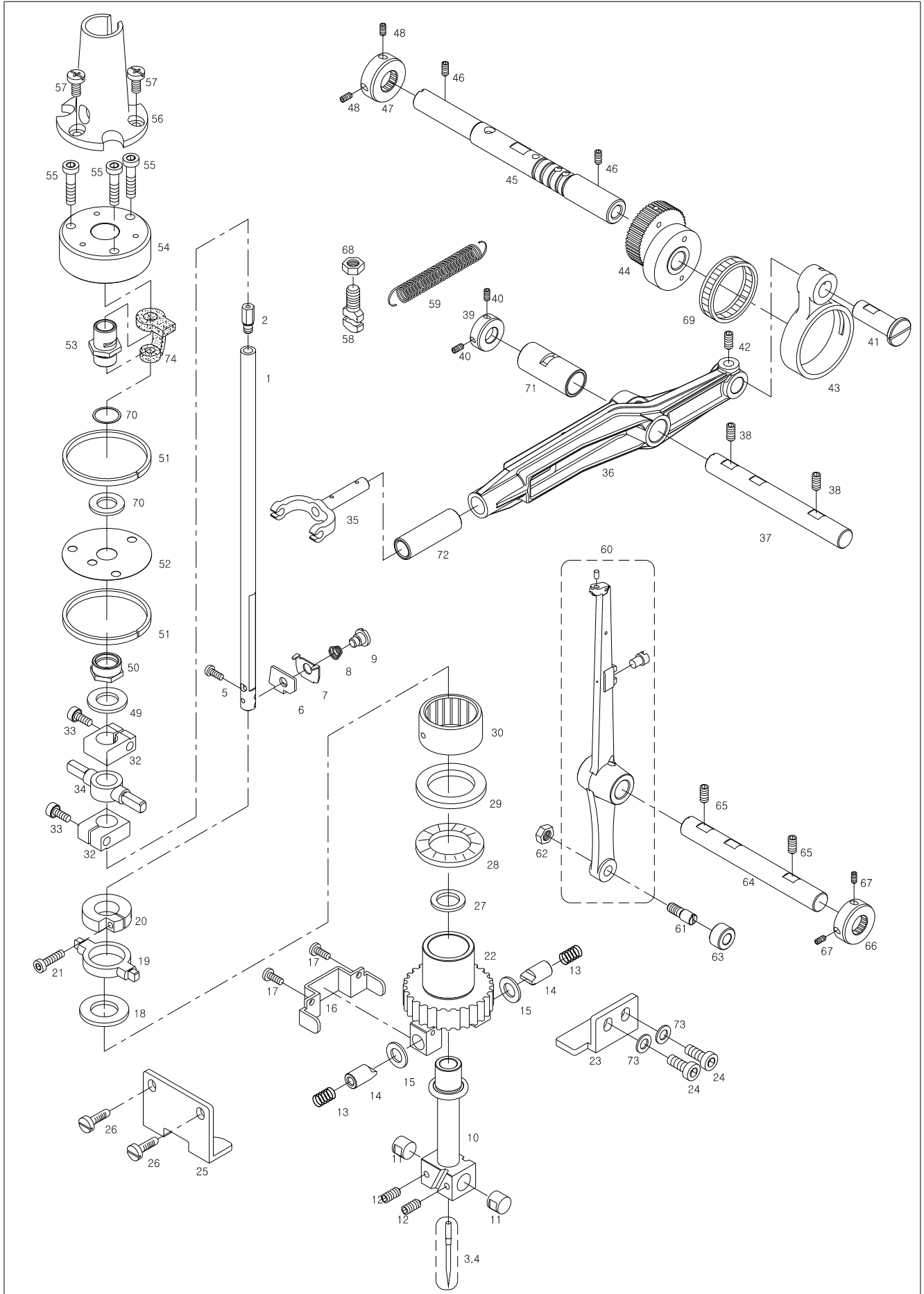



Ref. No.	Parts No.	Note	Name of Parts	품 명	Q'ty	Assembly
C-1	CNB-KA000600		Needle Bar	바늘대	1	
C-2	CNB-HK000700		Needle Bar Thread Guide	바늘대 실안내	1	
C-3	-	-01	Needle	바늘(Do×558 #14 (SCHMETZ Nm90))	1	
C-4	-	-02	Needle	바늘(Do×558 #18 (SCHMETZ Nm110))	1	
C-5	DSC-BF000100		Screw (1/8" n=44)	바늘 침나사 (1/8" n=44)	1	
C-6	CNB-HK000800		Thread Guide Plate A	실 가이드판 A	1	
C-7	CNB-HK001000		Thread Guide Plate B	실 가이드판 B	1	
C-8	DSP-BA000800		Spring For Thread Guide Plate	실 가이드판 스프링	1	
C-9	DSC-FD000400		Stud Screw For Thread Guide Plate	실가이드판 단나사	1	
C-10	CNB-CR000100		Needle Bar Block	바늘대 블록	1	
C-11	DPN-AA003300		Pin For Needle Bar Guide	바늘대 가이드핀	2	
C-12	PSC-CB000200		Screw (M4×L4)	바늘대 가이드핀 고정나사 (M4×L4)	2	
C-13	DSP-AA002600		Spring For Needle Bar Guide	바늘대 가이드 스프링	2	
C-14	CNB-CN000100		Needle Bar Guide	바늘대 가이드	2	
C-15	DWS-AA006100		Washer B For Needle Bar Block	바늘대 블록 와셔 B	2	
C-16	CNB-BJ000400		Support Plate For Needle Bar Guide	바늘대 가이드 지지판	1	
C-17	PSC-BA000500		Screw (M3×L6)	바늘대 가이드 지지판 고정나사 (M3×L6)	2	
C-18	DWS-AA006000		Washer A For Needle Bar Block	바늘대 블록 와셔 A	1	
C-19	CNB-CA000200		Zigzag Feed Link	지그재그 피드링크	1	
C-20	DCL-AC000100		Collar For Needle Bar Block	바늘대 블록 카라	1	
C-21	PSC-AC007300		Screw (M3×L12)	바늘대 블록 카라 침나사(M3×L12)	1	
C-22	DPL-BC000500		Needle Bar Driven Pulley	바늘대 종동 풀리	1	
C-23	CNB-BB000200		Support B For Needle Bar Driven Pulley	바늘대 종동 풀리 지지대 B	1	
C-24	PSC-AC000800		Screw (M4×L8)	바늘대 종동 풀리 지지대 B 고정나사 (M4×L8)	2	
C-25	CNB-BB000100		Support A For Needle Bar Driven Pulley	바늘대 종동풀리 지지대 A	1	
C-26	DSC-BF001000		Screw (11/64" n=40)	바늘대 종동풀리 지지대 A 고정나사 (11/64" n=40)	2	
C-27	CLB-JL002600		Needle Bar Felt (L)	바늘대 헬트 (하)	1	
C-28	PBR-BB000200		Trust Bearing	트러스트 베어링 (AXK 2542)	1	
C-29	PWS-AA002000		Trust Bearing Washer	트러스트 베어링 와셔 (AS 2542)	1	
C-30	PBR-BA001400		Bearing for Needle Bar Driven Pulley	바늘대 종동 풀리 베어링 (TA 2520)	1	
C-32	CNB-BF000600		Clamp For Needle Bar	바늘대 클램프	2	
C-33	PSC-AC007000		Screw (M3 × L12)	바늘대 클램프 침나사 (M3×L12)	2	
C-34	CNB-CA000100		Needle Bar Feed Link	바늘대 피드링크	1	
C-35	CNB-CA000300		Needle Bar Yoke Link	바늘대 연결링크	1	
C-36	CNB-CM000101		Needle Bar Driving Lever	바늘대 구동레버	1	
C-37	CNB-KC000200		Shaft For Needle Bar Driving Lever	바늘대 구동레버축	1	
C-38	DSC-CB000500		Screw (15/64" n=28)	바늘대 구동레버축 침나사 (15/64" n=28)	2	
C-39	DCL-AA002300		Collar For Needle Bar Driving Lever	바늘대 구동레버축 카라	1	
C-40	DSC-CB000400		Screw (1/4" n=40)	바늘대 구동레버축 카라 침나사 (1/4" n=40)	2	
C-41	DPN-AD003700		Pin For Needle Bar Driving Lever	바늘대 구동레버핀	1	
C-42	DSC-CB000500		Screw (15/64" n=28)	바늘대 구동레버핀 침나사 (15/64" n=40)	1	
C-43	CNB-CC000201		Needle Bar Driving Rod Ass'y	바늘대 구동 로드(조)	1	
C-44	ANB-PS000101		Needle Bar Driving Gear Ass'y	바늘대 구동기어(조)	1	
C-45	CNB-KH000100		Shaft For Needle Bar Driving Gear	바늘대 구동기어축	1	
C-46	DSC-CB000500		Screw (15/64" n=28)	바늘대 구동기어축 침나사 (15/64" n=28)	2	
C-47	DCL-AA001900		Collar For Needle Bar Driving Gear Shaft	바늘대 구동기어축 카라	1	
C-48	DSC-CB000400		Screw (15/14" n=28)	바늘대 구동기어축 카라 침나사 (1/4" n=40, L=6)	2	
C-49	CLB-JL002500		Needle Bar Felt (U)	바늘대 헬트 (상)	1	
C-50	DSN-CY000300		Nut For Needle Bar Bush	바늘대 상붓싱너트	1	
C-51	CNB-BN000100		Ring For Needle Bar Bush(U)	바늘대 상붓싱링	2	
C-52	DSP-AD001100		Spring Plate For Needle Bar	바늘대 스프링판	1	
C-53	DBS-DB001800		Needle Bar Bush(U)	바늘대 상붓싱	1	
C-54	CNB-BF000500		Holder For Needle Bar Bush(U)	바늘대 상붓싱 홀더	1	
C-55	PSC-AC006900		Screw (M4×L30)	바늘대 상붓싱 홀더 침나사(M4×L30)	3	
C-56	CNB-LA000100		Needle Bar Guard	바늘대 가드	1	
C-57	DSC-BJ000300		Screw (9/64" n=40)	바늘대 가드 침나사 (9/64" n=40, L=10)	3	
C-58	DSC-HD000400		Hook for Thread Take Up Lever Return Spring	실채기 복귀 스프링 걸이	1	

NOTE: 01 → Long Trimmer(긴 사절형)  
02 → Short Trimmer(짧은 사절형)

# C

## Needle Bar & Thread Take Up Lever Mechanism

### 바늘대 및 실채기 관계

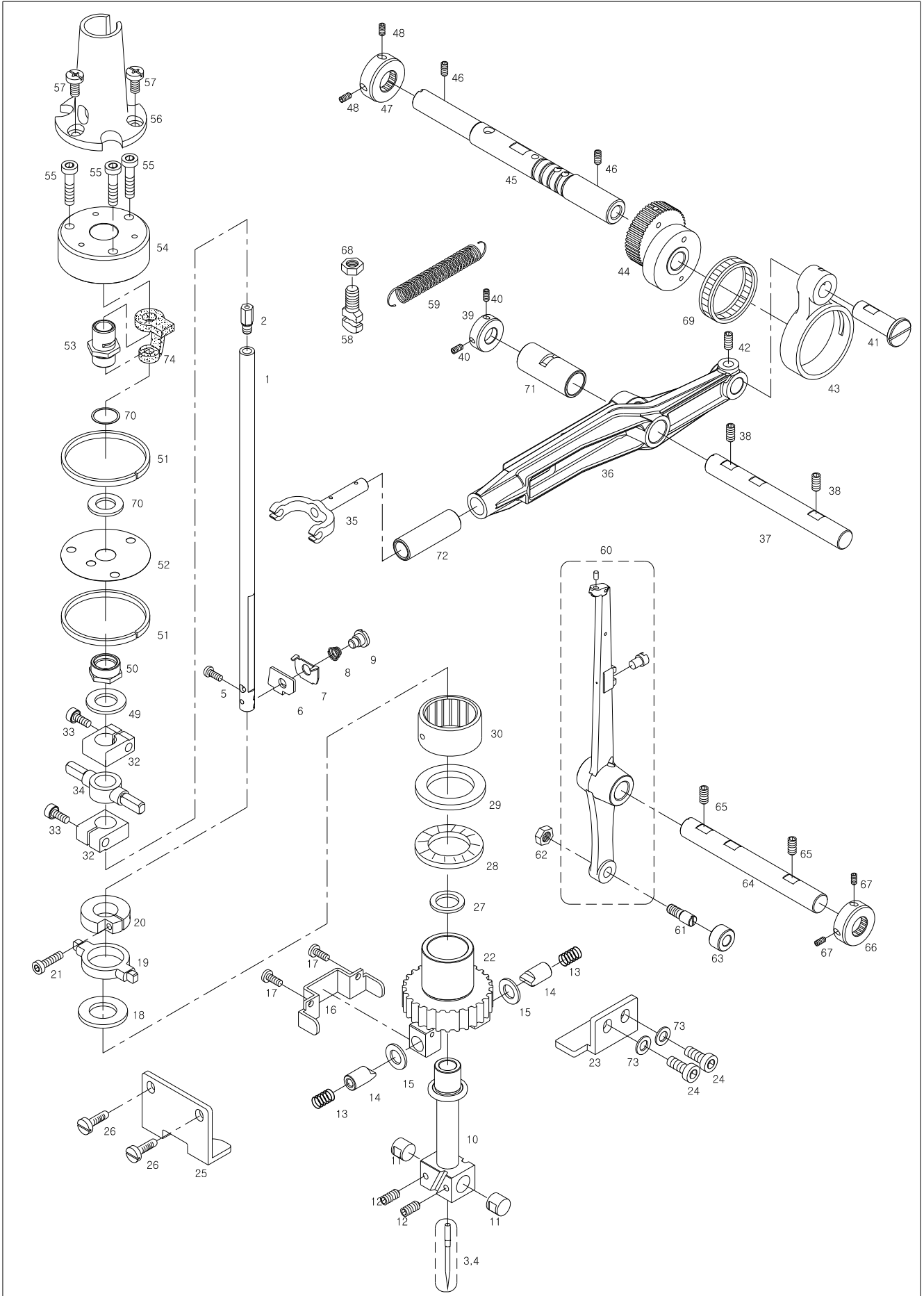



# D

## Lower Mechanism

### 하축 관계

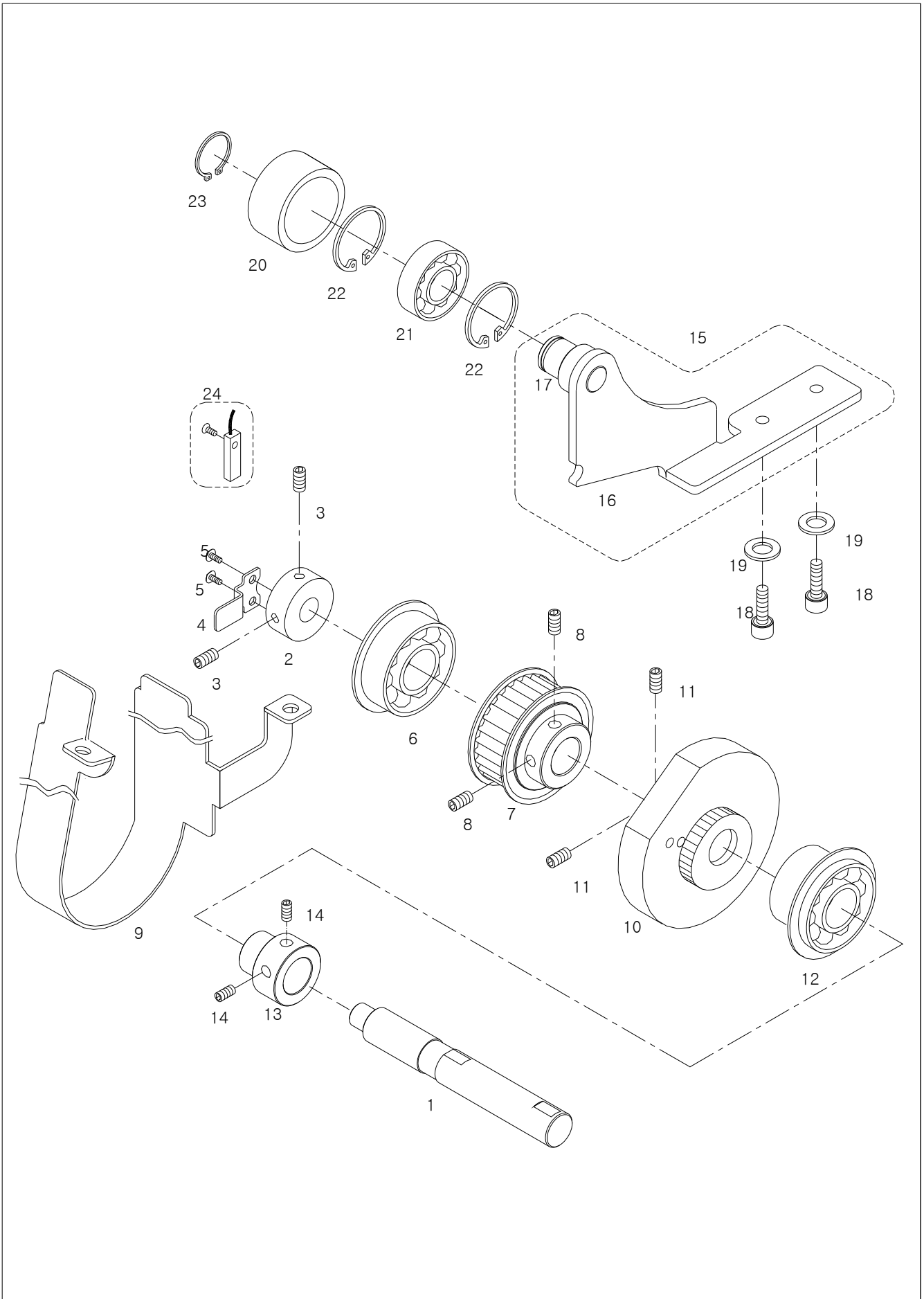



Ref. No.	Parts No.	Note	Name of Parts	품명	Q'ty	Assembly
D-1	CLS-KF000200		Lower Shaft	하축	1	
D-2	DCL-AA001600		Lower Shaft Collar	하축 카라	1	
D-3	DSC-CB000700		Screw(M5×L6)	하축 카라 잠나사 (M5×L6)	2	
D-4	CLS-BJ000101		Lower Shaft Sensor Plate	하축 센서판	1	
D-5	DSC-BF000100		Screw (1/8" n=44, L=5)	하축 센서판 고정나사 (1/8" n=44, L=5)	2	
D-6	PBR-AA001300		Lower Shaft Bearing(F)	하축 전 베어링 (6202 ZZNR)	1	
D-7	DPL-BC000400		Pulley For Lower Shaft	하축 타이밍 풀리	1	
D-8	DSC-CB000400		Screw (1/4" n=40)	하축 타이밍 풀리 잠나사 (1/4" n=40)	2	
D-9	CLS-LA000100		Cover For Lower Shaft Pulley	하축 타이밍 풀리 커버	1	
D-10	CLS-DG000100		Lower Shaft Cam	하축 캠	1	
D-11	DSC-CB000400		Screw (1/4" n=40)	하축 캠 잠나사 (1/4" n=40)	2	
D-12	PBR-AA002200		Lower Shaft Bearing(R)	하축 후 베어링 (6003 ZZNR)	1	
D-13	DCL-AB000700		Rear Bearing Bushing For Lower Shaft	하축 후 베어링 붓싱	1	
D-14	DSC-CB000500		Screw (15/64" n=28)	하축 후 베어링 붓싱 잠나사 (15/64" n=28)	2	
D-15	CLS-BB000100		Idler(Ass'y)	아이들러 (조)	1Set	D-15
D-16	GP-001086-00		Bracket For Idler	아이들러 브라켓	1	
D-17	GP-001083-01		Shaft For Idler	아이들러 축	1	
D-18	PSC-AC001300		Screw(M5×L20)	아이들러(조) 잠나사 (M5×L20)	2	
D-19	PWS-AA000400		Washer	아이들러(조) 와셔	2	
D-20	CLS-CG000100		Idler For Upper Shaft Timing Belt	상축 타이밍 벨트 아이들러	1	
D-21	PBR-AA003000		Idler Bearing	아이들러 베어링(6001 ZZ)	1	
D-22	PSR-AB000600		C-Ring(φ28)	C형 멈춤링 (φ28)-구멍용	2	
D-23	PSR-AA000300		C-Ring(φ12)	C형 멈춤링 (φ12)-축용	1	
D-24	CA-005124-00		Lower Shaft Sensor(Ass'y)	하축 센서(조)	1	

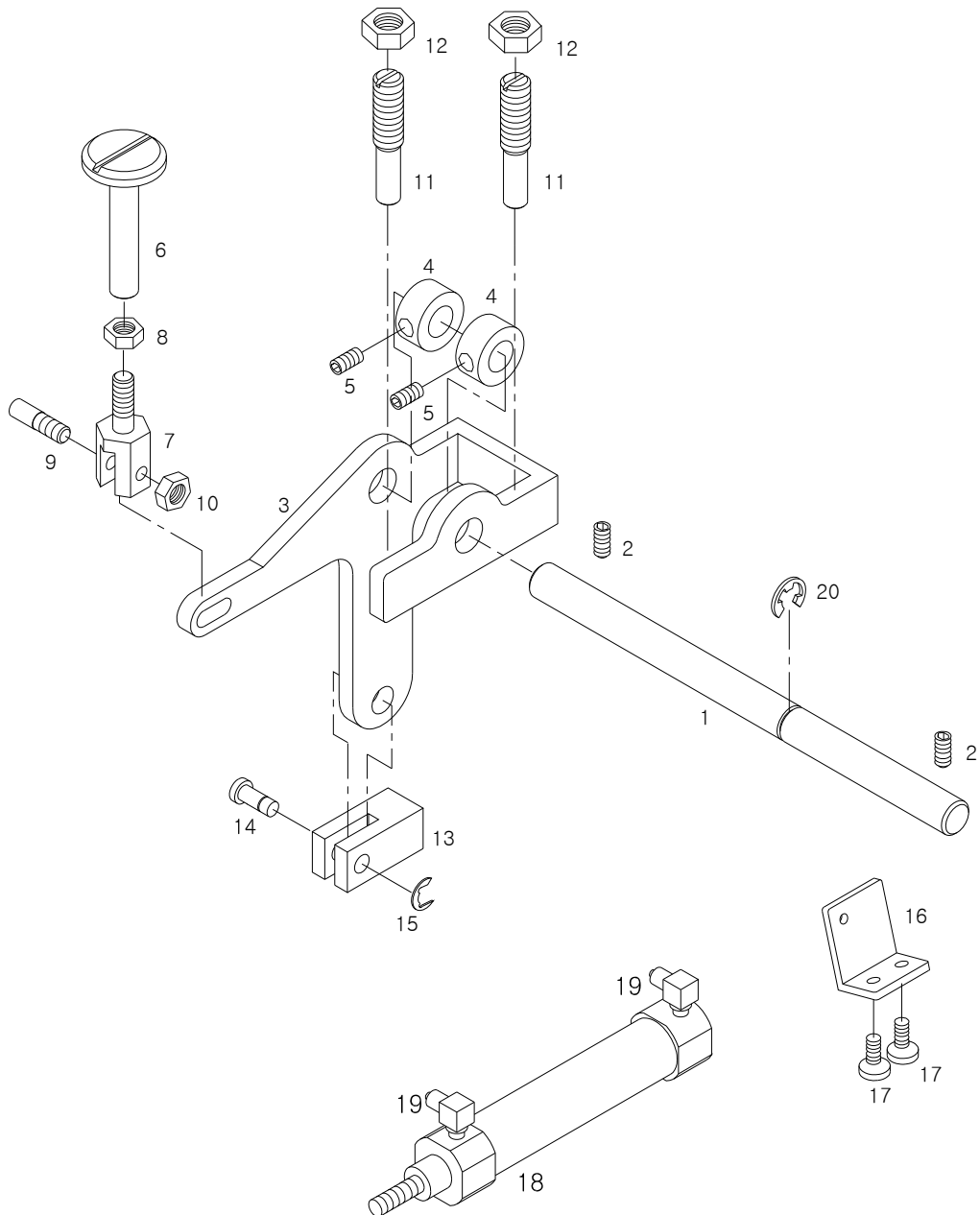



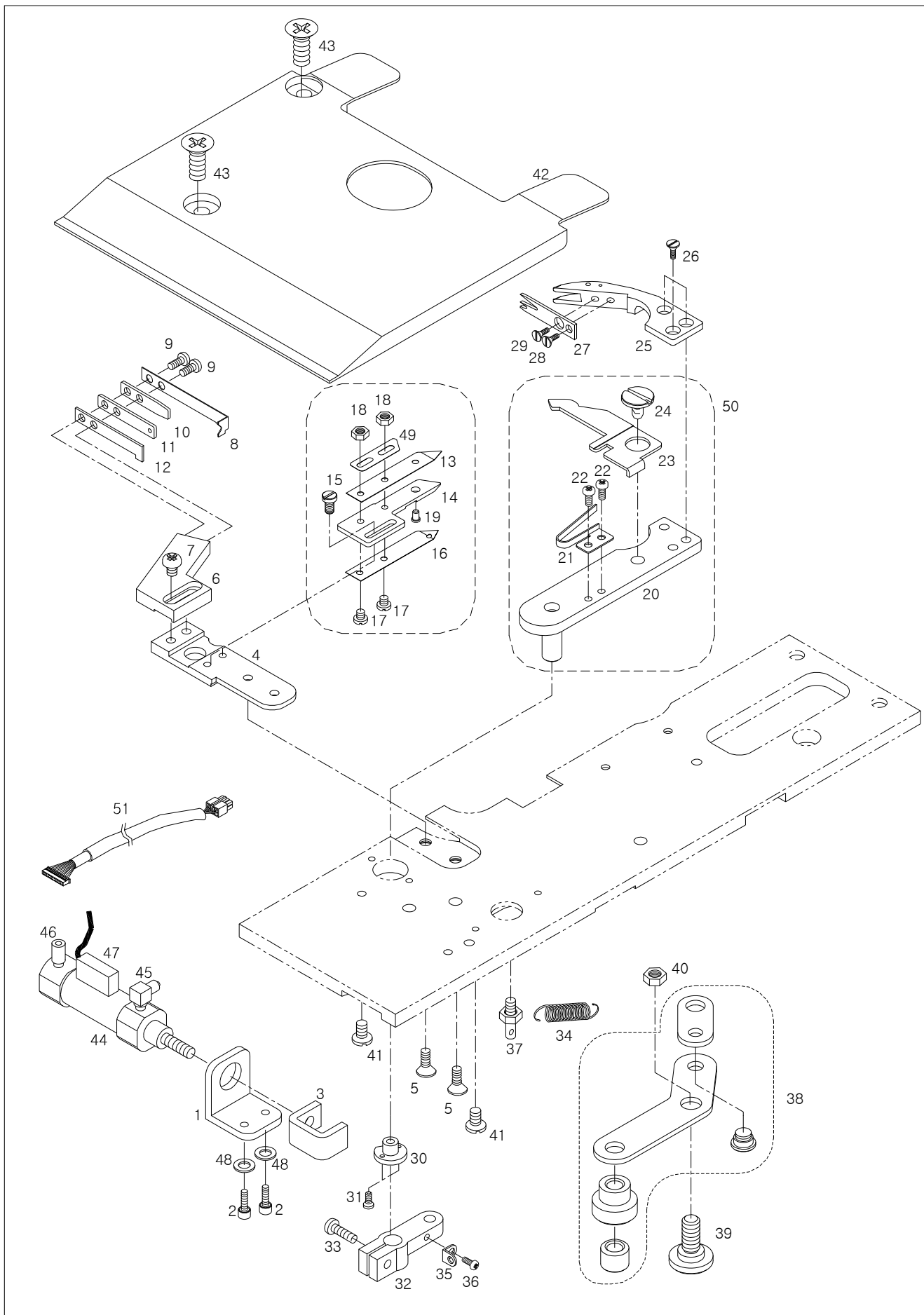





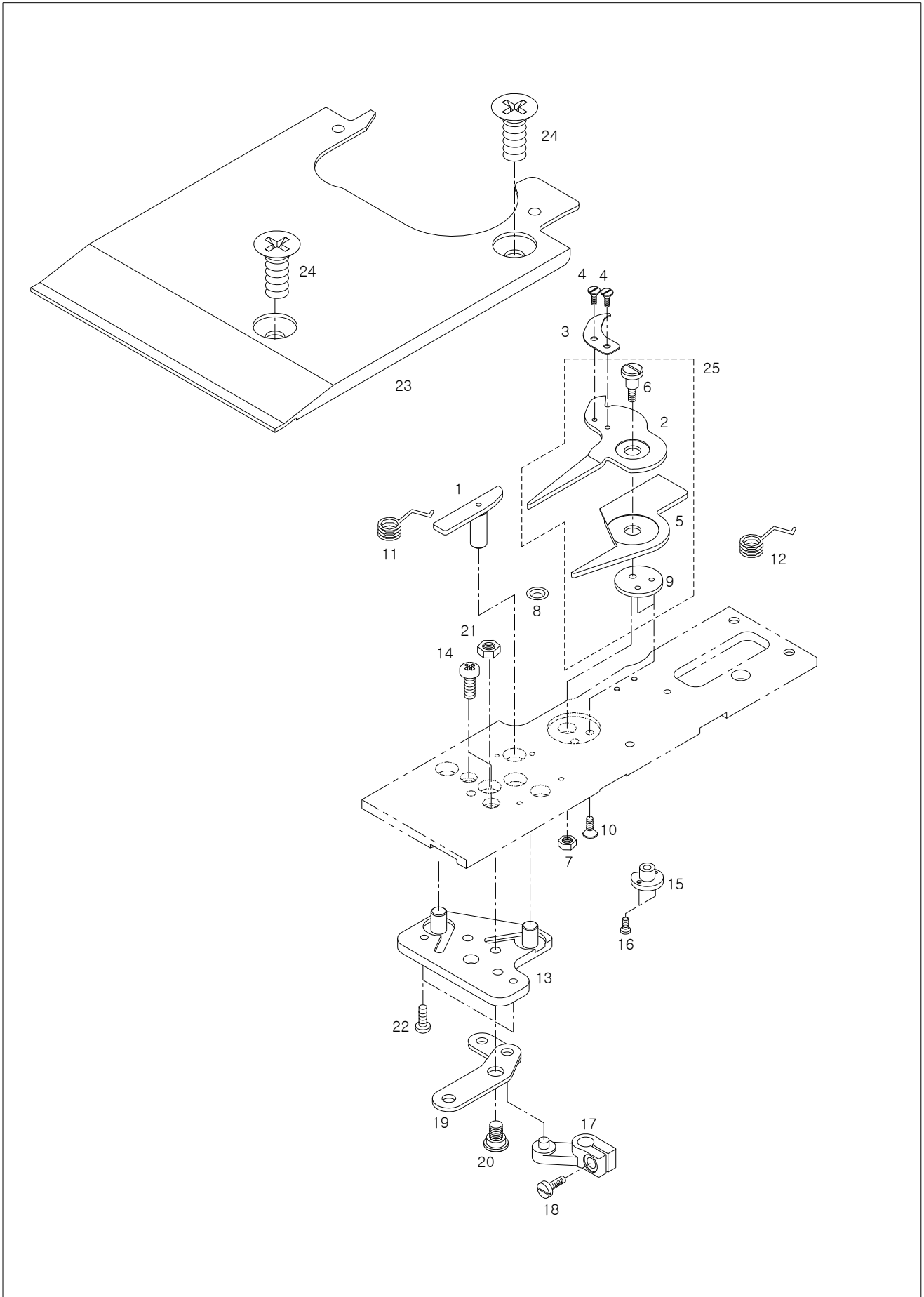



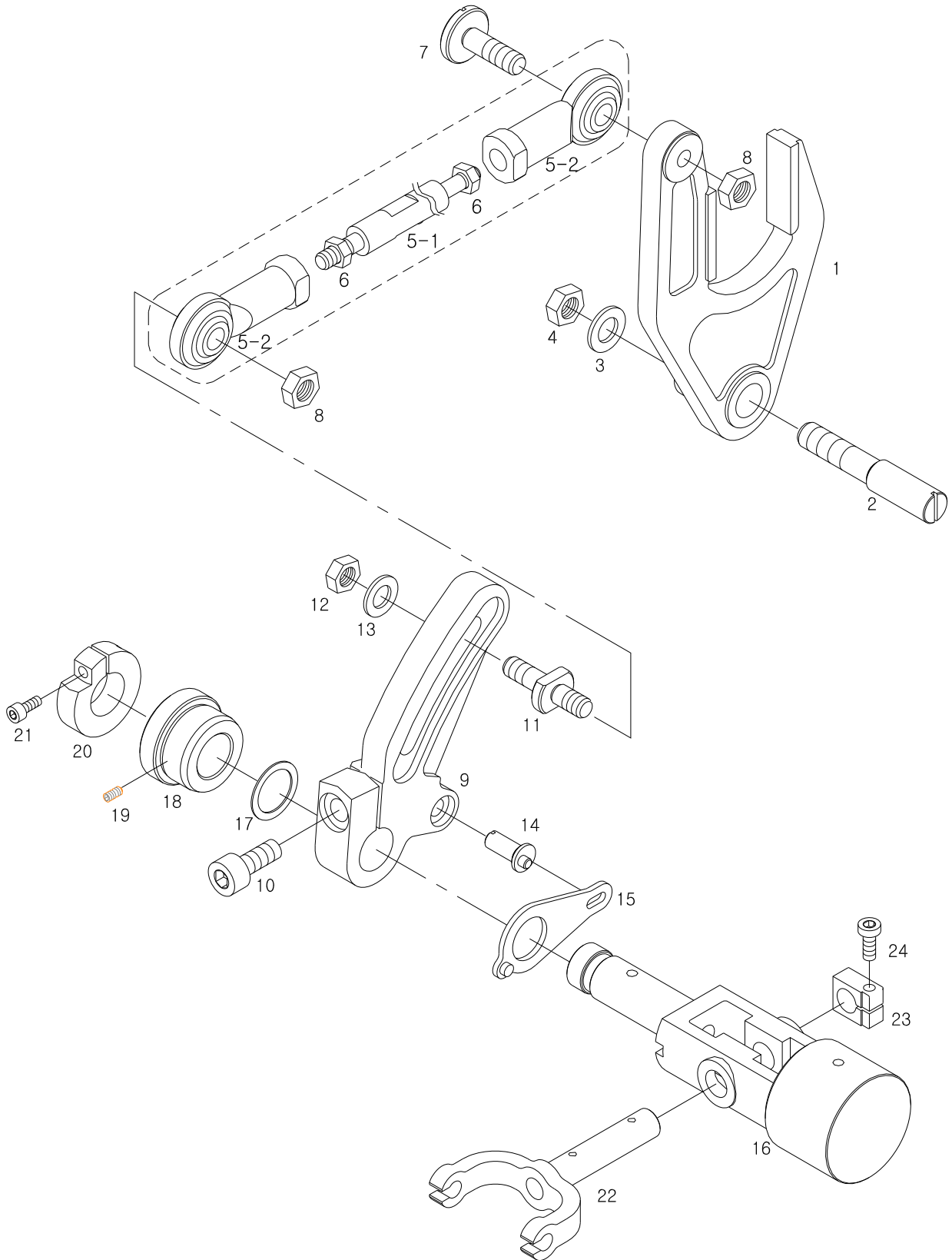



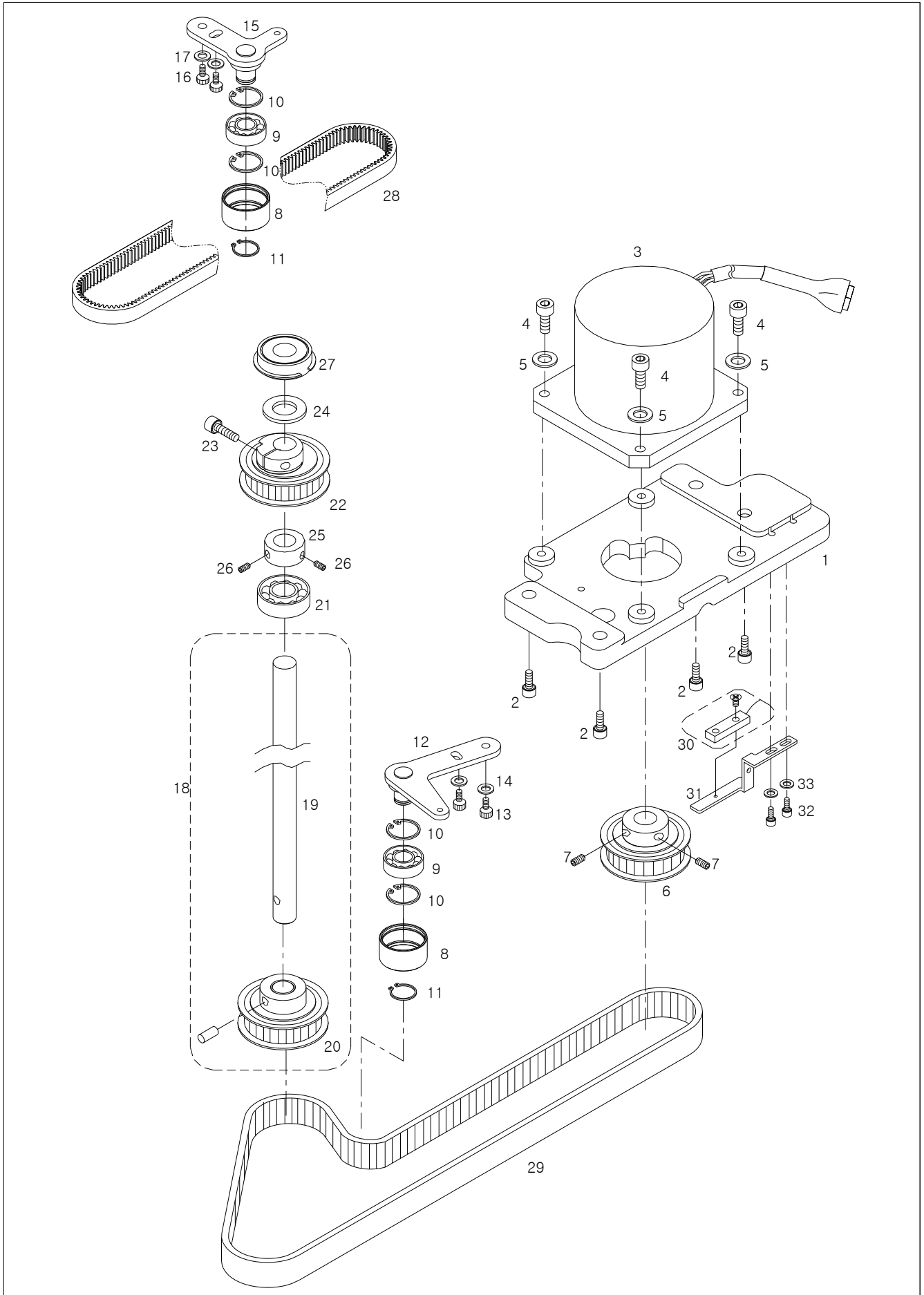



# X-Y Feed Mechanism

## X-Y 이송 관계

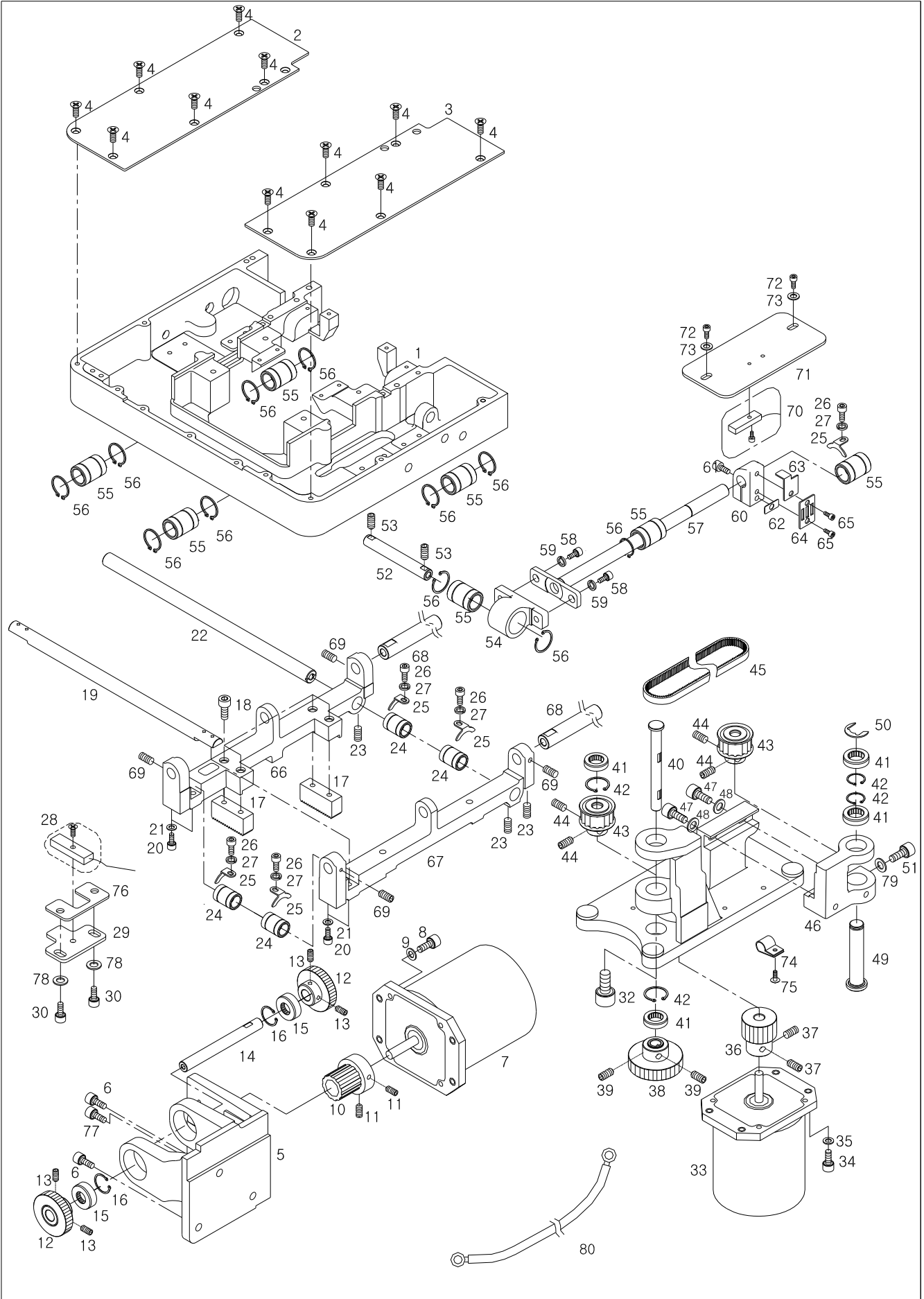





Ref. No.	Parts No.	Note	Name of Parts	품 명	Q'ty	Applied
I-1	CXF-BA001500		X-Y Feed Base	X-Y 이송 베이스	1	
I-2	CXF-LB000100		Feed Base Cover(L)	이송 베이스 커버(좌)	1	
I-3	CXF-LB000200		Feed Base Cover(R)	이송 베이스 커버(우)	1	
I-4	DSC-BB001800		Screw(11/64" n=40)	커버 첩나사(11/64" n=40)	12	
I-5	CXF-BB001300		X-Motor Base	X-모터 베이스	1	
I-6	PSC-AC000600		Screw(M6×L20)	모터 베이스 고정나사(M6×L20)	2	
I-7	PMT-BH000600		X-Feed Motor	X-이송 모터	1	
I-8	PSC-AC006700		Screw(M4×L10)	모터 고정나사(M4×L10)	4	
I-9	PWS-AA000200		Washer	고정나사 와셔	4	
I-10	DGR-AA002000		X-Driving Gear	X-구동 기어	1	
I-11	DSC-CB000500		Screw(15/64" n=28)	구동 기어 첩나사(15/64" n=28)	2	
I-12	DGR-AA002300		X-Driven Gear(Ass'y)	X-종동기어(조)	2	
I-13	DSC-CB000500		Screw (15/64" n=28)	X-종동기어 첩나사(15/64" n=28)	4	
I-14	CXF-KD000100		X-Driven Gear Shaft	X-종동기어 축	1	
I-15	PBR-AA003000		Bearing	종동기어 축 베어링(6001ZZ)	2	
I-16	PSR-AB000600		C-Ring(φ28)	종동기어 축 C-링(φ28)-구멍용	2	
I-17	DGR-AF000700		X-Feed Rack Gear	X-이송 랙 기어	2	
I-18	PSC-AC006100		Screw(M5×L15)	X-이송 랙 기어 첩나사(M5×L15)	4	
I-19	CXF-KC000700		X-Feed Guide Shaft A	X-이송 가이드 축 A	1	
I-20	PSC-AC006700		Screw(M4×L15)	가이드 축 A 첩나사(M4×L15)	4	
I-21	DWS-AA001100		Washer	가이드 축 A 첩나사 와셔	4	
I-22	CXF-KD000200		X-Feed Guide Shaft B	X-이송 가이드 축 B	1	
I-23	DSC-CB000400		Screw (1/4" n=40)	X-이송 가이드 축 B 첩나사(1/4" n=40)	3	
I-24	PBR-FA000700		X-Feed Liner Bush	X-이송 리니어 붓싱(LM12)	4	
I-25	CYF-BJ002800		Liner Bush Stopper	리니어 붓싱 스토퍼	5	
I-26	DSC-AC000500		Screw(M3×L6)	스토퍼 첩나사(M3×L6)	5	
I-27	PWS-CA000100		Spring Washer	첩나사 스프링 와셔	5	
I-28	CA-005121-00		X-Feed Sensor	X-이송 센서(조)	1	
I-29	CXF-BJ002401		X-Feed Sensor Bracket	X-이송 센서 브라켓	1	
I-30	PSC-AC000200		Screw(M4×L8)	X-이송 센서 브라켓 첩나사(M4×L8)	2	
I-31	CYF-BB001500		Y-Motor Base	Y-모터 베이스	1	
I-32	PSC-AC000600		Screw(M6×L20)	모터 베이스 첩나사(M6×L20)	4	
I-33	PMT-BH000500		Y-Feed Motor	Y-이송 모터	1	
I-34	15015SC-7113		Screw(M4×L10)	모터 고정나사(M4×L10)	4	
I-35	PWS-AA000200		Washer	고정나사 와셔	4	
I-36	DGR-AA002100		Y-Driving Gear	Y-구동 기어	1	
I-37	DSC-CB000400		Screw(15/64" n=40)	구동 기어 첩나사(15/64" n=28)	2	
I-38	DGR-AA002201		Y-Driven Gear	Y-종동 기어	1	Jun.03.11
I-39	DSC-CB000400		Screw(15/64" n=28)	종동 기어 첩나사(15/64" n=28)	2	
I-40	CYF-KC001001		Y-Timing Pulley Shaft A	Y-타이밍 풀리 축 A	1	Feb.27.12
I-41	PBR-AA003700		Bearing	Y-타이밍 풀리 축 베어링(L-1680ZZ)	4	
I-42	PSR-AB000800		C-Ring(φ16)	Y-타이밍 풀리 축 C-링(φ16, 구멍용)	4	
I-43	DPL-BF000100		Y-Feed Timing Pulley	Y-이송 타이밍 풀리	2	
I-44	DSC-CB000400		Screw(1/4" n=40)	Y-이송 풀리 첩나사(1/4" n=40)	4	
I-45	PBT-BF000100		Y-Feed Timing Belt	Y-이송 타이밍 벨트	1	
I-46	CYF-BB001601		Y-Feed Pulley Support	Y-이송 풀리 지지대	1	
I-47	PSC-AC006100		Screw(M5×L15)	지지대 첩나사(M5×L15)	2	
I-48	DWS-AA000600		Washer	첩나사 와셔	2	
I-49	CYF-KC001100		Y-Timing Pulley Shaft B	Y-타이밍 풀리 축 B	1	
I-50	PSR-AC000500		E-Ring(φ6)	Y-타이밍 풀리 축 B E-링(φ6)	1	
I-51	PSC-AC006100		Tension Adjusting Screw(M5×L20)	Y-이송 타이밍 벨트 장력 조정 나사(M5×L20)	1	
I-52	CYF-KC001301		Y-Guide Shaft	Y-가이드 축	1	
I-53	DSC-CB000700		Screw(M5)	가이드 축 첩나사(M5)	2	
I-54	CYF-BB001700		Y-Guide Shaft Holder	Y-가이드 축 홀더	1	
I-55	PBR-FA000800		Y-Feed Liner Bush	Y-이송 리니어 부시(LM10)	7	
I-56	PSR-AA000600		C-Ring(φ19)	볼 베어링 C-링(φ19)-축용	11	
I-57	AYF-PS000400		Y-Feed Shaft Ass'y	Y-이송 축(조)	1	

# X-Y Feed Mechanism

## X-Y 이송 관계

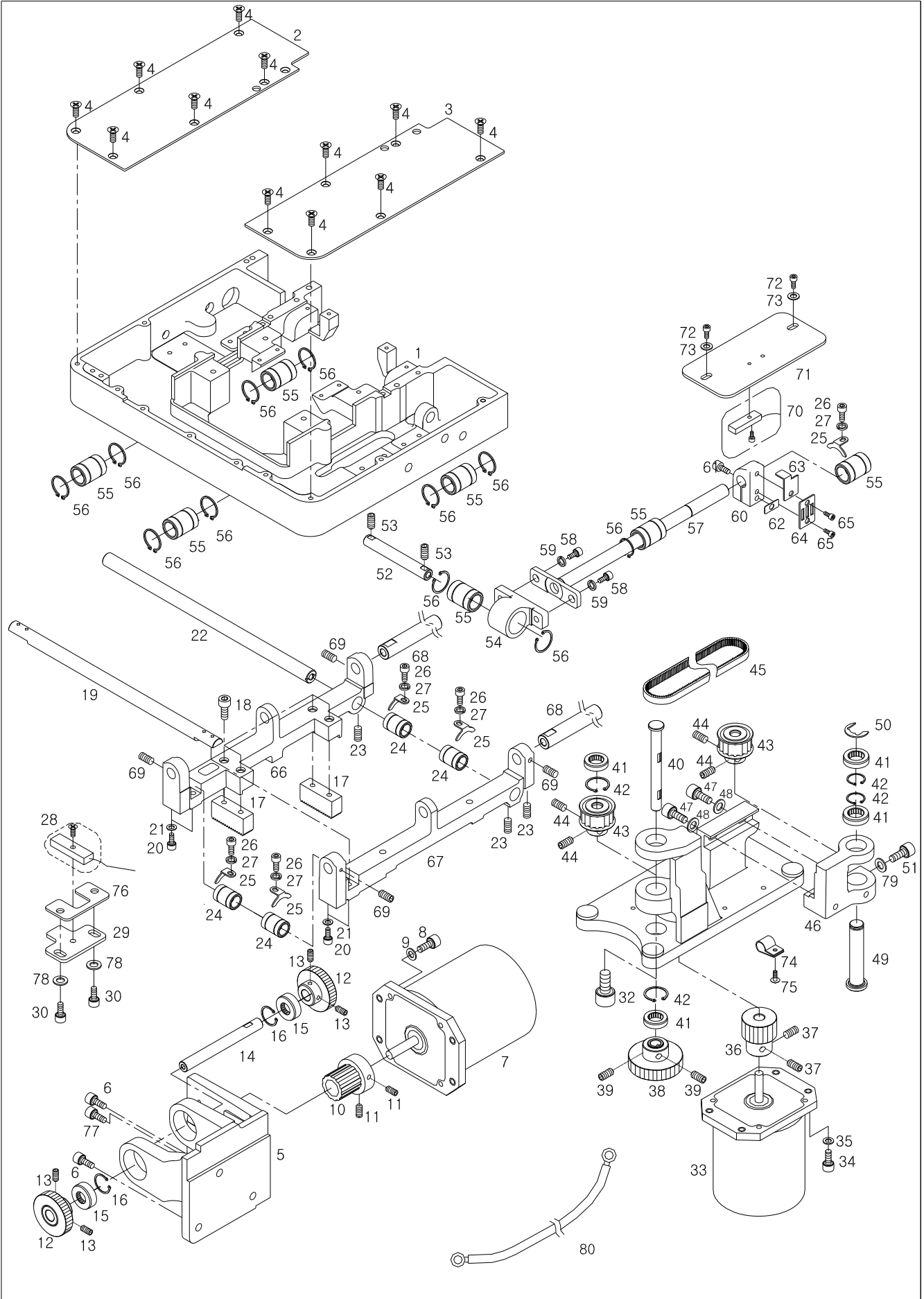



# J

## Presser Plate Mechanism

### 누름판 관계

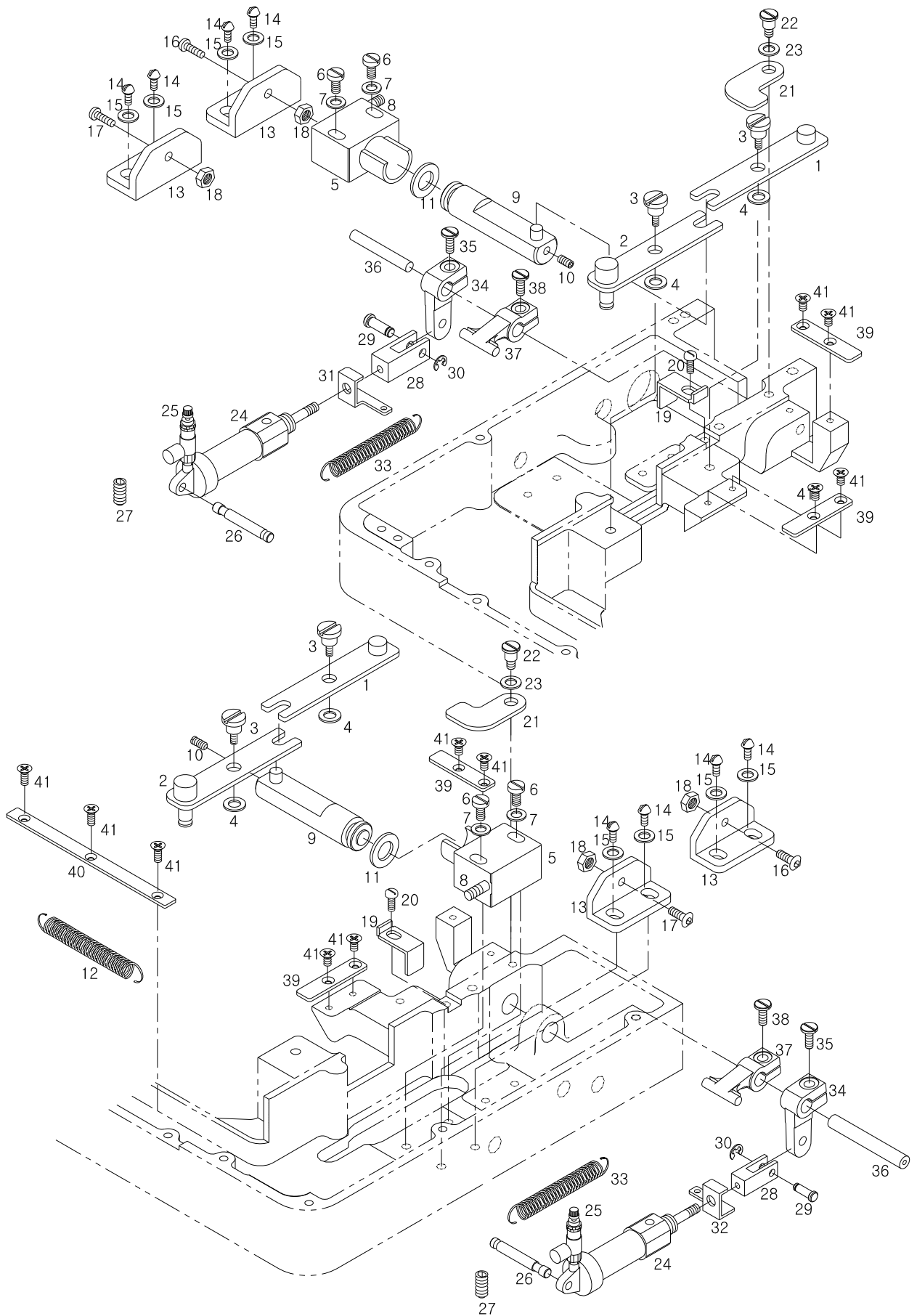



Ref. No.	Parts No.	Note	Name of Parts	품 명	Q'ty	Assembly
J-1	CPR-CA001200		Link A For Cloth Opening Ass'y	천열림 링크 A(조)	2	
J-2	CPR-CA001300		Link B For Cloth Opening Ass'y	천열림 링크 B(조)	2	
J-3	DSC-FA009200		Link Stud Screw(11/64" n=40)	링크 단나사 (11/64" n=40)	4	
J-4	DWS-AA002100		Washer	링크 단나사 와셔	4	
J-5	CPR-BD000200		Cylinder For Cloth Opening	천열림 실린더	2	
J-6	DSC-BF008600		Cylinder Fix Screw	실린더 고정나사(M5×L25×H3.5)	4	
J-7	DWS-AA000600		Washer	실린더 고정나사 와셔	4	
J-8	PPP-AA000200		Cylinder Hose Nipple	실린더 호스 너플	2	
J-9	CPR-KC000900		Cylinder Shaft Ass'y	실린더 축(조)	2	
J-10	DSC-CB000700		Pin Fixed Screw (M5)	핀 침나사(M5)	2	
J-11	DPK-AZ000400		Cylinder Shaft Rubber Packing	실린더 축 고무 패킹	2	
J-12	DSP-AB002400		Return Spring For Cloth-Opening	천열림 복귀 스프링	1	
J-13	CPR-BJ001300		Stopper Plate For Cylinder	실린더 스톱퍼	4	
J-14	DSC-BJ000200		Screw (11/64" n=40)	실린더 스톱퍼 고정나사(11/64" n=40)	8	
J-15	DWS-AA001100		Washer	고정나사 와셔	8	
J-16	PSC-AC005000		Stopper Screw A(M4×L20)	스톱퍼 나사 A(M4×L20)	2	
J-17	PSC-AC005000		Stopper Screw B(M4×L20)	스톱퍼 나사 B(M4×L20)	2	
J-18	PSN-AA002300		Nut (M4)	스톱퍼 나사 너트(M4)	4	
J-19	CPR-BJ001400		Stopper For Cover Plate	커버판 스톱퍼	2	
J-20	DSC-BJ000200		Screw (11/64" n=40)	스톱퍼 침나사(11/64" n=40)	2	
J-21	CPR-BJ001000		Cover For Presser Plate	누름판 커버	2	
J-22	DSC-FA009300		Stud Screw For Presser Plate Cover(11/64" n=40)	누름판 커버 단나사(11/64" n=40)	2	
J-23	PWS-CF000200		Band Washer	단나사 와셔(밴드와셔)	2	
J-24	PPP-CA001000		Presser Plate Air Cylinder	누름판 실린더	2	
J-25	PPP-AB000100		Air Cylinder Fitting	누름판 실린더 피팅	2	
J-26	CCP-KC000700		Cylinder Support Shaft	실린더 지지축	2	
J-27	DSC-CB000700		Screw (M5)	지지축 침나사(M5)	2	
J-28	CCP-BM000300		Clamp Cylinder Rod	클램프 실린더 로드	2	
J-29	DPN-AD004100		Pin For Cylinder Rod	실린더 로드 핀	2	
J-30	PSR-AC000300		E-Ring(φ4)	실린더 로드 핀 E-링(호칭경φ4)	2	
J-31	CCP-BB001300		Spring Hook For Presser Plate(L)	누름판 스프링걸이(좌)	1	
J-32	CCP-BB001400		Spring Hook For Presser Plate(R)	누름판 스프링걸이(우)	1	
J-33	DSP-AB001500		Return Spring For Presser Plate	누름판 복귀 스프링	2	
J-34	CCP-CM001600		Clamp Driving Lever	클램프 구동 레버	2	
J-35	DSC-BF002600		Screw (3/16" n=32)	클램프 구동 레버 침나사(3/16" n=32)	2	
J-36	CCP-KC000600		Shaft For Clamp Driving Lever	클램프 구동 레버 축	2	
J-37	CCP-CM001700		Clamp Lever B	클램프 레버 B	2	
J-38	DSC-BF007800		Screw (3/16" n=32)	클램프 레버 B 침나사(3/16" n=32)	2	
J-39	CPR-BJ001102		Guide Plate A	가이드 판 A	4	Jul.27.12
J-40	CPR-BJ001200		Guide Plate B	가이드 판 B	1	
J-41	PSC-BB000700		Guide Plate Screw(M3×L6)	가이드 판 침나사(M3×L6)	11	

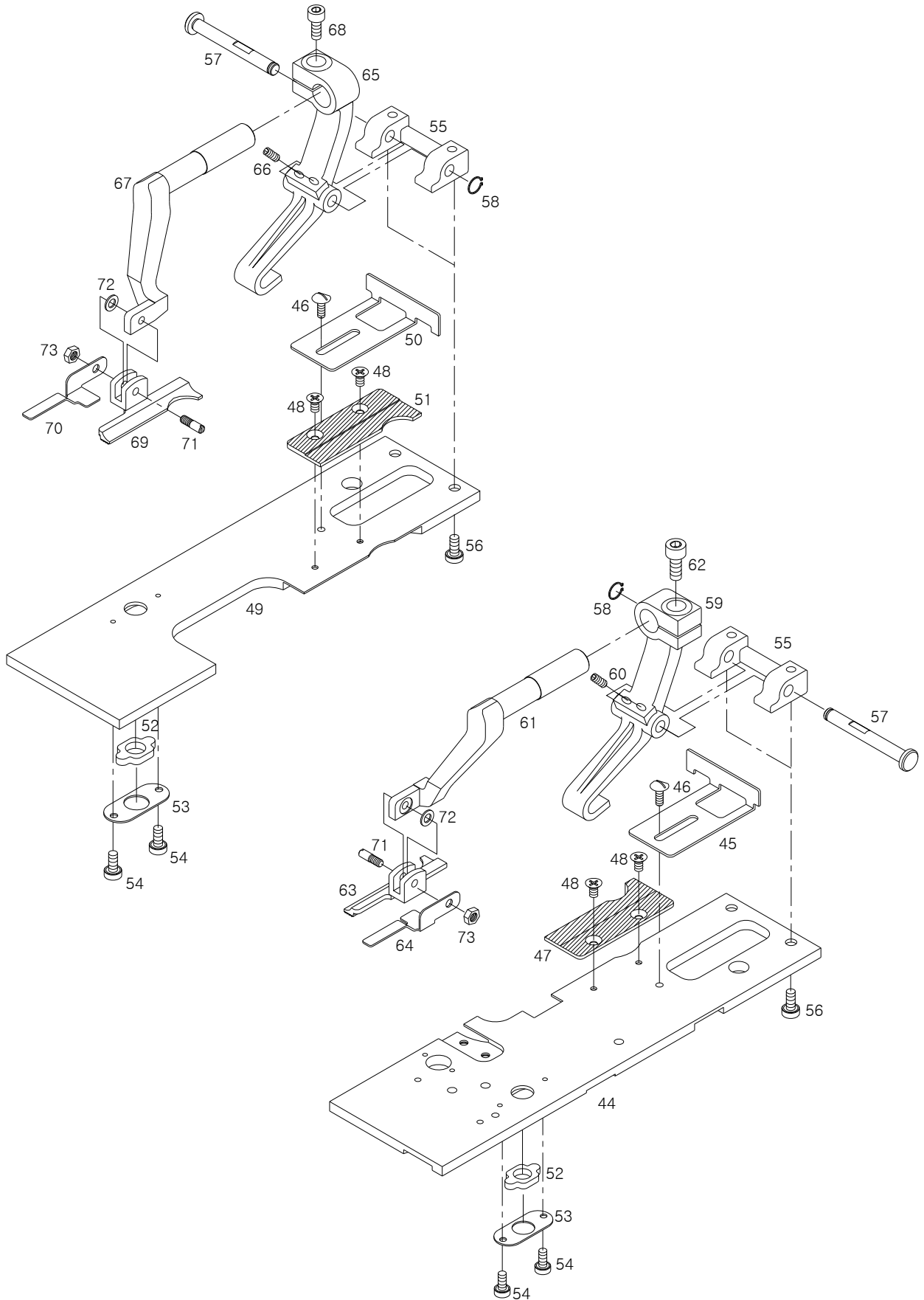

Ref. No.	Parts No.	Note	Name of Parts	품명	Q'ty	Applied
J1-44	CCP-LB000200	-01	Cover Plate(R)	커버판(우)	1	
J1-45	CCP-BJ001800	-01	Cloth Guide(R)	천 가이드(우)	1	
J1-46	DSC-BJ002500	-01	Screw For Cloth Guide(9/64" n=40)	천 가이드 집나사(9/64" n=40)	2	
J1-47	CGA-GA000400	-01	Needle Plate(R)	침판(우)	1	
J1-48	PSC-BB000700	-01	Screw For Needle Plate(M3×L6)	침판(우) 집나사(M3×L6)	4	
J1-49	CCP-LB000100	-01	Cover Plate(L)	커버판(좌)	1	
J1-50	CCP-BJ001700	-01	Cloth Guide(L)	천 가이드(좌)	1	
J1-51	CGA-GA000300	-01	Needle Plate(L)	침판(좌)	1	
J1-52	CCP-CD000601	-01	Slide Block For Cloth Opening	천열림 슬라이드 블록	2	Jan.21.11
J1-53	CCP-BJ001900	-01	Cover For Slide Block	슬라이드 블록 커버	2	
J1-54	DSC-BF001300	-01	Screw (3/32" n=56)	슬라이드 블록 커버 집나사(3/32" n=56)	4	
J1-55	CCP-BF000200	-01	Shaft Holder For Clamp Lever Shaft	클램프 레버 축 홀더	2	
J1-56	DSC-BJ000400	-01	Screw (11/64" n=40)	클램프 레버 축 홀더 집나사(11/64" n=40)	4	
J1-57	CCP-KC000800	-01	Shaft For Clamp Lever	클램프 레버 축	2	
J1-58	PSR-AG000100	-01	G-Ring (φ5)	클램프 레버 축 G-링(호칭경 φ5)	2	
J1-59	CCP-CM001900	-01	Clamp Lever(R)	클램프 레버(우)	1	
J1-60	DSC-CB000700	-01	Screw (M5)	클램프 레버(우) 집나사(M5)	2	
J1-61	CCP-BL001300	-01	Clamp Arm(R)	클램프 암(우)	1	
J1-62	PSC-AC000900	-01	Screw (M5×L15)	클램프 암 집나사(M5×L15)	1	
J1-63	CGA-BL000200	-01	Clamp (R)	클램프(우)	1	
J1-64	CCP-BJ002100	-01	Work Clamp Plate(R)	클램프 판(우)	1	
J1-65	CCP-CM001800	-01	Clamp Lever(L)	클램프 레버(좌)	1	
J1-66	DSC-CB000700	-01	Screw (M5)	클램프 레버(좌) 집나사(M5)	2	
J1-67	CCP-BL001200	-01	Clamp Arm(L)	클램프 암(좌)	1	
J1-68	PSC-AC000900	-01	Screw (M5×L15)	클램프 암 집나사(M5×L15)	1	
J1-69	CGA-BL000100	-01	Clamp (L)	클램프(좌)	1	
J1-70	CCP-BJ002000	-01	Work clamp Plate(L)	클램프 판(좌)	1	
J1-71	DSC-FF000700	-01	Pin For Work Clamp Support (M3)	클램프 지지 핀(M3)	2	
J1-72	PWS-CF000100	-01	Band Washer	클램프 지지 핀 와셔(밴드와셔)	2	
J1-73	PSN-AA001900	-01	Nut (M3)	클램프 지지 핀 너트(M3)	2	

NOTE: 01 → Long Trimmer(긴 사절형)  
02 → Short Trimmer(짧은 사절형)

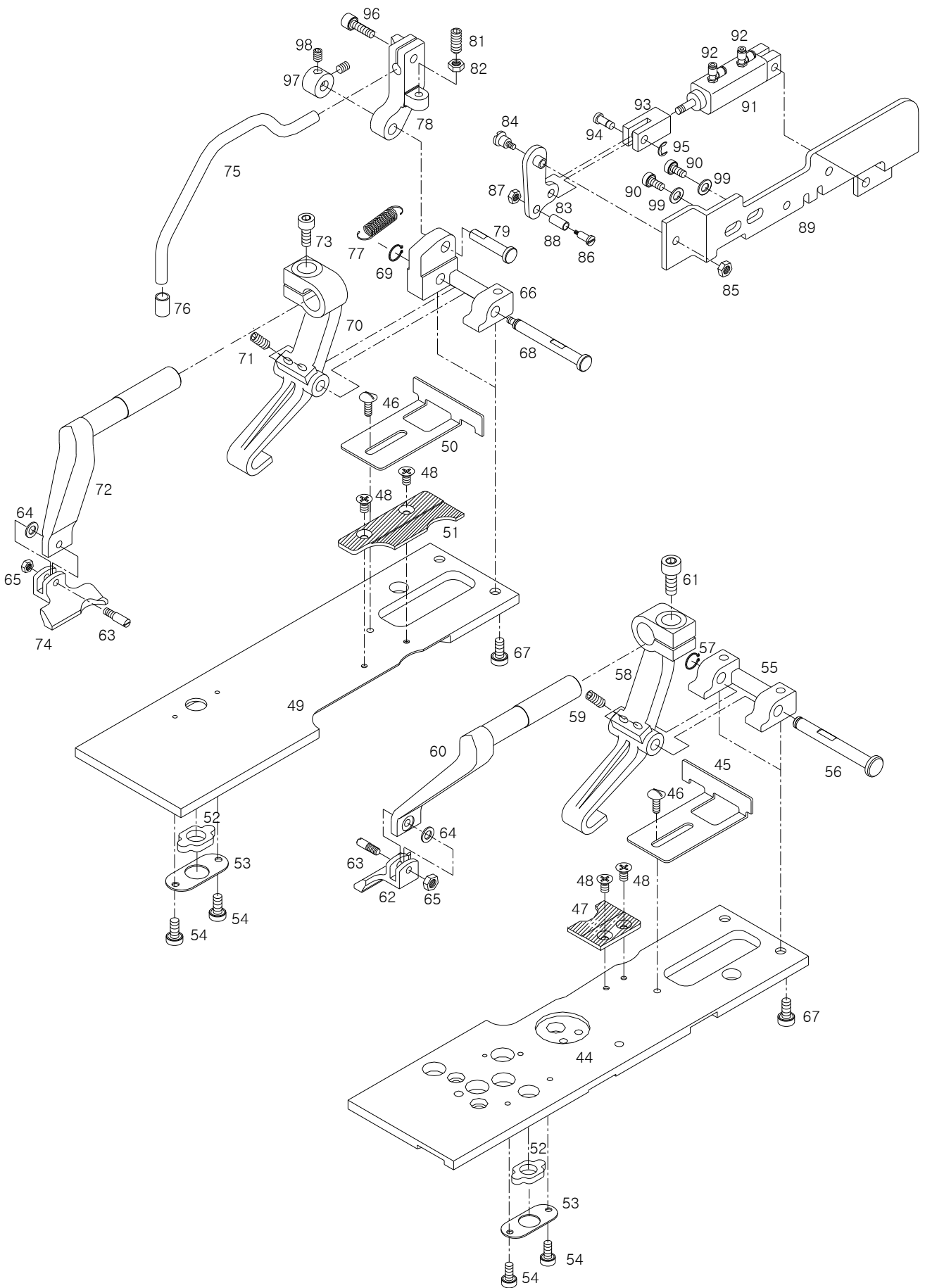





Ref. No.	Parts No.	Note	Name of Parts	품 명	Q'ty	Applied
J2-44	GP-001700-00	-02	Cover Plate(R)	커버판(우)	1	
J2-45	CCP-BJ001800	-02	Cloth Guide(R)	천 가이드(우)	1	
J2-46	DSC-BJ002500	-02	Screw For Cloth Guide(9/64" n=40)	천 가이드 첩나사(9/64" n=40)	2	
J2-47	GP-001689-02	-02	Needle Plate L3(R)	침판L3(우)	1	
J2-48	PSC-BB000700	-02	Screw(M3×L6)	침판(우) 첩나사(M3×L6)	4	
J2-49	GP-001699-00	-02	Cover Plate(L)	커버판(좌)	1	
J2-50	CCP-BJ001700	-02	Cloth Guide (R)	천 가이드(좌)	1	
J2-51	GP-001690-03	-02	Needle Plate L3(L)	침판L3(좌)	1	
J2-52	CCP-CD000601	-02	Slide Block For Cloth Opening	천열림 슬라이드 블록	2	Jan.21.11
J2-53	CCP-BJ001900	-02	Cover For Slide Block	슬라이드 블록 커버	2	
J2-54	DSC-BF001300	-02	Screw (3/32" n=56)	슬라이드 블록 커버 첩나사(3/32" n=56)	4	
J2-55	CCP-BF000200	-02	Shaft Holder For Clamp Lever Shaft(R)	클램프 레버 축 홀더(우)	1	
J2-56	CCP-KC000800	-02	Shaft For Clamp Lever(R)	클램프 레버 축(우)	1	
J2-57	PSR-AG000100	-02	G-Ring (φ5)	클램프 레버 축 G-링(호칭경 φ5)	1	
J2-58	CCP-CM001900	-02	Clamp Lever(R)	클램프 레버(우)	1	
J2-59	DSC-CB000700	-02	Screw (M5)	클램프 레버(우) 첩나사(M5)	2	
J2-60	GP-001691-00	-02	Clamp Arm(R)	클램프 암(우)	1	
J2-61	PSC-AC000900	-02	Screw(M5×L15)	클램프 암 첩나사(M5×L15)	1	
J2-62	GP-001695-00	-02	Clamp L3(R)	클램프 L3(우)	1	
J2-63	DSC-FF000700	-02	Pin For Work Clamp Support(M3)	클램프 지지 핀(M3)	2	
J2-64	PWS-CF000100	-02	Band Washer	클램프 지지 핀 와셔(밴드와셔)	2	
J2-65	PSN-AA001900	-02	Nut (M3)	클램프 지지 핀 너트(M3)	2	
J2-66	GP-001688-01	-02	Shaft Holder For Clamp Lever(L)	클램프 레버 축 홀더(좌)	1	
J2-67	DSC-BJ000400	-02	Screw(11/64" n=40)	클램프 레버 축 홀더 첩나사(11/64" n=40)	4	
J2-68	GP-001685-00	-02	Shaft For Clamp Lever(L)	클램프 레버 축(좌)	1	
J2-69	PSR-AG000100	-02	G-Ring (φ5)	클램프 레버 축 G-링(호칭경 φ5)	1	
J2-70	CCP-CM001800	-02	Clamp Lever(L)	클램프 레버(좌)	1	
J2-71	DSC-CB000700	-02	Screw (M5)	클램프 레버(좌) 첩나사(M5)	2	
J2-72	GP-001692-00	-02	Clamp Arm(L)	클램프 암(좌)	1	
J2-73	PSC-AC000900	-02	Screw(M5×L15)	클램프 암 첩나사(M5×L15)	1	
J2-74	GP-001694-00	-02	Clamp L3(L)	클램프 L3(좌)	1	
J2-75	GP-001693-00	-02	Arm For Sub Clamp	보조 클램프 암	1	
J2-76	GP-001687-00	-02	Rubber Cap For Sub Clamp Arm	보조 클램프 암 고무 마개	1	
J2-77	GP-001684-01	-02	Sub Clamp Arm Retrtn Spring	보조 클램프 암 복귀 스프링	1	
J2-78	GP-001696-01	-02	Holder For Sub Clamp Arm	보조 클램프 암 홀더	1	
J2-79	GP-001686-01	-02	Sub Clamp Arm Holder Shaft	보조 클램프 암 홀더 축	1	
J2-81	SC-000165-00	-02	Stopper Screw(1/8" n=40)	스토퍼 나사(1/8" n=40)	1	
J2-82	DSN-AA001700	-02	Nut(1/8" n=40)	스토퍼 나사 너트(1/8" n=40)	1	
J2-83	GP-001697-00	-02	Clamp Link Ass'y	클램프 링크(조)	1	
J2-84	DSC-FA007800	-02	Fix Stud screw(11/64" n=40)	클램프 링크 고정 단나사(11/64" n=40)	1	
J2-85	DSN-AA000900	-02	Nut(11/64" n=40)	단나사 너트(11/64" n=40)	1	
J2-86	GP-001753-00	-02	Stud Screw For Roller(M4)	롤러 단나사(M4)	1	
J2-87	PSN-AA001500	-02	Nut	롤러 단나사 너트(M4)	1	
J2-88	GP-001752-00	-02	Clamp Link Roller	클램프 링크 로울러	1	
J2-89	GP-001698-00	-02	Cylinder Support Ass'y	실린더 지지대(조)	1	
J2-90	DSC-BF001000	-02	Screw (11/64" n=40)	실린더 지지대 고정나사(11/64" n=40)	2	
J2-91	GP-002147-00	-02	Sub Clamp Air Cylinder	보조 클램프 Air Cylinder	1	
J2-92	PPP-AA000100	-02	Air Cylinder Fitting	Air Cylinder Fitting	2	
J2-93	CUT-BM000100	-02	Sub Clamp Cylinder Knuckle	보조 클램프 실린더 너클	1	
J2-94	DPN-AD004100	-02	Cylinder Knuckle Pin	실린더 너클 핀	1	
J2-95	PSR-AC000300	-02	E-Ring(φ4)	실린더 너클 핀 E-링(호칭경φ4)	1	
J2-96	PSC-AC007100	-02	Screw(M4×L10)	보조클램프 암 고정나사(M4×L10)	1	
J2-97	CL-000118-00	-02	Collar	홀더 축 카라	1	
J2-98	PSC-CB000200	-02	Screw(M4×L4)	카라 첩나사(M4×L4)	2	
J2-99	PWS-AA000400	-02	Washer	평와셔	2	

NOTE: 01 → Long Trimmer(긴 사절형)  
02 → Short Trimmer(짧은 사절형)

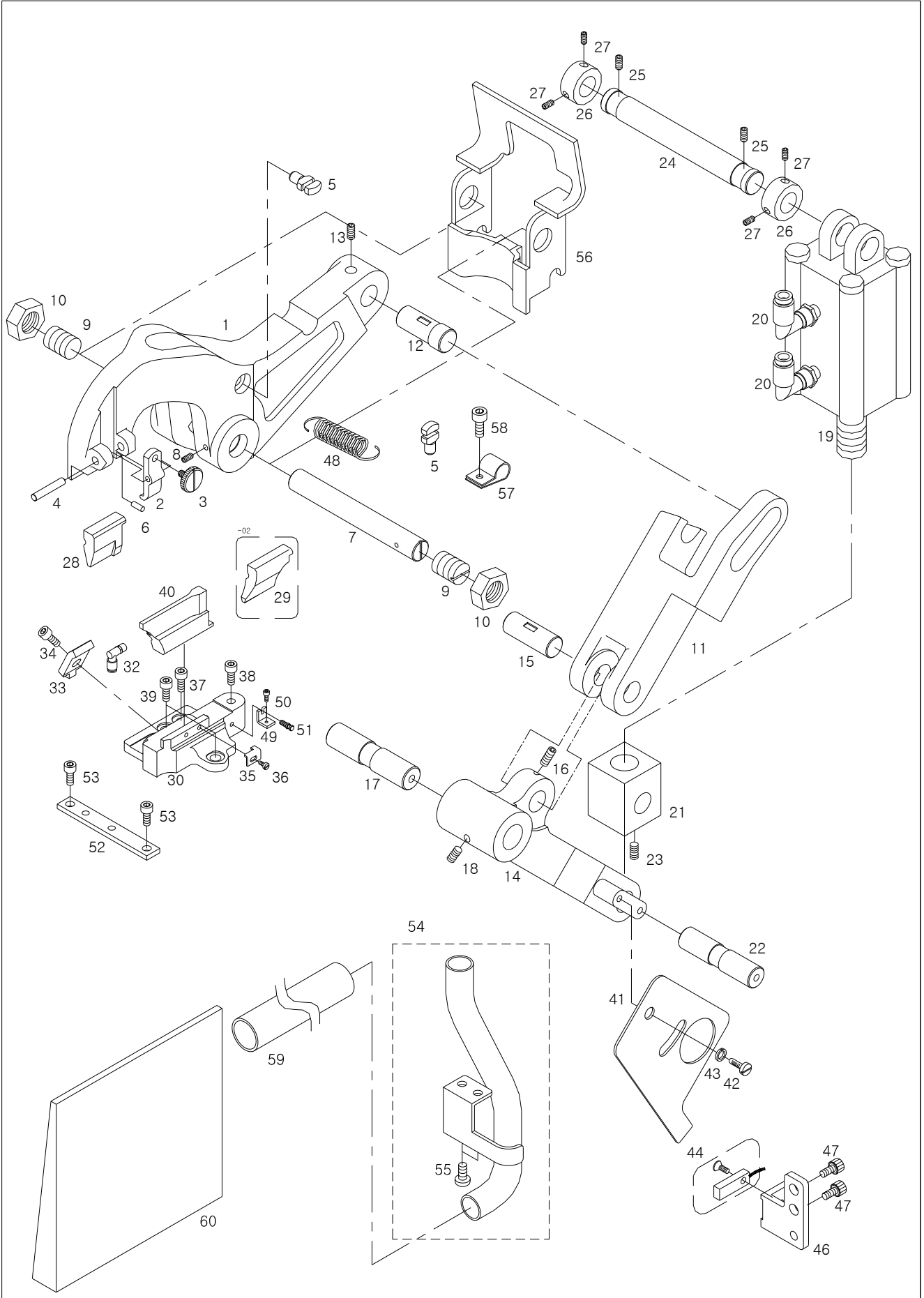



Ref. No.	Parts No.	Note	Name of Parts	품 명	Q'ty	Applied
K-1	CCT-CM000100		Cutter Lever	커터 레버	1	
K-2	CCT-BL000100		Hammer Presser	해머 누름판	1	
K-3	DSC-BF007600		Set Screw For Hammer Presser Plate	해머 누름판 고정나사(M5)	1	
K-4	PBR-BF000100		Needle Roller(φ4×L25)	해머 누름판 고정 니들 롤러(φ4×L25)	1	
K-5	DSC-HD000500		Spring Hook	스프링 걸이	2	Feb.13.09
K-6	PBR-BF000200		Needle Roller(φ3×L11.8)	해머 고정 니들 롤러(φ3×L11.8)	1	
K-7	CCT-KC000100		Cutter Lever Shaft	커터 레버 축	1	
K-8	DSC-CB000500		Screw(15/64" n=28)	커터 레버 축 짐나사(15/64" n=28)	1	
K-9	DSC-CA001800		Support Screw(M14×P1.5)	지지나사(M14×P1.5)	2	
K-10	PSN-AA001600		Nut(M14×P1.5)	지지나사 너트(M14×P1.5)	2	
K-11	CCT-CA000100		Link A	링크 A	1	
K-12	CCT-KF000100		Link Shaft C	링크 축 C	1	
K-13	DSC-CB000500		Screw(15/64" n=28)	링크 축 C 짐나사(15/64" n=28)	1	
K-14	CCT-CA000200		Link C	링크 C	1	
K-15	CCT-KC000400		Link Shaft B	링크 축 B	1	
K-16	DSC-CB000500		Screw(15/64" n=28)	링크 축 B 짐나사(15/64" n=28)	1	
K-17	CCT-KC000500		Link Shaft A	링크 축 A	1	
K-18	DSC-CB000500		Screw(15/64" n=28)	링크 축 A 짐나사(15/64" n=28)	1	
K-19	PPP-CA000800		Cutter Air Cylinder	커터 Air Cylinder	1	
K-20	PPP-AA001500		Cutter Air Cylinder Fitting	커터 Air Cylinder Fitting	2	
K-21	CCT-BM000101		Cutter Cylinder Rod	커터 실린더 로드	1	Apr.01.10
K-22	CCT-KC000300		Cylinder Rod Shaft	실린더 로드 축	1	
K-23	DSC-CB000500		Screw(15/64" n=28)	실린더 로드 축 짐나사(15/64" n=28)	1	
K-24	CCT-KC000200		Cutter Cylinder Support Shaft	커터 실린더 지지 축	1	
K-25	DSC-CB000500		Screw(15/64" n=28)	실린더 지지 축 짐나사(15/64" n=28)	2	
K-26	DCL-AA002700		Cutter Shaft Collar	커터 축 카라	2	
K-27	DSC-CB000500		Screw(15/64" n=28)	커터 축 카라 짐나사(15/64" n=28)	4	
K-28	CGA-GN000100	-01	Hammer-26mm	해머-26mm	1	
K-29	GP-001701-01	-02	Hammer-S20mm	해머-S20mm	1	
K-30	CCT-BB000300		Cutter Bracket	커터 브라켓	1	
K-32	PPP-AA000100		Cutter Bracket Air Fitting	커터 브라켓 Air Fitting	1	
K-33	CCT-BF000201		Cutter Holder	커터 잡이	1	
K-34	PSC-AC001700		Screw(M5×L10)	커터 잡이 짐나사(M5×L10)	1	
K-35	CCT-BJ000500		Cutter Stopper Plate	커터 스토퍼 판	1	
K-36	DSC-AC000500		Screw(M3×L3.8)	스토퍼 판 짐나사(M3×L3.8)	1	
K-37	PSC-AC007100		Cutter Bracket Screw A(M4×L10)	커터 브라켓 짐나사A(M4×L10)	1	
K-38	PSC-AC007200		Cutter Bracket Screw B(M6×L25)	커터 브라켓 짐나사B(M6×L25)	1	
K-39	PSC-AC001700		Cutter Bracket Screw C(M5×L10)	커터 브라켓 짐나사C(M5×L10)	2	
K-40	CGA-GF000100		Cutter-38mm	커터-38mm	1	
K-41	CCT-BJ000300		Cutter Sensor Plate	커터 센서 판	1	
K-42	DSC-BJ000200		Screw(11/64" n=40)	센서 판 짐나사(11/64" n=40)	2	
K-43	DWS-CA000100		Spring Washer	센서 판 스프링 와셔	2	
K-44	CA-000723-00		Cutter Sensor(Ass'y)	커터 센서(조)	1	
K-46	CCT-BB000400		Cutter Sensor Bracket	커터 센서 브라켓	1	
K-47	PSC-BA000700		Screw(M4×L8)	브라켓 짐나사(M4×L8)	2	
K-48	DSP-AB001300		Return Spring For Cutter Lever	커터 레버 복귀 스프링	1	
K-49	CCT-BJ000600		Cutter Adjusting Plate	커터 조정판	1	
K-50	PSC-AC007100		Screw(M4×L10)	커터 조정판 짐나사(M4×L10)	1	
K-51	DSC-HZ000200		Cutter Adjusting Screw	커터 조정 나사(M4)	1	
K-52	CCT-BJ000400		Cutter Bracket Guide	커터 브라켓 가이드	1	
K-53	PSC-AC007100		Screw(M4×L10)	커터 브라켓 가이드 짐나사(M4×L10)	2	
K-54	ACT-PS000100		Cutter Pipe(Ass'y)	커터 파이프(조)	1	
K-55	DSC-BJ000200		Screw(11/64" n=40)	커터 파이프 짐나사(11/64" n=40)	2	
K-56	CCT-FZ000100		Cutter Lever Cover	커터 레버 커버	1	
K-57	PTC-AH000500		Code Holder(3N)	코드 홀더(3N)	1	
K-58	PSC-AC007100		Screw(M4×L10)	짐나사(M4×L10)	1	
K-59	GP-023880-00		Hose A	재봉 잔유물 배출 호스	1.5	

NOTE: 01 → Long Trimmer(긴 사절형)  
02 → Short Trimmer(짧은 사절형)

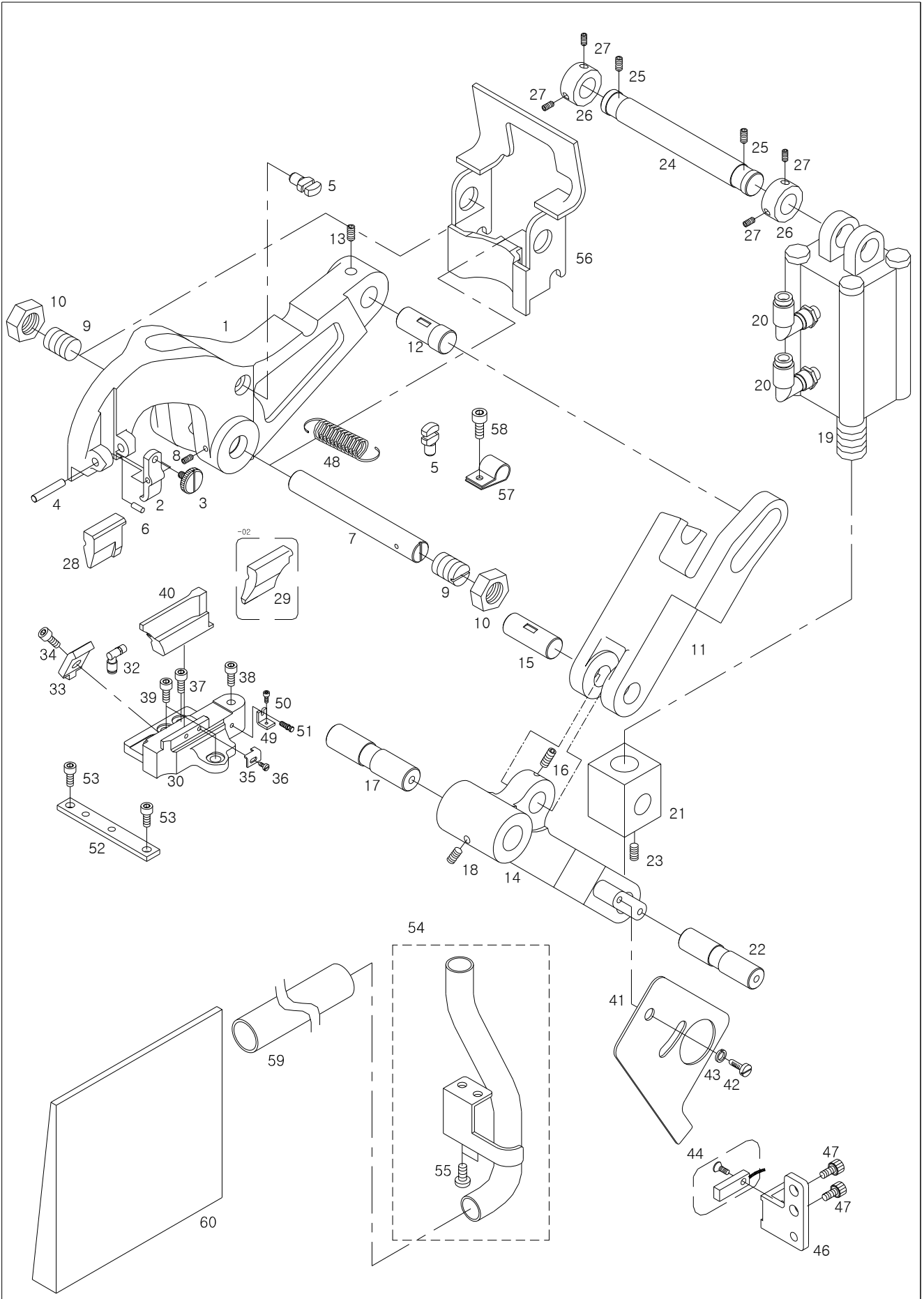





# Double Chain Stitch Looper Mechanism

## 이중환봉 관계

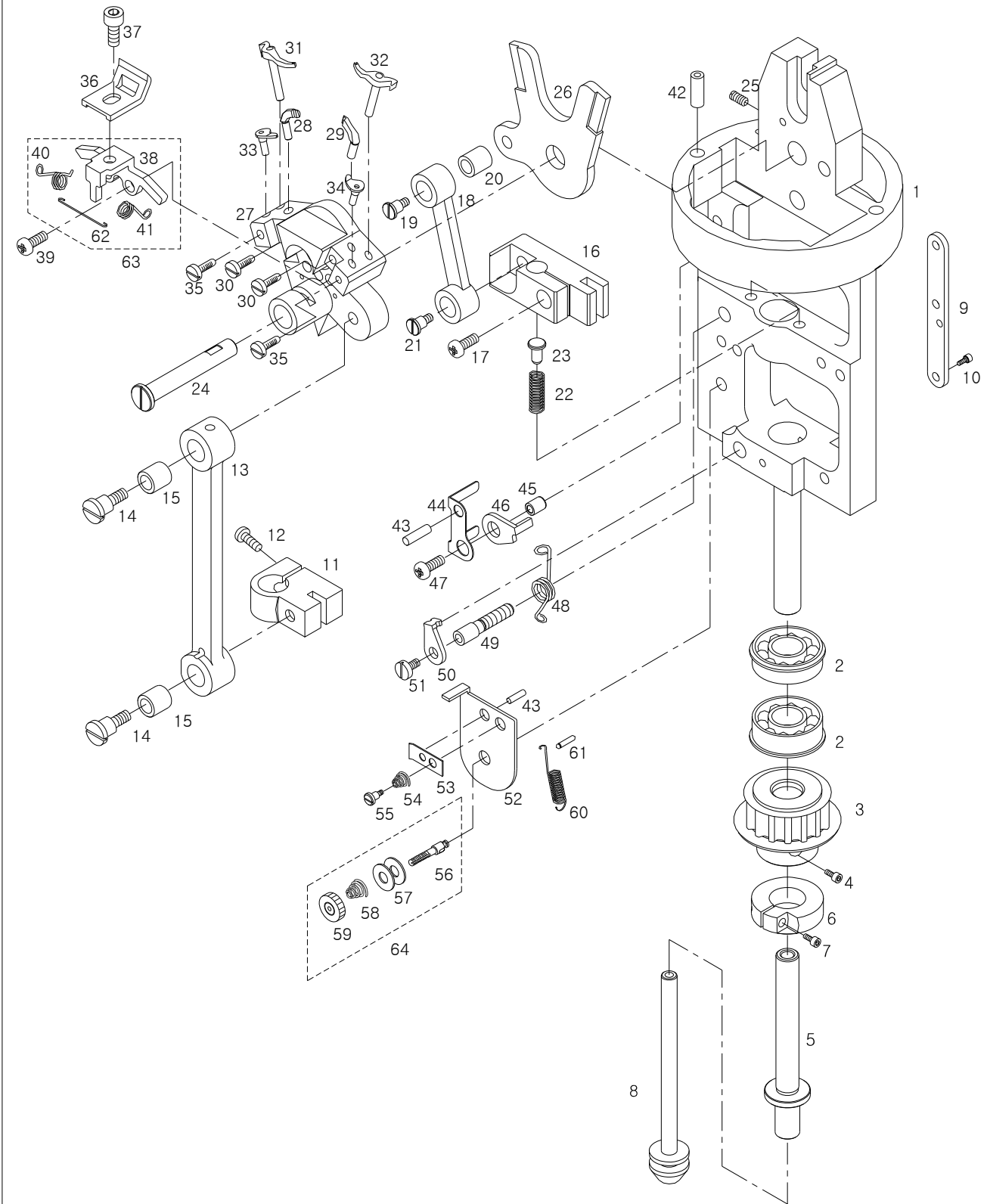



Ref. No.	Parts No.	Note	Name of Parts	품 명	Q'ty	Assembly
L-1	CLP-BA000200		Looper Base	루퍼 베이스	1	
L-2	PBR-AA002200		Bearing	루퍼 베이스 베어링(6003ZZNR)	2	
L-3	DPL-BC000901		Looper Base Rotation Pulley	루퍼 베이스 회동 폴리	1	
L-4	DSC-BA001800		Screw(9/64" n=40)	루퍼 베이스 회동 폴리 고정나사(9/64" n=40)	1	
L-5	CLP-KF000100		Looper Driving Shaft	루퍼 구동축	1	
L-6	DCL-AC000100		Clamp For Looper Driving Shaft	루퍼 구동축 블록 클램프	1	
L-7	PSC-AC007300		Screw(M3×L12)	루퍼 구동축 블록 클램프 고정나사(M3×L12)	1	
L-8	CLP-KZ000100		Spreader Link Shaft Ass'y	스프레더 링크 축(조)	1	
L-9	CLP-BJ000100		LS-Slide Guide	LS-슬라이드 가이드	1	
L-10	PSC-BA000400		Screw(M3×L6)	LS-슬라이드 가이드 고정나사(M3×L6)	3	
L-11	CLP-BF000100		Clamp For Looper Link	루퍼 링크 클램프	1	
L-12	PSC-BA000800		Screw(M5×L12)	루퍼 링크 클램프 고정나사(M5×L12)	1	
L-13	CLP-CA000200		Drive Link For Looper	루퍼 구동 링크	1	
L-14	DSC-FA008400		Stud Screw For Looper Link	루퍼 링크 단나사	2	
L-15	CLP-CL000200		Roller For Looper Link Stud	루퍼 링크 단나사 롤러	2	
L-16	CLP-BA000100		Base For Spreader Link	스프레더 링크 베이스	1	
L-17	PSC-BA000800		Screw(M5×L12)	스프레더 링크 베이스 고정나사(M5×L12)	1	
L-18	CLP-CA000100		Link For Spreader Cam	스프레더 캠 링크	1	
L-19	DSC-FA008200		Stud Screw For Spreader Cam Link(A)	스프레더 캠 링크 단나사(A)	1	
L-20	CLP-CL000100		Roller Screw For Spreader Cam Link	스프레더 캠 링크 롤러	1	
L-21	DSC-FA008300		Stud Screw For Spreader Cam Link(B)	스프레더 캠 링크 단나사(B)	1	
L-22	GP-001163-00		Spreader Compression Spring	스프레더 압축 스프링	2	
L-23	DPN-AD004700		Guide For Spreader Compression Spring	스프레더 압축 스프링 가이드	2	
L-24	CLP-KC000200		Holder Support Shaft	홀더 지지 축	1	
L-25	PSC-CB000100		Screw(M6×L6)	홀더 지지 축 고정나사(M6×L6)	1	
L-26	CLP-DZ000100		Spreader Driving Cam	스프레더 구동 캠	1	
L-27	CLP-BB000100		Ls Holder Bracket	LS 홀더 브라켓	1	
L-28	GP-001225-00		Looper(L)	루퍼(좌)	1	
L-29	GP-001224-00		Looper(R)	루퍼(우)	1	
L-30	DSC-BF008200		Screw(M2.6×P0.45)	루퍼 고정나사(M2.6×P0.45)	2	
L-31	GP-001223-00		Spreader(L)	스프레더(좌)	1	
L-32	GP-001222-00		Spreader(R)	스프레더(우)	1	
L-33	CLP-CM000400		Spreader Stopper(L)	스프레더 스톱퍼(좌)	1	
L-34	CLP-CM000500		Spreader Stopper(R)	스프레더 스톱퍼(우)	1	
L-35	DSC-BF008200		Screw(M2.6×P0.45)	스프레더 스톱퍼 고정나사(M2.6×P0.45)	2	
L-36	CLP-HG000100		Needle Guide	바늘 가이드	1	
L-37	DSC-AC000500		Screw(M3×L6)	바늘 가이드 고정나사(M3×L6)	1	
L-38	CLP-BB000200		Needle Guide Support	바늘 가이드 지지대	1	L-63
L-39	PSC-BA000500		Screw(M3×L6)	바늘 가이드 지지대 고정나사(M3×L6)	2	
L-40	DSP-AC002700		Needle Guide Support Spring(L)	바늘 가이드 지지대 스프링(좌)	1	L-63
L-41	DSP-AC002800		Needle Guide Support Spring(R)	바늘 가이드 지지대 스프링(우)	1	
L-42	CMB-BQ000100		Looper Thread Guide Pipe	밀실 안내 파이프	1	
L-43	DPN-AA004800		Guide Pin	안내핀	2	
L-44	CLP-BJ000700		Plate For Thread Support	실지판	1	
L-45	CLP-CL000500		Collar For Thread Support Plate	실지판 부착 카라	1	
L-46	CLP-BJ000600		Spring Guide For Lower Thread	밀실 지지 스프링 가이드	1	
L-47	PSC-BA000900		Screw(M4×L14)	밀실지지 스프링 가이드 고정나사(M4×L14)	1	
L-48	DSP-BB000300		Thread Take-Up Spring	실채기 스프링	1	
L-49	CLP-HM000100		Shaft For Spring Guide	스프링 가이드 축	1	
L-50	CLP-BJ000500		Plate For Lower Thread Support Spring	밀실지지 스프링 판	1	
L-51	PSC-BA000400		Screw(M3×L5)	밀실지지 스프링 판 고정나사(M3×L5)	1	
L-52	CLP-BJ000300		Support Plate For Lower Thread	밀실 지지판	1	
L-53	CLP-BJ000400		Presser Plate For Lower Thread	밀실 누름판	1	
L-54	DSP-BA000800		Thread Tension Spring	실장력 조절 스프링	1	
L-55	DSC-FD000700		Stud Screw For Thread Tension Spring	실장력 조절 스프링 단나사	1	
L-56	CTA-HM000901		Lower Thread Tension Shaft	밀실 조절 장치 축	1	L-64
L-57	CTA-HM000600		Lower Thread Tension Disk	밀실 조절 장치 접시	2	



# Double Chain Stitch Looper Mechanism

## 이중환봉 관계

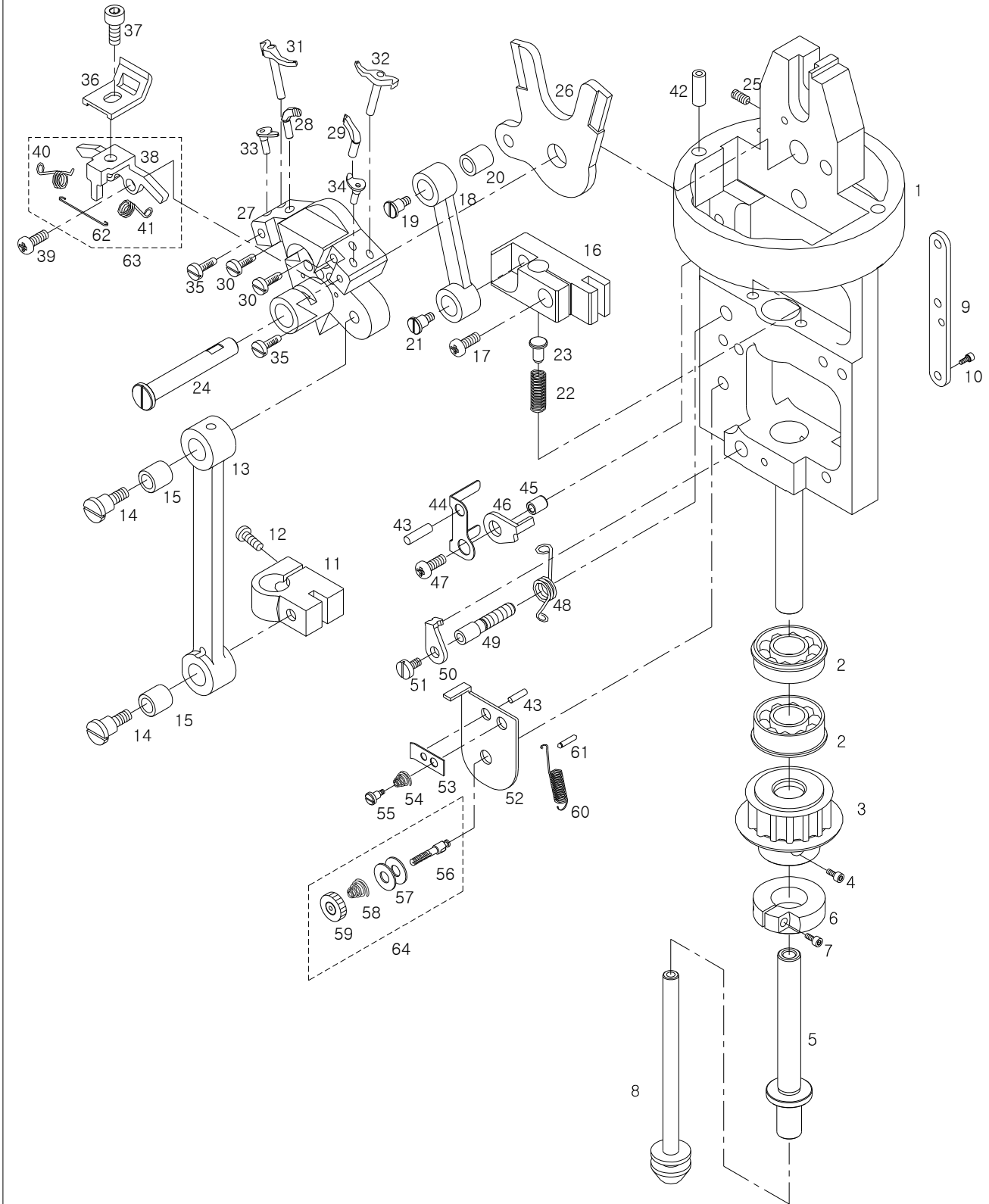





# L1

## Double Chain Stitch Looper Mechanism (01)

### 이중환봉 관계 (01)

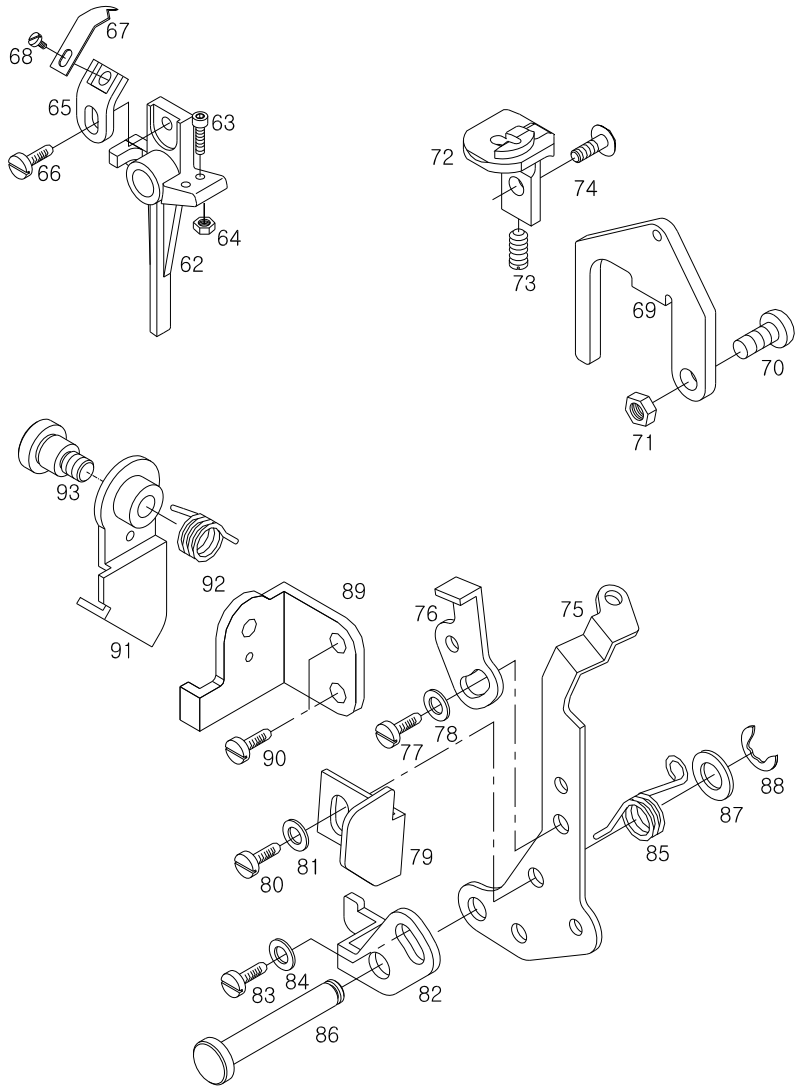



# L2

## Double Chain Stitch Looper Mechanism (02)

### 이중환봉 관계 (02)

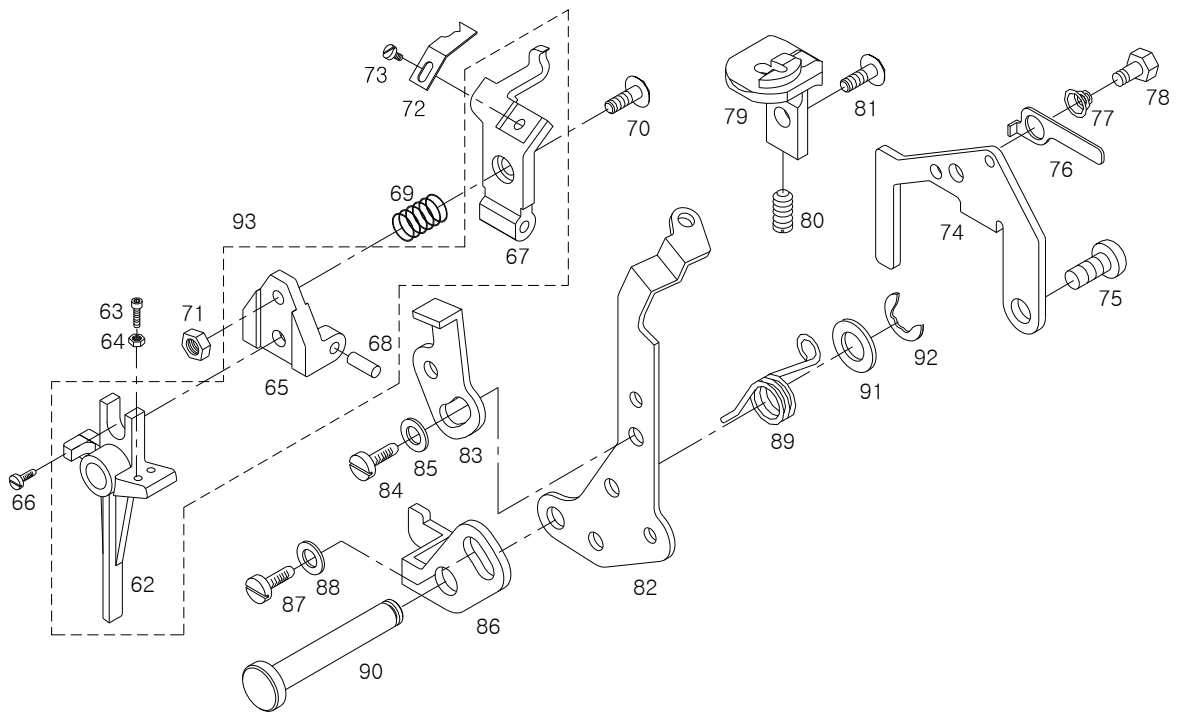



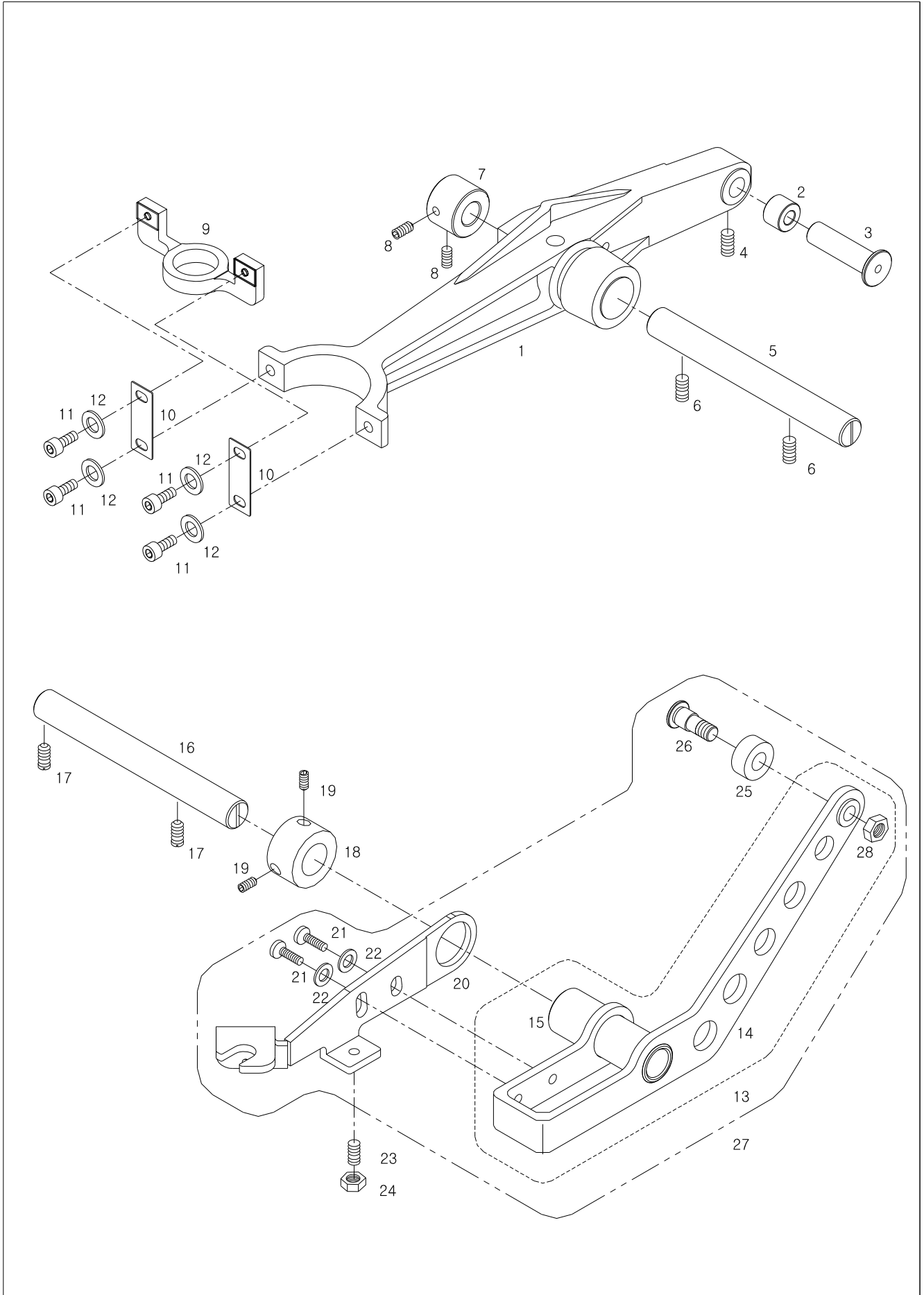



# N

## Thread Release & Thread Tension Mechanism

### 실조절 장치 관계

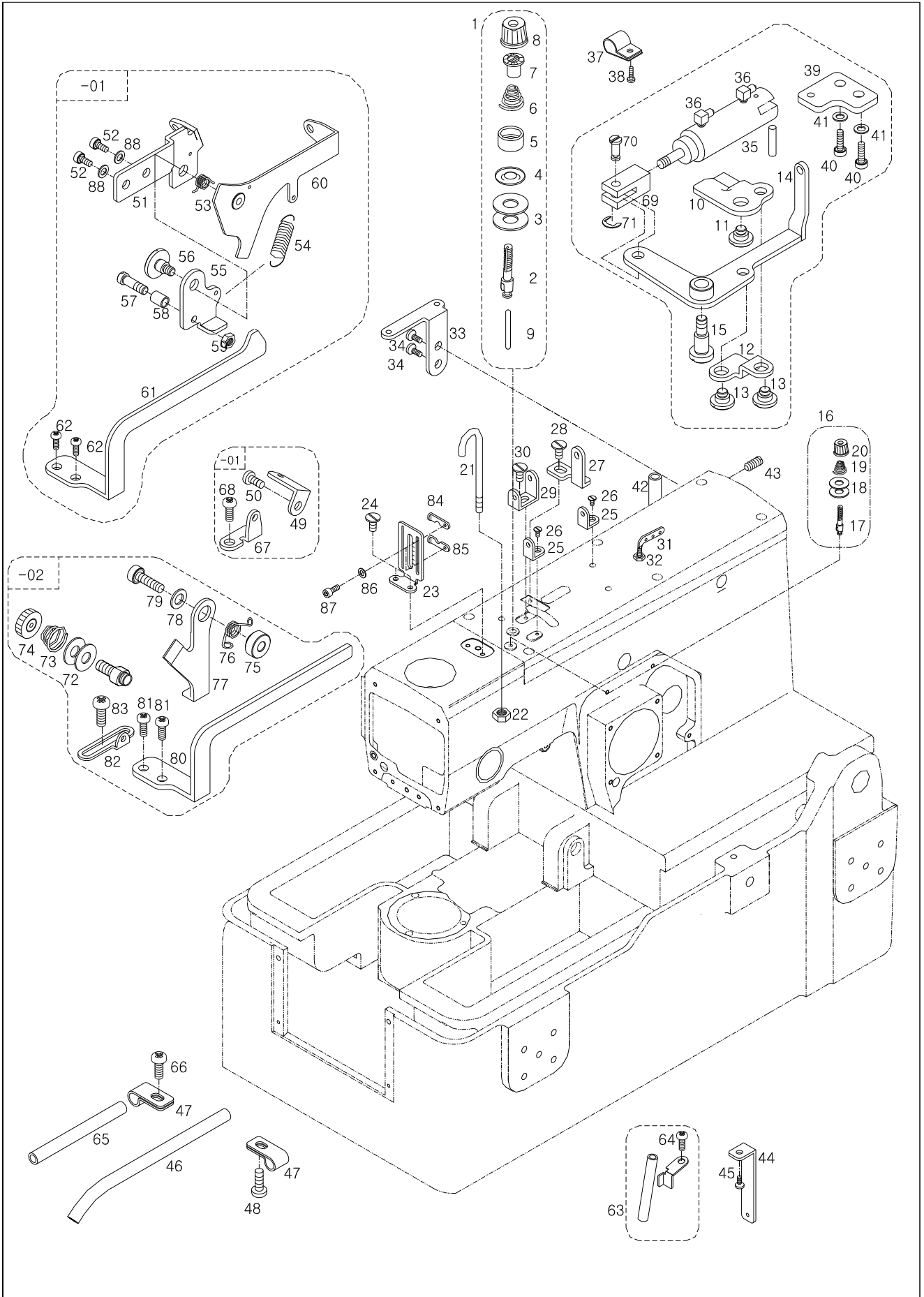



Ref. No.	Parts No.	Note	Name of Parts	품 명	Q'ty	Assembly
N-1	ATA-PS001401		Thread Tension Adjusting Ass'y	주 실조절 장치(조)	1Set	N-1
N-2	40-224A-300G		Thread Tension Adjusting Shaft	실조절 장치 축	1	
N-3	CTA-HL000400		Thread Guide Disk	실안내 접시	2	
N-4	CTA-BJ000200		Thread Guide Disk Presser Plate	실안내 접시 누름판	1	
N-5	CTA-BD000300		Spring Cover	스프링 커버	1	
N-6	DSP-BA001200		Thread Tension Adjusting Spring	실장력 조절 스프링	1	
N-7	CTA-BN000200		Spring Stopper	실장력 조절 스프링 스톱퍼	1	
N-8	DSN-CD000100		Nut	실조절 장치 너트	1	
N-9	DPN-AA004600		Upper Thread Tension Release Pin	윗실 조절 장력핀	1	
N-10	CTR-CA000500		Thread Release Driving Plate	실늦추기 작동판	1	
N-11	DSC-FA004300		Stud Screw Thread Release	실늦추기 단나사	1	
N-12	CTR-CA000600		Link For Thread Release Driving Plate	실늦추기 작동판 연결링크	1	
N-13	DSC-FA007700		Stud For Thread Release Driving Plate Link	실늦추기 작동판 연결링크 단나사	2	
N-14	CTR-CM000100		Upper Thread Adjusting Lever(Ass'y)	윗실 조절 레버 (조)	1	N-16
N-15	DSC-FA007800		Stud For Upper Thread Adjusting Lever	윗실 조절 레버 단나사	1	
N-16	ATA-PS001500		Sub Thread Tension Adjusting Ass'y	보조 실조절 장치 (조)	1Set	
N-17	CTA-HM000700		Sub Thread Tension Adjusting Shaft	보조 실조절 장치 축	1	
N-18	CTA-HL000500		Sub Thread Guide Disk	보조 실안내 접시	2	
N-19	DSP-BA001100		Sub Thread Tension Adjusting Spring	보조 실장력 조절 스프링	1	
N-20	DSN-CD000400		Nut	보조 실조절 장치 너트	1	
N-21	CMB-HK003300		Pin For Upper Thread Guide	윗실 가이드핀	1	
N-22	DSN-AA001000		Nut(9/64" n=40)	윗실 가이드핀 너트 (9/64" n=40)	1	
N-23	CMB-HK003400		Upper Thread Guide A	윗실 가이드 A	1	
N-24	DSC-BF001000		Screw(11/64" n=40)	윗실 가이드 A 고정나사 (11/64" n=40)	2	
N-25	CMB-HK002600		Upper Thread Guide B	윗실 가이드 B	2	
N-26	DSC-BA000900		Screw(9/64" n=40)	윗실 가이드 B 고정나사 (9/64" n=40)	2	
N-27	CMB-HK002400		Upper Thread Guide C	윗실 가이드 C	1	
N-28	DSC-BJ000200		Screw(11/64" n=40)	윗실 가이드 C 고정나사 (11/64" n=40)	1	
N-29	CMB-HK002500		Upper Thread Guide D	윗실 가이드 D	1	
N-30	DSC-BJ000200		Screw(11/64" n=40)	윗실 가이드 D 고정나사 (11/64" n=40)	1	
N-31	CMB-HK002700		Upper Thread Guide	윗실 걸이	1	
N-32	DSN-AA000700		Nut(15/64" n=28)	윗실 걸이 너트 (15/64" n=28)	1	
N-33	CMB-HK002300		Arm Thread Guide	암실 안내	1	
N-34	DSC-BF001000		Screw(11/64" n=40)	암실 안내 고정나사 (11/64" n=40)	2	
N-35	PPP-CA001200		Thread Release Air Cylinder	실늦추기 에어 실린더	1	
N-36	PPP-AA000100		Air Cylinder Fitting	실늦추기 에어 실린더 피팅	2	
N-37	PTC-AH000100		Code Holder(5N)	코드 홀더(5N)	1	
N-38	DSC-BJ000200		Screw(11/64" n=40)	코드 홀더 쥘나사(11/64" n=40)	1	
N-39	CTR-BJ001100		Tension Release Cylinder Suppoer Plate	실늦추기 실린더 지지판	1	
N-40	DSC-BF001000		Screw(11/64" n=40)	실늦추기 실린더 지지판 고정나사 (11/64" n=40)	2	
N-41	DWS-AA000600		Washer	고정나사 와셔	2	
N-42	AMB-PS001700		Lower Thread Guide Pipe A	밑실 안내 파이프 A	1	
N-43	DSC-CB000700		Screw(M5×L=6 )	밑실 안내 파이프 A 쥘나사 (M5×L=6 )	1	
N-44	CMB-HK003000		Lower Thread Guide	밑실 안내	1	
N-45	DSC-BJ000200		Screw(11/64" n=40)	밑실 안내 고정나사 (11/64" n=40)	1	
N-46	CMB-BQ000300		Lower Thread Guide Pipe B	밑실 안내 파이프 B	1	
N-47	CMB-BG000200		Lower Thread Guide Pipe Holder	실 안내 파이프 잡이	2	
N-48	DSC-BJ000200		Screw(11/64" n=40)	실 안내 파이프 잡이 고정나사 (11/64" n=40)	1	
N-49	CMB-HK002800	-01	Gimp Thread Guide A	심사 안내 A	1	
N-50	DSC-BJ000200	-01	Screw(11/64" n=40)	심사 안내 A 쥘나사 (11/64" n=40)	1	
N-51	CTA-BB000200	-01	Gimp Thread Guide Lever Bracket	심사 안내 레버 브라켓	1	
N-52	DSC-BF001000	-01	Screw(11/64" n=40)	심사 안내 레버 브라켓 쥘나사 (11/64" n=40)	2	
N-53	DSP-AC002500	-01	Spring For Gimp Thread Guide Lever	심사 안내 레버 스프링	1	
N-54	DSP-AB002100	-01	Spring For Gimp Thread Guide Lever Driving Plate	심사 안내 레버 작동판 스프링	1	
N-55	CTA-BJ000500	-01	Driving Plate For Gimp Thread Guide Lever	심사 안내 레버 작동판	1	
N-56	DSC-FA008000	-01	Stud For Gimp Thread Guide Lever	심사 안내 레버 단나사	1	
N-57	DSC-FA007900	-01	Stud For Gimp Thread Guide Lever Driving Plate	심사 안내 레버 작동판 단나사	1	

NOTE: 01 → Long Trimmer(긴 사절형)  
02 → Short Trimmer(짧은 사절형)

# N

## Thread Release & Thread Tension Mechanism

### 실조절 장치 관계

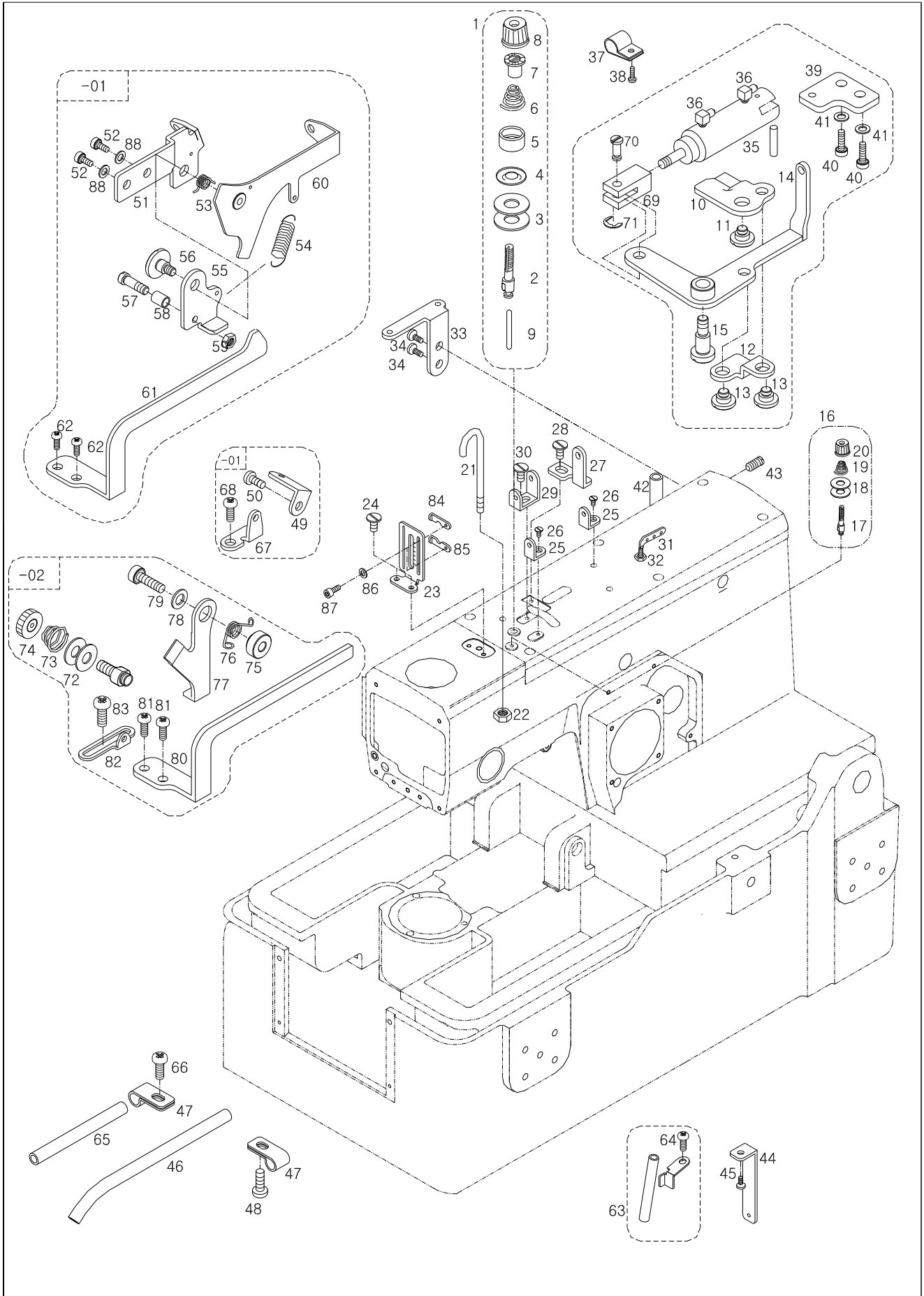



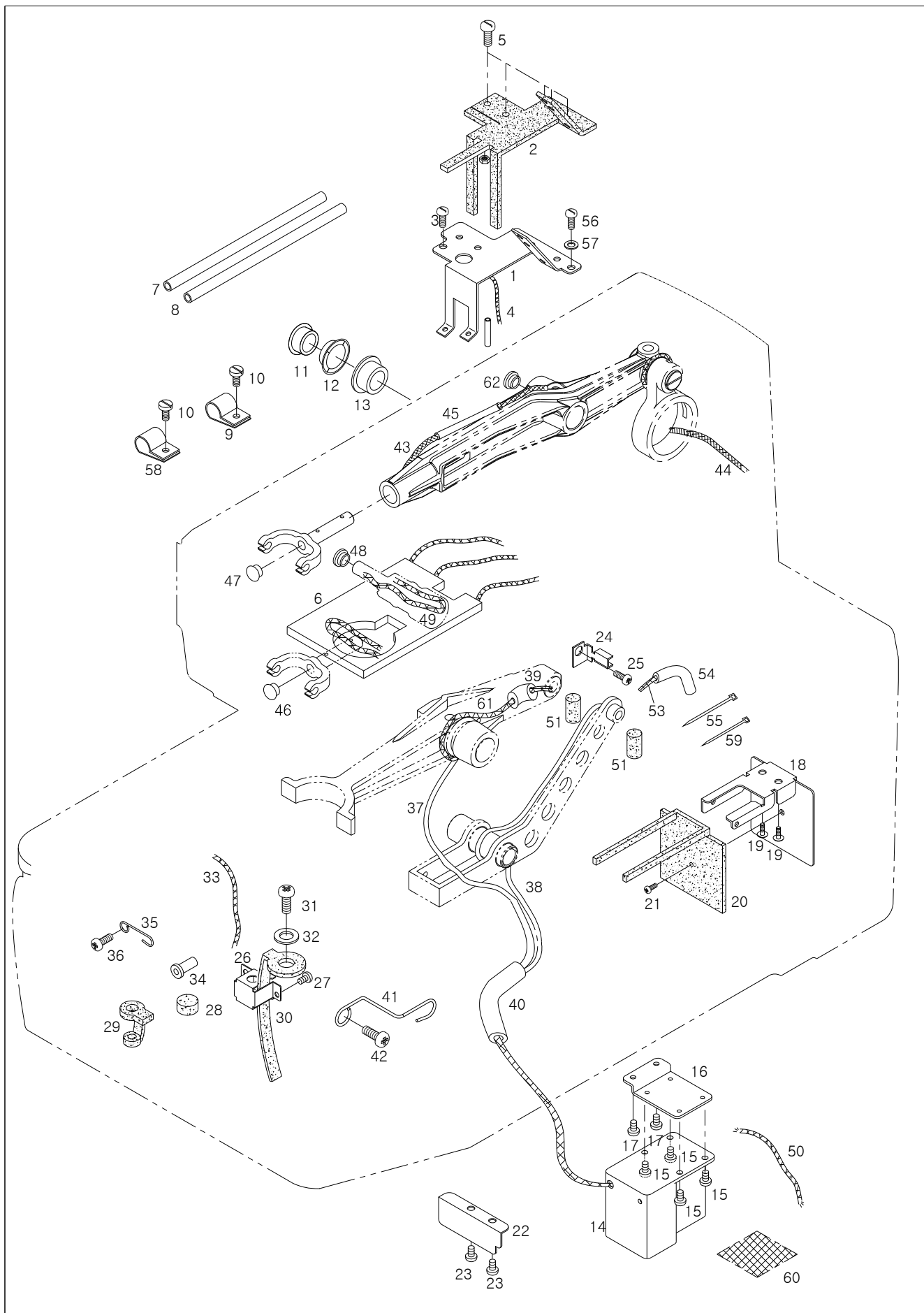

Ref. No.	Parts No.	Note	Name of Parts	품 명	Q'ty	Assembly
O-1	CLB-BG003000		Support For Oil Felt Upper Shaft	상축 급유 헬트 지지대	1	
O-2	CLB-JL002800		Oil Felt For Upper Shaft	상축 급유 헬트	1	
O-3	DSC-BA000900		Screw(9/64" n=40)	지지대 첩나사(9/64" n=40)	1	
O-4	CLB-JD000300		Oil Wick	헬트 급유 유심	1	
O-5	DSC-BA000900		Felt Fixed Screw(9/64" n=40)	헬트 고정 나사(9/64" n=40)	3	
O-6	CLB-JL003900		Oil Felt For Arm	암 급유 헬트	1	
O-7	CLB-JG000300		Hose A	유심 호스 A	1	
O-8	CLB-JG000300		Hose B	유심 호스 B	1	
O-9	PTC-AH000500		Code Holder(3N)	코드홀더(3N)	3	
O-10	DSC-BA000900		Screw(9/64" n=40)	코드홀더 첩나사	4	
O-11	CLB-JJ000100		Oil Winder	유창	1	
O-12	CLB-JN000100		Oil Gauge	오일 게이지	1	
O-13	CLB-FA000100		Oil Window Rubber Ring	유창 고무링	1	
O-14	CLB-JB000300		Oil Tank Ass'y	오일탱크(조)	1	
O-15	DSC-BJ000200		Screw(9/64" n=40)	오일탱크(조) 첩나사(9/64" n=40)	4	
O-16	CLB-BB000500		Oil Tank Bracket	오일 탱크 브라켓	1	
O-17	DSC-BJ000200		Screw(11/64" n=40)	브라켓 첩나사(11/64" n=40)	2	
O-18	CLB-BG002400		Support For Oil Felt Lower Shaft	하축 급유 헬트 지지대	1	
O-19	DSC-BJ000200		Screw(11/64" n=40)	지지대 첩나사(11/64" n=40)	2	
O-20	CLB-JL003100		Oil Felt For Lower Felt	하축 급유 헬트	1	
O-21	DSC-BA000900		Felt Fixed Screw(9/64" n=40)	헬트 고정 나사(9/64" n=40)	1	
O-22	CLS-BJ000300		Cover For Lower Shaft Cam	하축 캠 커버	1	
O-23	DSC-BJ000200		Screw(11/64" n=40)	하축 캠 커버 첩나사(11/64" n=40)	2	
O-24	CLB-BG002900		Wick Support For Looper Lonk	루퍼 링크 유심 지지대	1	
O-25	PSC-BA000500		Screw(M3×L5)	지지대 첩나사(M3×L5)	1	
O-26	CLB-BG002800		Felt Support	헬트 지지대	1	
O-27	PSC-BA000500		Screw(M3×L3.5)	헬트 지지대 첩나사(M3×L3.5)	1	
O-28	CLB-JL003700		Oil Felt For Felt Support	헬트 지지대 급유 헬트	1	
O-29	CLB-JL003800		Oil Felt For Looper Driving Shaft	루퍼 구동축 급유 헬트	1	
O-30	CLB-JL003600		Oil Felt For Looper Base	루퍼 베이스 급유 헬트	1	
O-31	PSC-BA000400		Oil Felt Fix Screw(M3×L6)	루퍼 베이스 급유 헬트 고정 나사(M3×L6)	1	
O-32	PWS-AA000200		Washer	고정 나사 와셔	1	
O-33	CLB-JD000300		Wick For Looper Base	루퍼 베이스 급유 유심	1	
O-34	CLB-JG000700		Oil Tube For Looper Base	루퍼 베이스 유심 호스	1	
O-35	CLB-BH001100		Wick Holder A	유심잡이 A	1	
O-36	PSC-BA000400		Screw(M3×L5)	유심잡이 A 첩나사(M3×L5)	1	
O-37	CLB-JD000300		Oil Wick	루퍼 링크 급유 유심	1	
O-38	CLB-JD000300		Oil Wick	캠 링크 급유 유심	1	
O-39	CLB-JG000300		Hose	루퍼 링크 유심 호스(φ3×φ5)	1	
O-40	CLB-JG000300		Hose	급유 탱크 유심 호스(φ3×φ5)	1	
O-41	CLB-BH001000		Oil Hose Holder	오일 호스 잡이	1	
O-42	DSC-BJ000200		Screw(11/64" n=40)	호스잡이 첩나사(11/64" n=40)	1	
O-43	CLB-JD000300		Oil Wick	바늘대 구동 레버 급유 유심	1	
O-44	CLB-JD000300		Oil Wick	바늘대 구동 릿드 급유 유심	1	
O-45	CLB-JG000300		Hose	바늘대 구동 레버 유심 호스	1	
O-46	DPK-CA000800		Oil Cap	바늘대 구동 기어 축 오일 캡	2	
O-47	DPK-CA000800		Oil Cap	바늘대 연결 링크 오일 캡	1	
O-48	DPK-CA000700		Oil Cap	지그재그 요동 축 오일 캡	1	
O-49	CLB-JD000300		Oil Wick	지그재그 요동 축 급유 유심	1	
O-50	CLB-JD000300		Oil Wick	배유 유심	1	
O-51	CLB-JL003000		Oil Felt For Cutter Lever Shaft	커터 레버 축 급유 헬트	2	
O-54	CLB-JG000300		Hose	환류 파이프	1	
O-55	PTC-AG000200		Tie	타이(중)	5	
O-56	DSC-BJ000300		Screw	첩나사	1	
O-57	DWS-AA001100		Washer	평와셔	1	
O-58	PTC-AH000100		Cable Holder(5N)	코드 홀더(5N)	1	
O-59	PTC-AG000100		Tie	타이(소)	55	

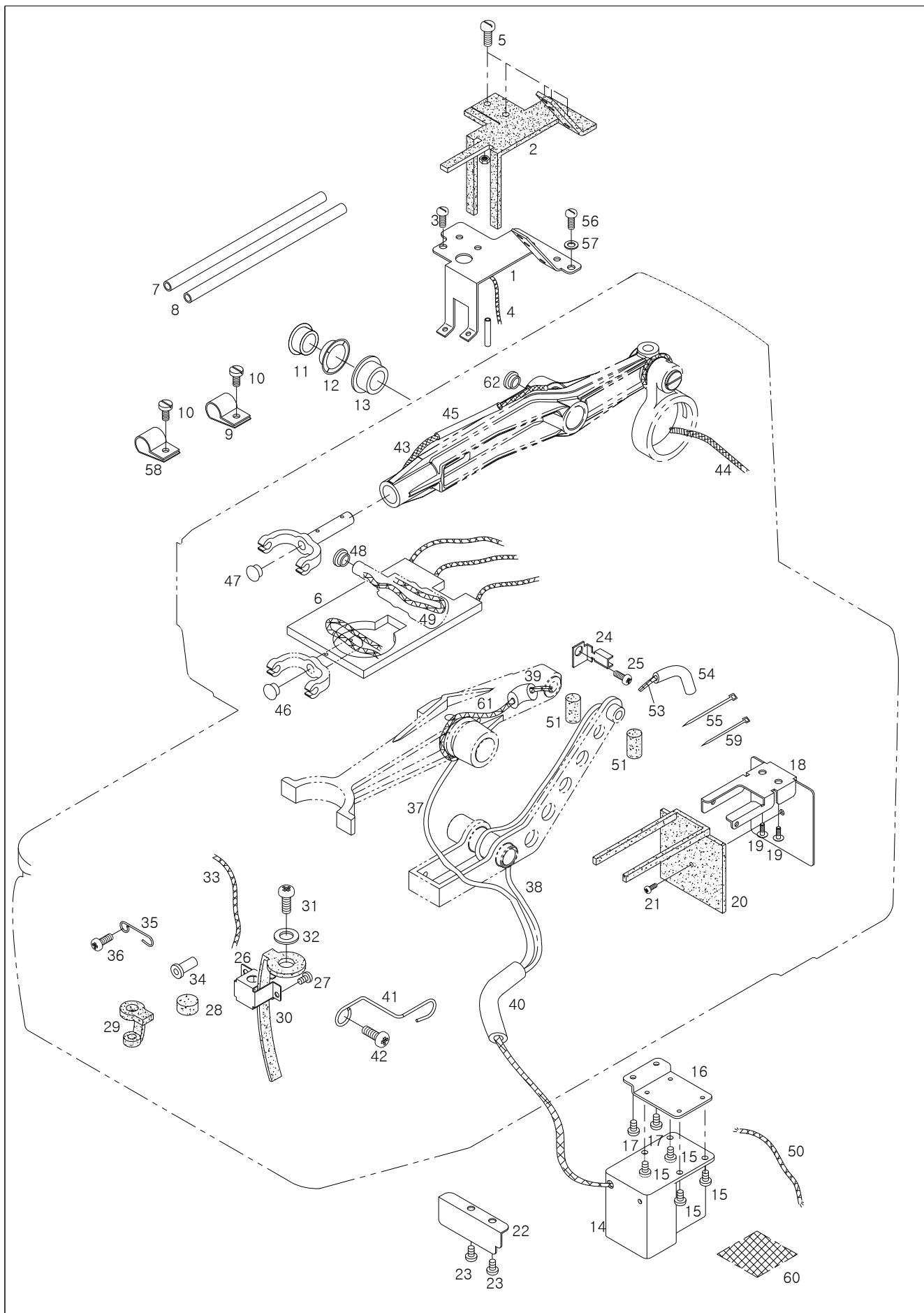



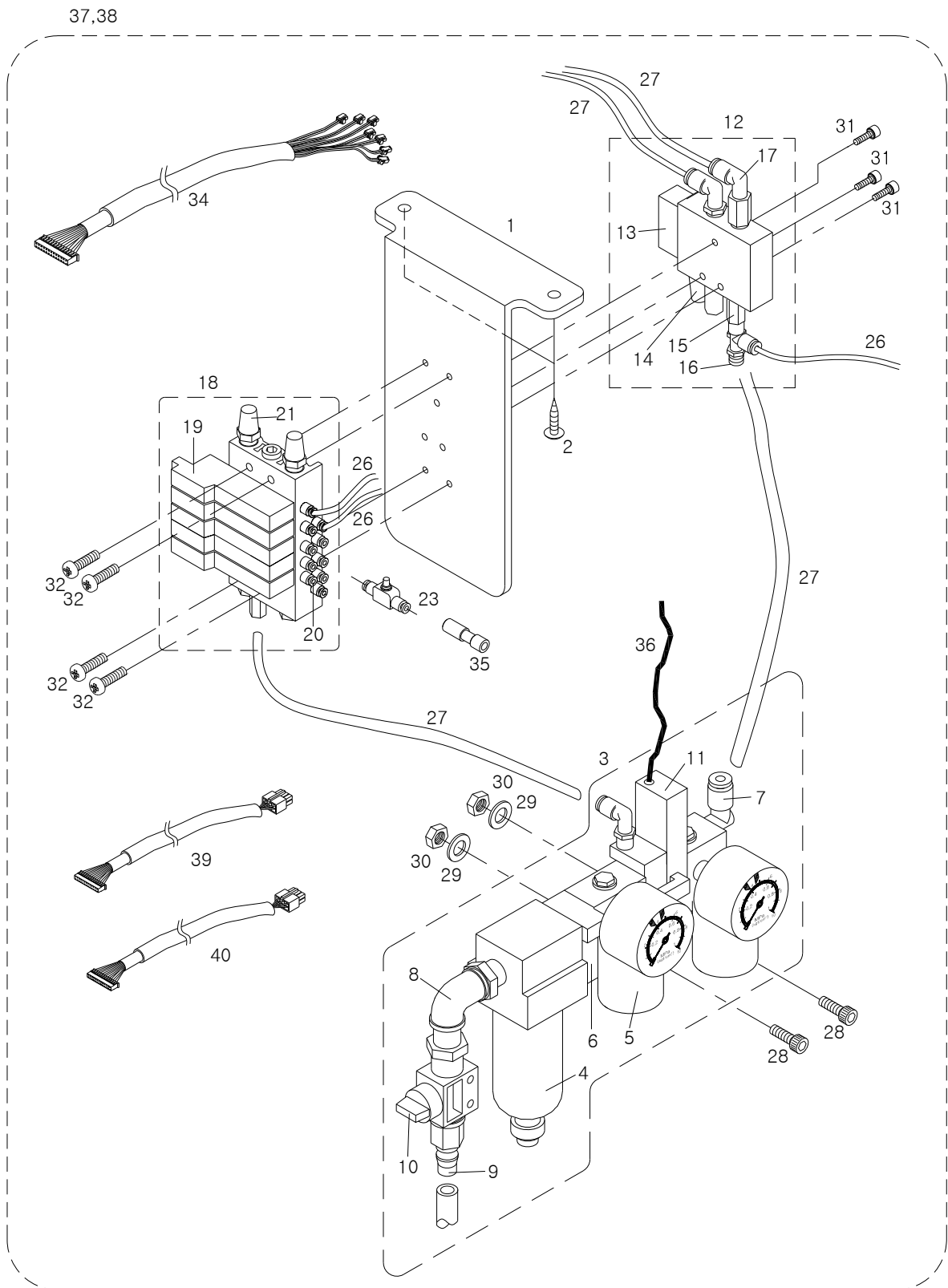



Ref. No.	Parts No.	Note	Name of Parts	품 명	Q'ty	Assembly
P-1	CAR-BB000300		Manifold Bracket	매니폴드 브라켓	1	
P-2	PSC-DA000100		Screw Nail	매니폴드 브라켓 고정 나사못	2	
P-3	AAR-PS001100		Filter Regulator ASM	Filter Regulator ASM	1Set	
P-4	PPP-BH000100		Air Unit	에어 유닛	1	
P-5	PPP-BD000200		Regulator	레귤레이터	2	
P-6	PPP-BJ000100		Bracket	브라켓	1	
P-7	PPP-AA001500		Nipple	니플	2	
P-8	PPP-AA002100		Elbow Union	엘보우	1	
P-9	PPP-AA002200		Coupling	커플링	1	
P-10	PPP-AG000100		Finger Valve	핑거밸브	1	
P-11	PPP-BG000200		Air Presser Switch	압력 스위치	1	
P-12	AAR-PS000900		Air Solenoid Valve ASM (A)	Air Solenoid Valve ASM (A)	1Set	
P-13	PPP-BA000500		Solenoid Valve	솔레노이드 밸브	1	
P-14	PPP-AB000300		Presser Gauge	배기 조절 밸브	2	
P-15	PPP-AB001800		Nipple	니플	1	
P-16	PPP-AA001700		Elbow Union B	엘보우 A	1	
P-17	PPP-AA001600		Elbow Union A	엘보우 B	3	
P-18	AAR-PS001000		Air Solenoid Valve ASM (B)	Air Solenoid Valve ASM (B)	1Set	
P-19	PPP-BA000600		Solenoid Valve	솔레노이드 밸브	5	
P-20	PPP-BB000300		Manifold Block	매니폴드 블록	1	
P-21	PPP-BC000100		Silence	소음기	2	
P-22	PPP-AA001900		Nipple	니플	1	
P-23	PPP-AB000200		Speed Controller	스피드 컨트롤러	4	
P-26	PPP-AD000100		Air Tube( $\phi$ 4)	Air Tube( $\phi$ 4)	-	
P-27	PPP-AD000300		Air Tube( $\phi$ 10)	Air Tube( $\phi$ 10)	-	
P-28	PSC-AC003900		Filter Regulator ASM. Screw(M5 $\times$ L10)	Filter Regulator ASM. 고정나사(M5 $\times$ L10)	2	
P-29	PWS-AA000400		Washer	고정나사 와셔	2	
P-30	PSN-AA000200		Nut(M5)	고정나사 너트(M5)	2	
P-31	PSC-BA000200		Solenoid Valve A Screw(M4 $\times$ L35)	Solenoid Valve A 고정나사(M4 $\times$ L35)	3	
P-32	PSC-BA000200		Solenoid Valve B Screw(M4 $\times$ L35)	Solenoid Valve B 고정나사(M4 $\times$ L35)	4	
P-34	CA-000722-00		Pneumatic I/O Cable	공기입출력 케이블	1	
P-35	PPP-AA002000		Straight	스트레이트(양방향)	4	
P-36	CA-000727-00		Cable	공압 압력 센서 케이블	1	
P-37	AS-000382-00		Air Pressure Ass'y	공압(조)	1Set	
P-38	AS-001521-00		Air Pressure Ass'y	공압(조)	1Set	
P-39	CA-000710-00		Cable	스텝모터 중간 연결 케이블	1	
P-40	CA-000721-00		Cable	원점 센서 케이블	1	

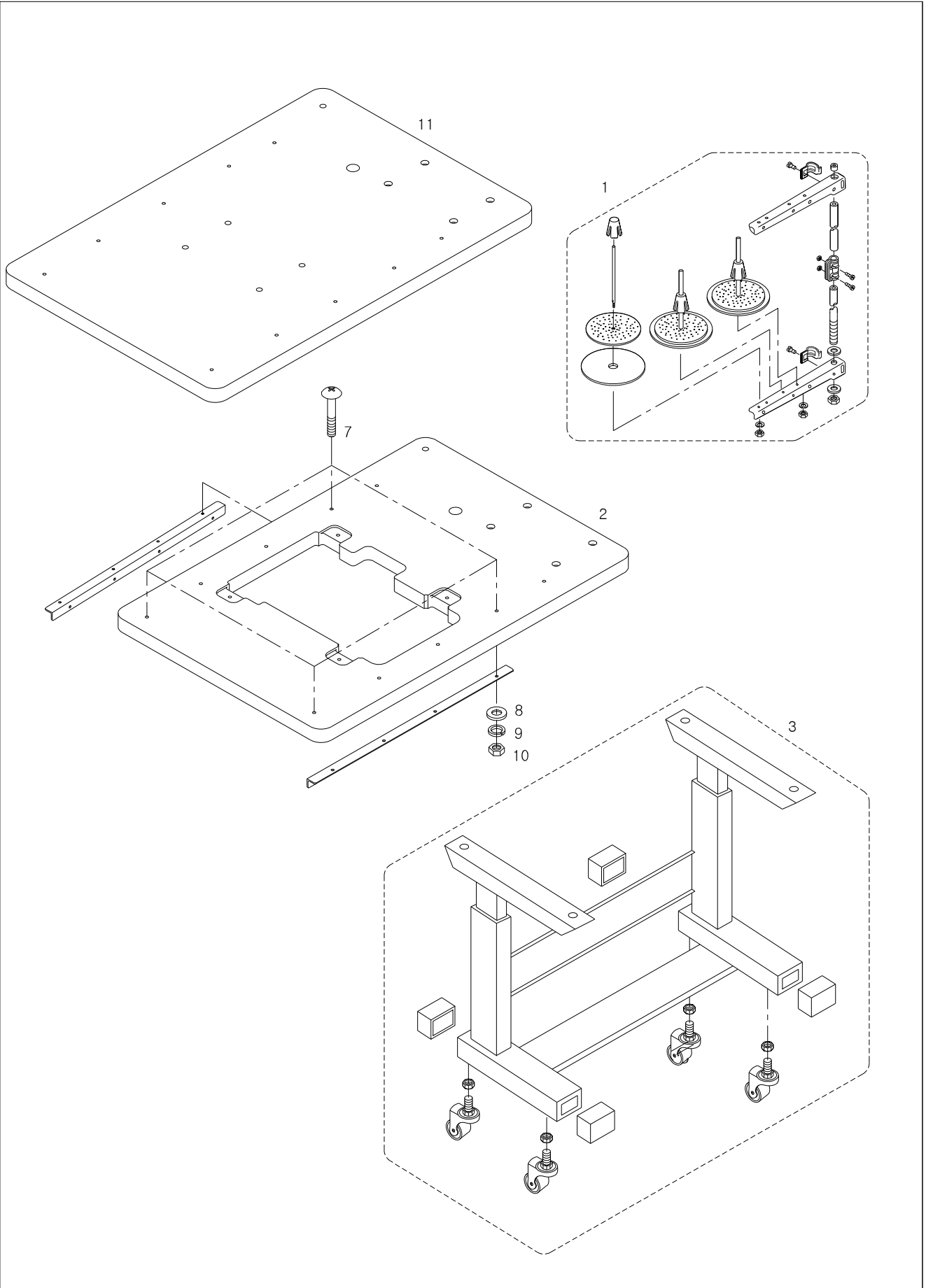



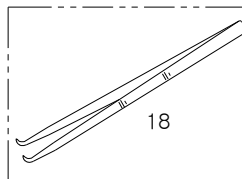
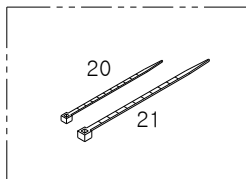
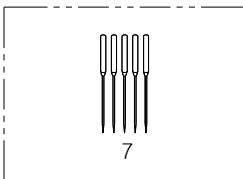
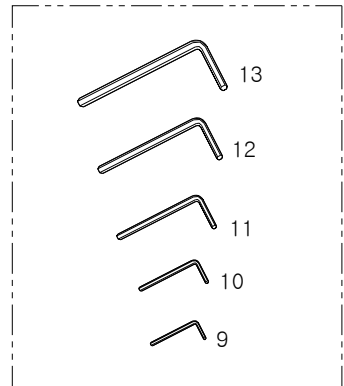
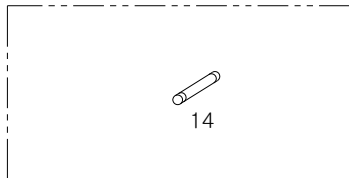
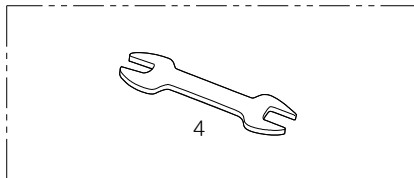
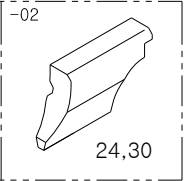
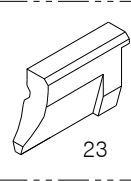
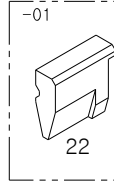
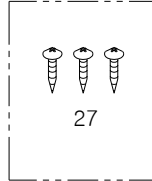
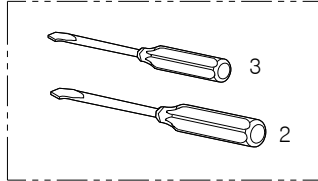
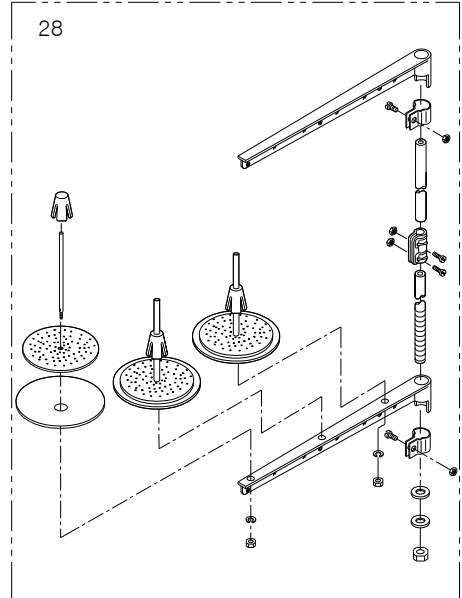
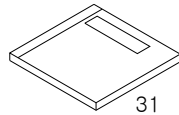
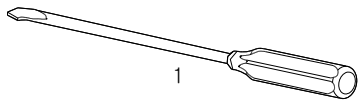
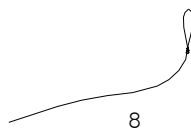
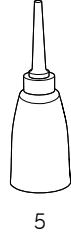
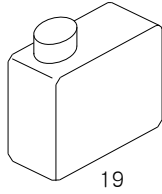
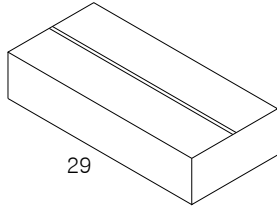



# S

## Hand Switch & Pedal Mechanism

### 핸드 스위치 및 페달 관계

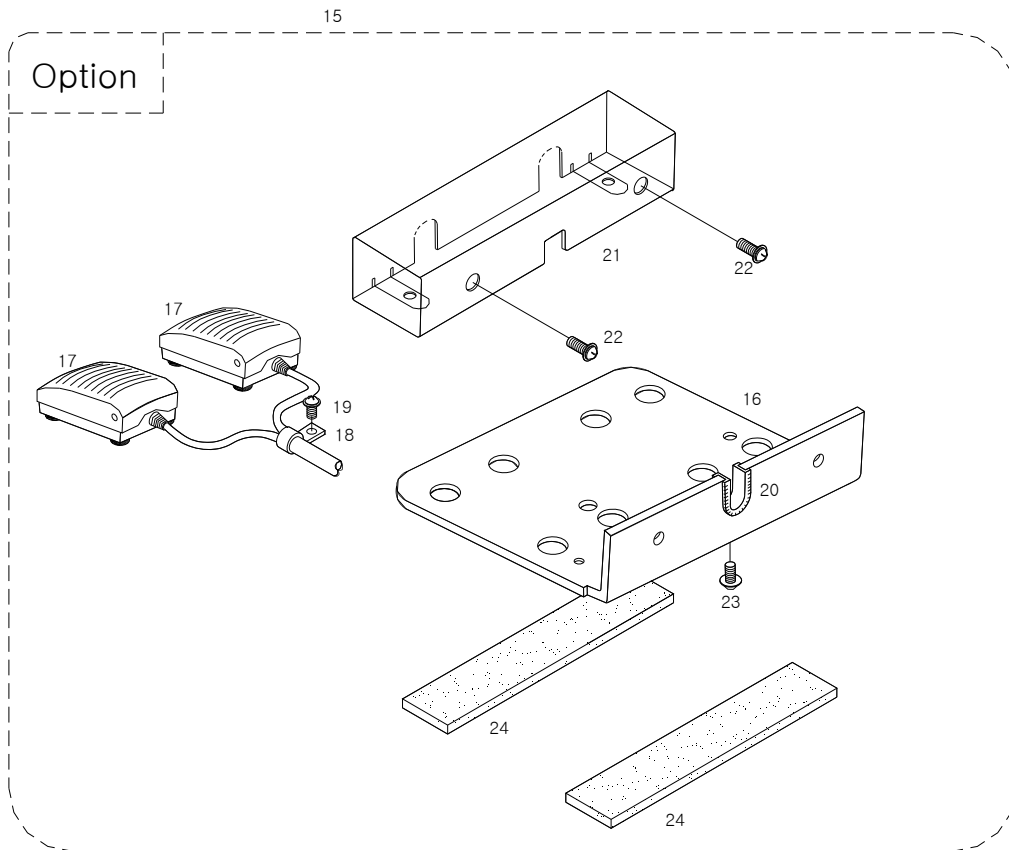
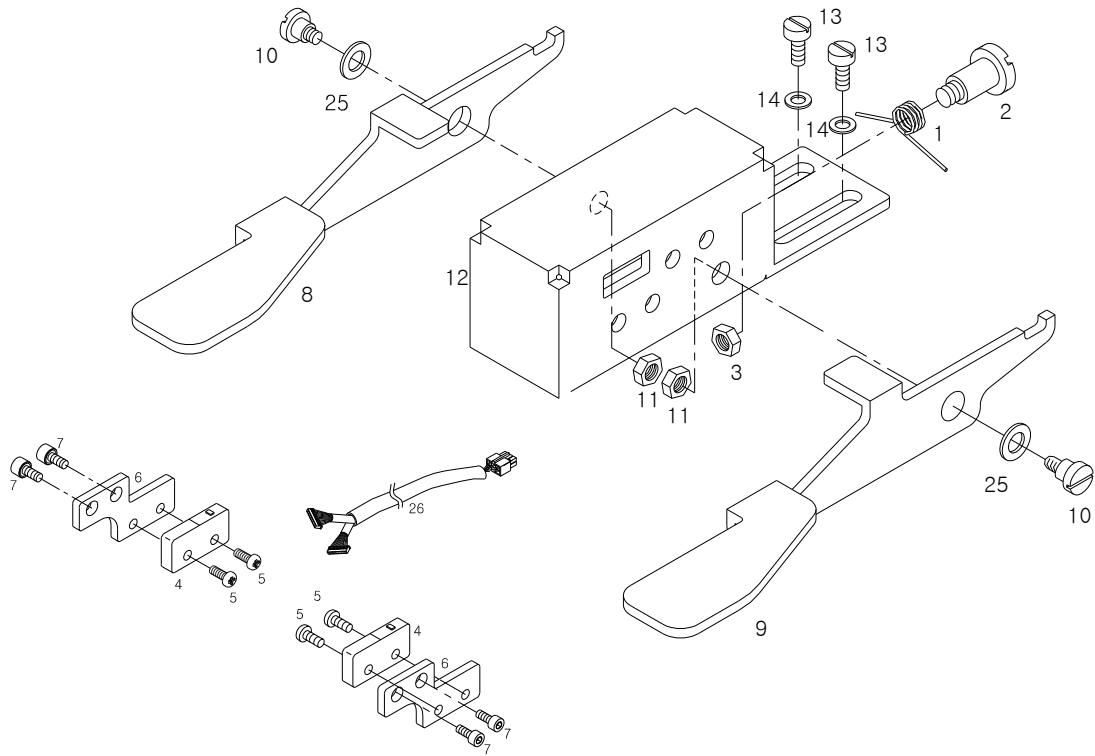



# T

## Control Box Mechanism

### 컨트롤 박스 관계

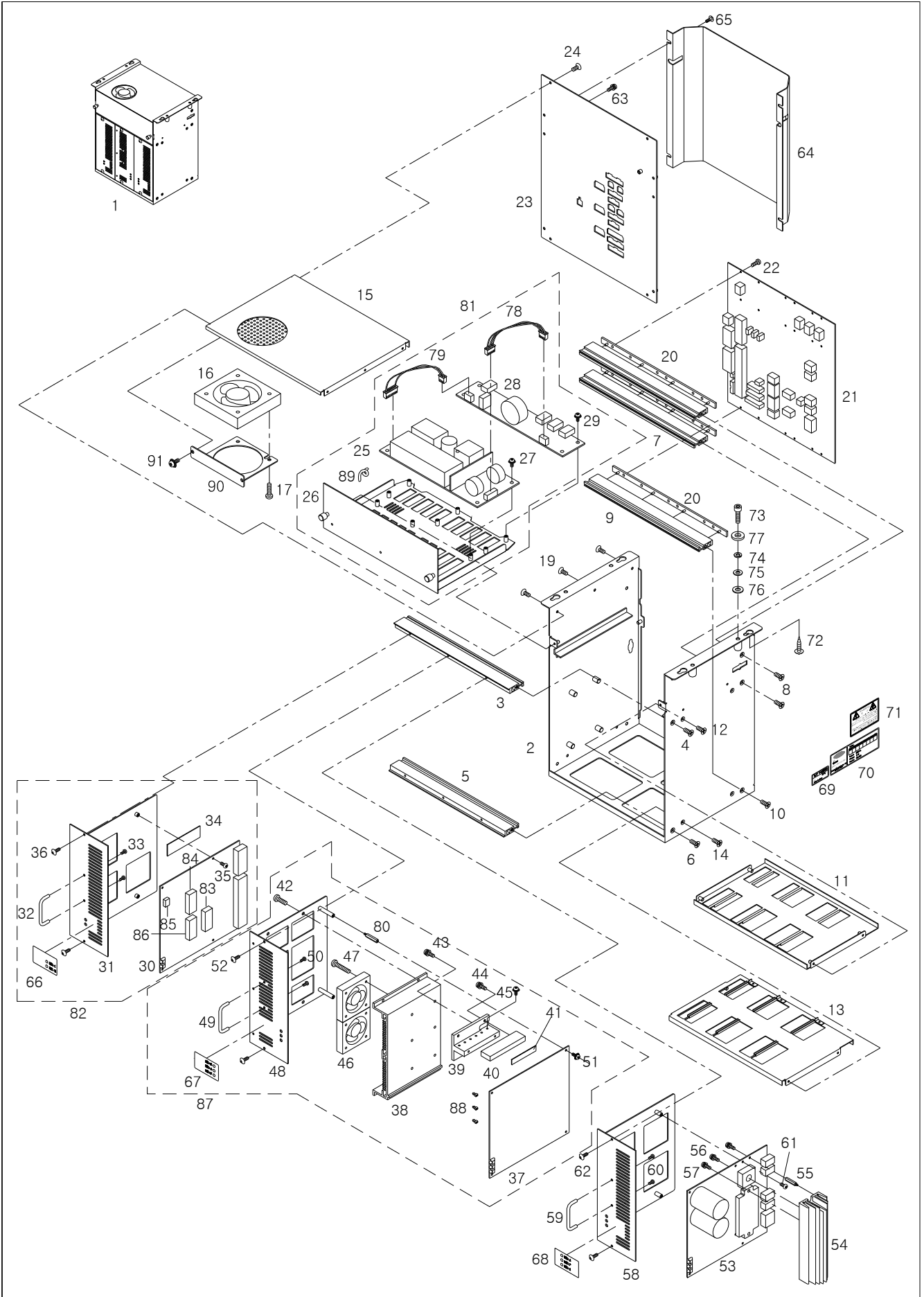





Ref. No.	Parts No.	Note	Name of Parts	품 명	Q'ty	Applied Period
T-1	01-000A-BH6U		Control Box Ass'y	콘트롤 박스(조)	1Set	
T-2	GP-013459-04		Box Body	박스바디	1	Feb.03.10
T-3	GP-008671-01		Front Profile Upper	전면부 프로파일-상	1	
T-4	10-016S-CPT1		Screw(M4×L12)	전면부 프로파일-상 고정나사(M4×L12)	2	
T-5	GP-008672-01		Front Profile Lower	전면부 프로파일-하	1	
T-6	10-016S-CPT1		Screw(M4×L12)	전면부 프로파일-하 고정나사(M4×L12)	2	
T-7	GP-008673-00		Rear Profile Upper	후면부 프로파일-상	2	
T-8	10-016S-CPT1		Screw(M4×L12)	후면부 프로파일-상 고정나사(M4×L12)	4	
T-9	GP-008674-00		Rear Profile Lower	후면부 프로파일-하	1	
T-10	10-016S-CPT1		Screw(M4×L12)	후면부 프로파일-하 고정나사(M4×L12)	2	
T-11	GP-008666-01		Upper Frame	가로지지대-상	1	
T-12	10-004M-SW68		Screw(M3×L5)	가로지지대-상 고정나사(M3×L5)	4	
T-13	GP-008663-01		Lower Frame	가로지지대-하	1	
T-14	10-004M-SW68		Screw(M3×L5)	가로지지대-하 고정나사(M3×L5)	4	
T-15	GP-014587-00		Upper Cover	상면커버	1	
T-16	EA-000114-00		Control Box Fan	콘트롤박스 Fan	1	
T-17	01-002M-AU12		Screw(M4×L35)	콘트롤박스 Fan 고정나사(M4×L35)	4	
T-19	10-004M-SW68		Screw(M3×L5)	상면커버 고정나사(M3×L5)	6	
T-20	GP-008667-00		Insulation Plate	절연 플레이트	3	
T-21	BD-000326-00		Backplane Board	백플레인 보드	1	
T-22	10-020M-SW66		Screw(M3×L12)	백플레인 보드 고정나사(Set)(M3×L12)	18	
T-23	GP-013461-01		Rear Cover	후면커버	1	
T-24	10-004M-SW68		Screw(M3×L5)	후면커버 고정나사(M3×L5)	6	
T-25	EP-000039-00		SMPS	SMPS	1	
T-26	GP-008701-05		SMPS Bracket	SMPS 브라켓	1	
T-27	10-002S-SW66		Screw(M3×L8)	SMPS 고정나사(Set)(M3×L8)	5	
T-28	BD-000203-07		DDC Board	DDC 보드	1	
T-29	10-002S-SW66		Screw(M3×L8)	DDC 보드 고정나사(Set)(M3×L8)	6	
T-30	BD-000325-20		Digital Board	디지털 보드	1	Apr.08.11
	BD-000325-19		Digital Board	디지털 보드	1	Apr.08.11
	BD-000325-18		Digital Board	디지털 보드	1	Nov.01.10
T-31	GP-008668-06		Digital Board Bracket	디지털 보드 브라켓	1	Feb.03.10
T-32	GP-012617-00		Board Bracket Handle	보드 브라켓 손잡이	1	
T-33	10-073S-3701		Screw(M3×L10)	보드 브라켓 손잡이 고정나사(M3×L10)	2	
T-34	GP-007198-00		SMD FET Radiator Sheet	디지털 보드 SMD FET 방열시트	1	
T-35	10-002S-SW66		Screw(M3×L8)	디지털 보드 고정나사(Set)(M3×L8)	4	
T-36	01-001S-NET1		Screw(M3×L6)	디지털 보드 브라켓 고정나사(M3×L6)	2	
T-37	BD-000314-12		Step Board	스텝보드	1	Aug.08.11
	BD-000314-11		Step Board	스텝보드	1	Nov.01.10
	BD-000314-10		Step Board	스텝보드	1	Sep.06.10
	BD-000314-09		Step Board	스텝보드	1	Apr.09.10
T-38	GP-013453-01		Step Board Radiator	스텝 보드 방열판	1	
T-39	GP-013452-01		Step Board Radiator Bracket	스텝 보드 방열 브라켓	3	
T-40	GP-013610-00		Step Board Radiator Sub Bracket	스텝보드 보조 방열 브라켓	3	
T-41	GP-013846-00		Radiator Sheet B	스텝보드 방열시트 (B)	3	
T-42	SC-001272-00		Screw(M4×L8)	스텝보드 방열판 고정나사(M4×L8)	4	
T-43	10-002S-SW66		Screw(M3×L8)	스텝보드 방열 브라켓 고정나사(Set)(M3×L8)	6	
T-44	10-002S-SW66		Screw(M3×L8)	스텝보드 보조 방열 브라켓 고정나사(Set)(M3×L8)	6	
T-45	10-002S-SW66		Screw(M3×L8)	FET 고정나사 (Set)(M3×L8)	36	
T-46	01-005A-BT01		Step Board Fan	스텝보드 팬	2	
T-47	01-017C-DU33		Screw(M4×L25)	스텝보드 팬 고정나사(M4×L25)	4	
T-48	GP-013456-02		Step Board Bracket	스텝 보드 브라켓	1	
T-49	GP-012617-00		Board Bracket Handle	보드 브라켓 손잡이	1	
T-50	10-073S-3701		Screw(M3×L10)	보드 브라켓 손잡이 고정나사(M3×L10)	2	
T-51	10-002S-SW66		Screw(M3×L8)	스텝 보드 고정나사 (Set)(M3×L8)	4	
T-52	01-001S-NET1		Screw(M3×L6)	스텝 보드 브라켓 고정나사(M3×L6)	2	
T-53	BD-000206-09		Main Board	주축보드	1	Nov.01.10

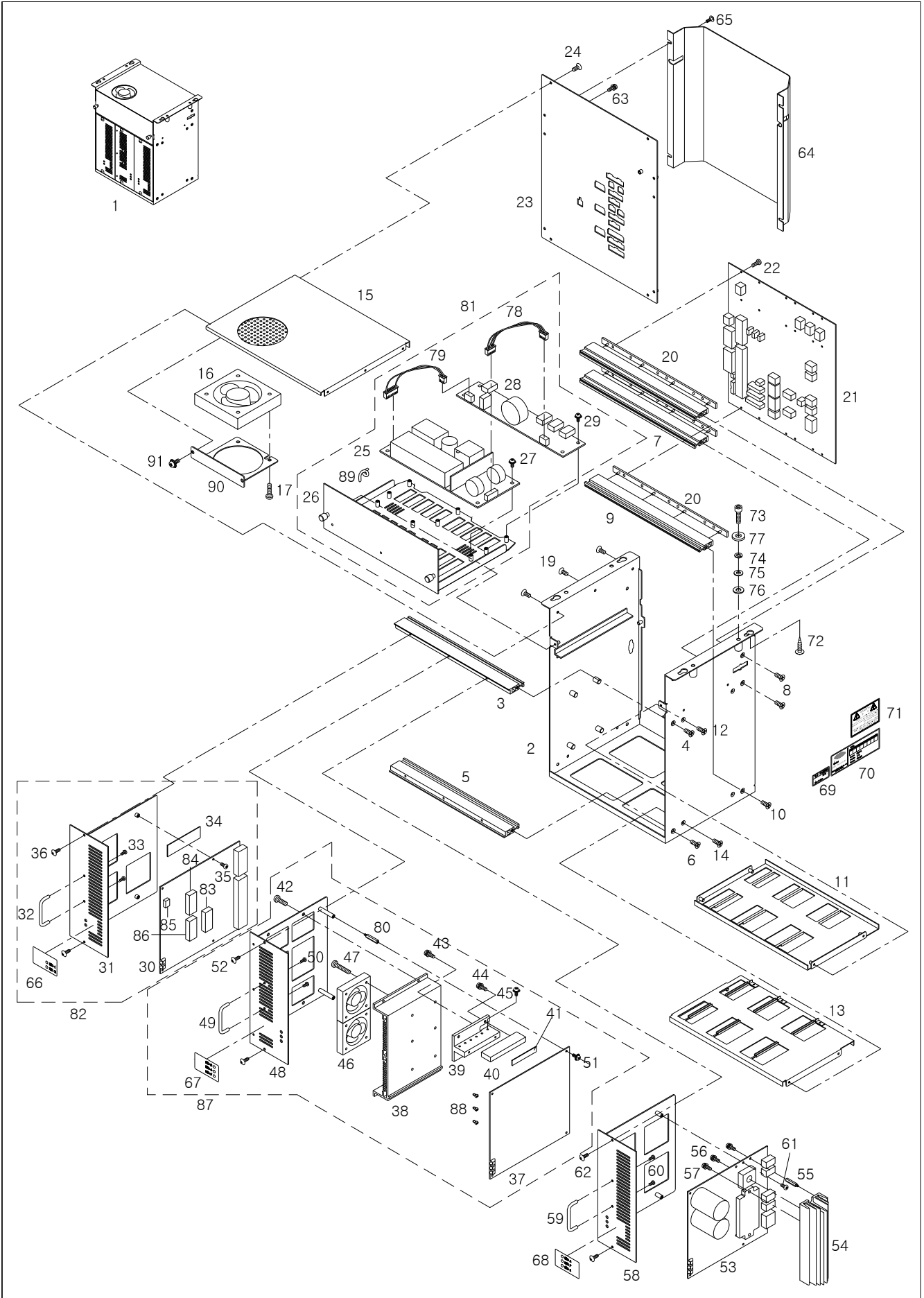

Ref. No.	Parts No.	Note	Name of Parts	품 명	Q'ty	Applied
T-53	BD-000206-08		Main Board	주축보드	1	Apr.02.10
T-54	GP-007203-00		Main Board Radiator	주축 보드 방열판	1	
T-55	10-012M-PT10		Main Board Stud	주축 보드 스토티드(3-5-15)	3	
T-56	01-003S-2070		Screw(M4×L16)	브릿지다이오드 고정나사(Set)(M4×L16)	1	
T-57	10-003M-PT10		Screw(M4×L10)	IPM 고정나사(Set)(M4×L10)	2	
T-58	GP-008670-05		Main Board Bracket	주축 보드 브라켓	1	Feb.03.10
T-59	GP-012617-00		Board Bracket Handle	보드 브라켓 손잡이	1	
T-60	10-073S-3701		Screw(M3×L10)	보드 브라켓 손잡이 고정나사(M3×L10)	2	
T-61	10-002S-SW66		Screw(M3×L8)	주축 보드 고정나사 (Set)(M3×L8)	4	
T-62	01-001S-NET1		Screw(M3×L6)	주축 보드 브라켓 고정나사(M3×L6)	2	
T-63	07-004S-SM5S		Screw(M4×L10)	후면커버 접지나사(Set)(M4×L10)	1	
T-64	GP-008660-01		Cable Cover	케이블 커버	1	
T-65	10-003M-PT01		Screw(M4×L8)	케이블 커버고정나사(M4×L8)	4	
T-66	GP-007711-00		Digital Board Sticker	디지털 보드 스티커	1	
T-67	GP-013457-00		Step Board Sticker	스텝 보드 스티커	1	
T-68	GP-007713-00		Main Board Sticker	주축 보드 스티커	1	
T-69	GP-047599-00		QC Passed Sticker	QC Passed 스티커	1	Nov.04.09
T-70	GP-013874-00		Voltage Sticker	전압사양 스티커	1	
T-71	09-012S-CE53		Caution Sticker	어스스티커	1	
T-72	04-001C-SE50		Screw(ST5×L16)	콘트롤 박스 고정나사 (A)(ST4×L8)	4	
T-73	10-001M-5030		Screw(M6×L50)	콘트롤 박스 고정나사 (B)(M6×L50)	4	
T-74	10-003S-SW66		Spring Washer(M6)	스프링 와셔(M6)	4	
T-75	10-004S-SW66		Washer(M6)	평와셔(M6)	4	
T-76	91-001C-BT10		Urethane Washer	우레탄 와셔	4	
T-77	91-001C-PT10		Table Washer	테이블 와셔	4	
T-78	CA-000342-00		SMPS Connecting Cable1	SMPS 연결 케이블1(입력)	1	
T-79	CA-000343-00		SMPS Connecting Cable2	SMPS 연결 케이블2(출력)	1	
T-80	SC-000502-00		Step Board Stud	스텝보드 고정 스토티드(M3-30.5-5)	4	
T-81	01-100B-BH6U		BH6U SMPS Bracket(set)	BH6U SMPS 브라켓(조)	1	
T-82	01-200B-BH6U		BH6U Digital Bracket(set)	BH6U 디지털 브라켓(조)	1	
T-83	03-001A-ZIZA		IC AT28C256-15PUEEPROM	IC AT28C256-15PUEEPROM	1	
T-84	03-002A-BH30		IC AM27C010(M27C1001)	IC AM27C010(M27C1001)	1	
T-85	16-016A-SC53		IC AT24C04-10PU-2.7	IC AT24C04-10PU-2.7	1	
T-86	16-103A-SC53		IC-GAL22V10D-25LPN	IC-GAL22V10D-25LPN	1	
T-87	01-300B-BH63		Step B/D Bracket(set)	Step B/D 브라켓(조)	1	
T-88	CA-002911-00		Jumper Cap(Red)	점퍼 캡(레드)	3	
T-89	EP-000207-00		Cable Holder(50mm)	케이블 잡이(50mm)	1	
T-90	GP-027061-00		Fan Bracket	팬 브라켓	1	
T-91	SC-000683-00		Screw(M3×L8)	팬 브라켓 고정나사	2	

# U

## Operation Box Mechanism

### 오퍼레이션 박스 관계

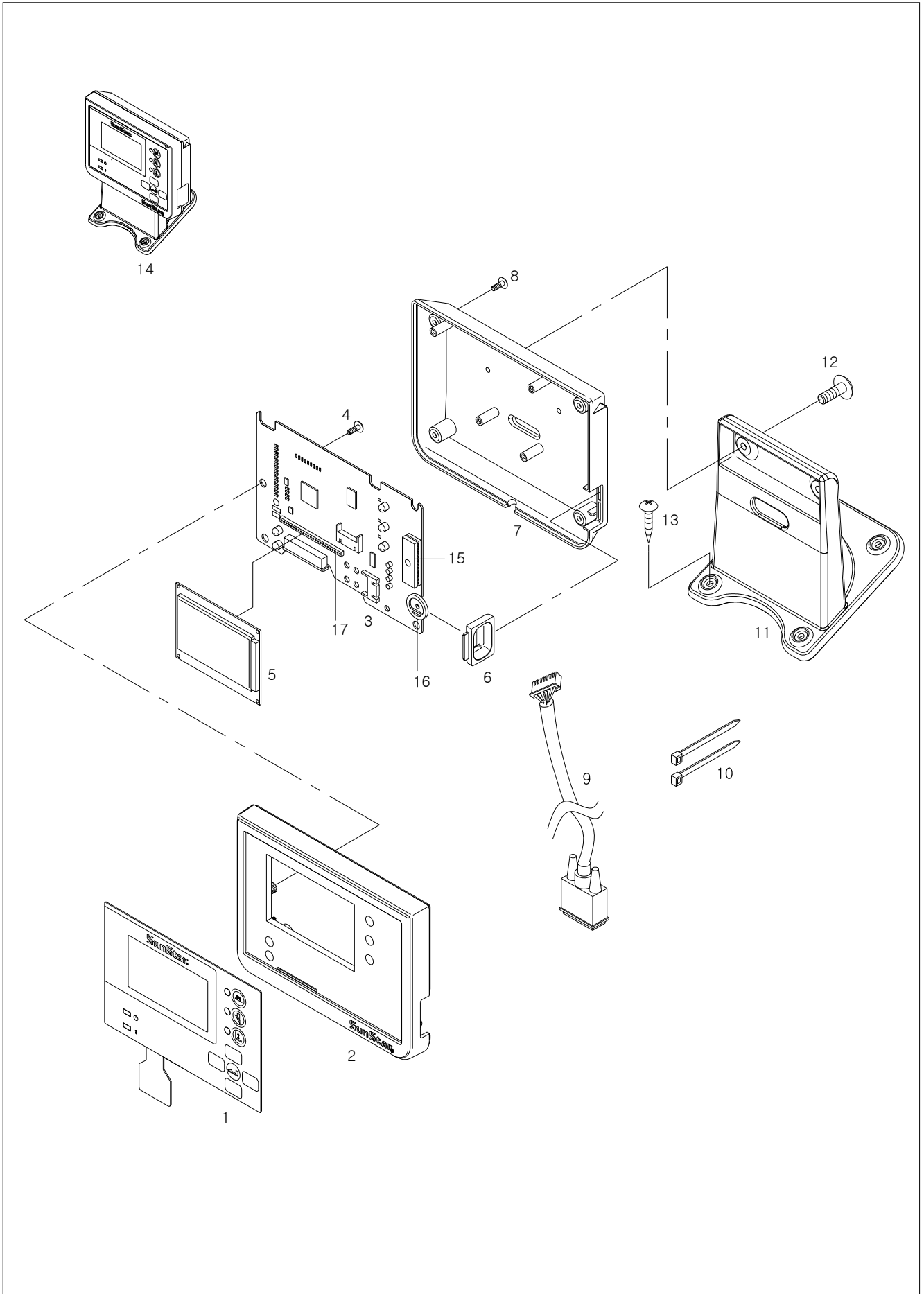



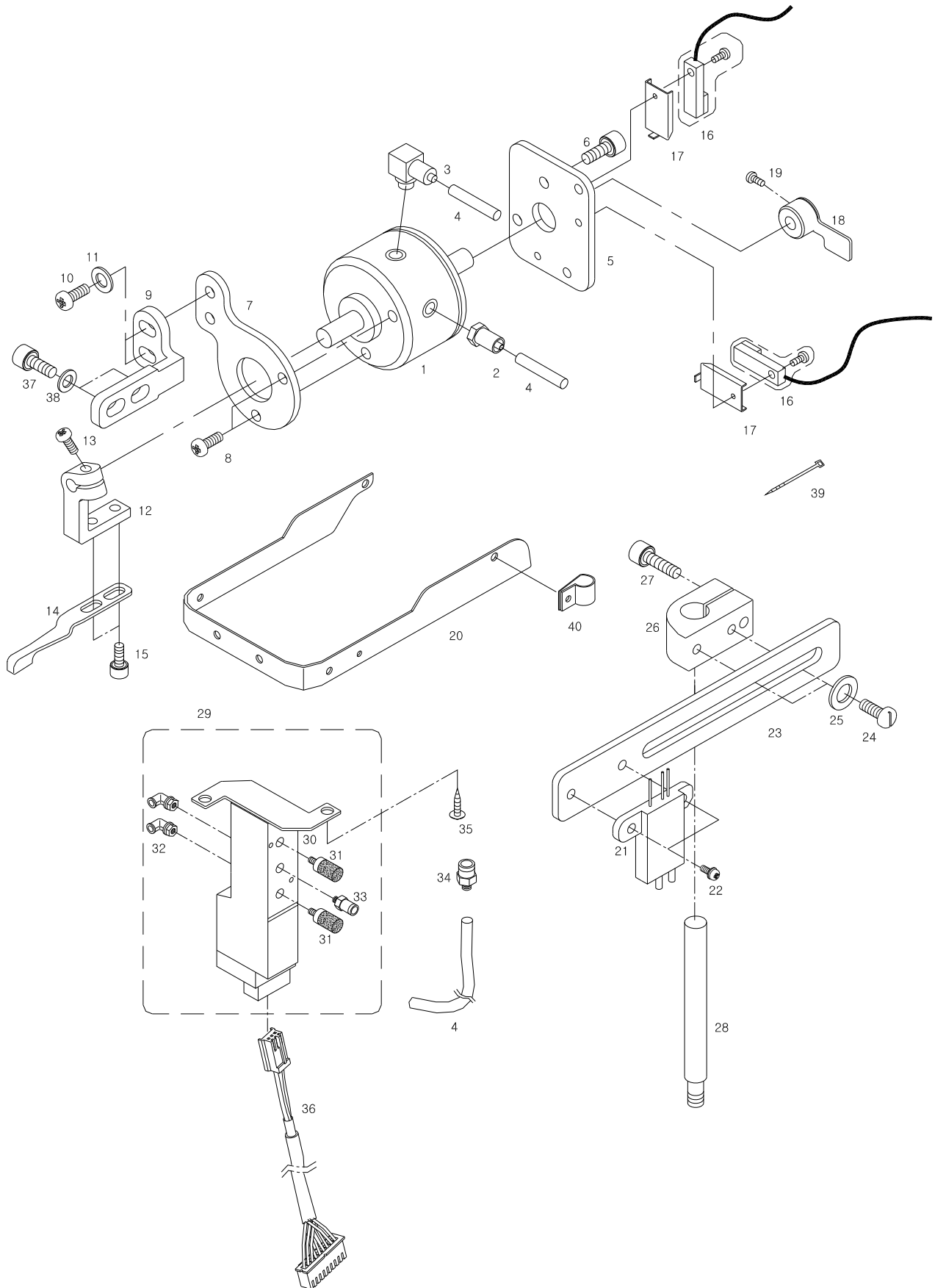

Ref. No.	Parts No.	Note	Name of Parts	품명	Q'ty	Assembly
V-1	GP-004859-00		Rotary Air Cylinder	로터리 에어 실린더	1	
V-2	PPP-AA000100		Air Cylinder Fitting A	에어 실린더 피팅 A	1	
V-3	PPP-AA000200		Air Cylinder Fitting B	에어 실린더 피팅 B	1	
V-4	PPP-AD000100		Air Tube(φ4)	에어 호스(φ4)	-	
V-5	GP-001957-00		Mounting Plate For Cylinder	실린더 부착판	1	
V-6	03071SC-A001		Screw(M3×L15)	실린더 부착판 체결나사(M3×L15)	2	
V-7	GP-001960-00		Setting Plate For Cylinder	실린더 셋팅판	1	
V-8	PSC-BA000400		Screw(M3×L5)	실린더 셋팅판 체결나사(M3×L5)	2	
V-9	GP-001964-00		Support Plate For Cylinder	실린더 지지판	1	
V-10	DSC-BA000100		Screw(9/64" n=40)	실린더 지지판 체결나사(9/64" n=40)	2	
V-11	PWS-AA001000		Washer	실린더 지지판 체결나사 와셔	2	
V-12	GP-001963-00		Hammer Setting Lever	해머 셋팅 레버	1	
V-13	DSC-BJ000300		Screw(9/64" n=40)	해머 셋팅 레버 체결나사(9/64" n=40)	1	
V-14	GP-001962-00		Hammer Plate(7mm)	해머 판(7mm)	1	
V-15	PSC-AC013600		Screw(M3×L5)	해머 판 체결나사(M3×L5)	2	
V-16	GP-004727-00		Sensor Ass'y	센서(조)	2	
V-17	GP-001958-00		Sensor Bracket	센서 브라켓	2	
V-18	GP-001959-00		Sensor Detecting Plate	센서 감지판	1	
V-19	DSC-BJ001100		Screw(9/64" n=40)	센서 감지판 체결나사(9/64" n=40)	1	
V-20	GP-001965-00		Cover For Needle Bar Timing Belt(B)	바늘대 타이밍 벨트 커버(B)	1	
V-21	GP-004728-00		Photo Sensor Ass'y	포토 센서(조)	1	
V-22	PSC-BA000400		Screw(M3×L5)	포토 센서 체결나사(M3×L5)	2	
V-23	GP-001961-00		Setting Plate For Sensor	센서 셋팅판	1	
V-24	DSC-BJ000200		Screw(11/64" n=40)	셋팅 축 잡이 체결나사(11/64" n=40)	2	
V-25	DWS-AA000600		Washer	셋팅 축 잡이 체결나사 와셔	2	
V-26	GP-001093-00		Holder For Setting Shaft	셋팅 축 잡이	1	
V-27	PSC-AC003700		Screw(M5×L20)	셋팅 축 체결나사(M5×L20)	1	
V-28	GP-006042-00		Shaft For Sensor Setting	센서 셋팅 축	1	
V-29	AS-001290-00		Air Solenoid Valve ASM.	에어 솔레노이드 밸브(조)(C)	1Set	
V-30	GP-005980-00		Solenoid Valve	솔레노이드 밸브	1	
V-31	PPP-BC000200		Silence	소음기	2	
V-32	PPP-AA000100		Hose Nipple A	호스 니플 A	2	
V-33	PPP-AA000200		Hose Nipple B	호스 니플 B	1	
V-34	GP-006037-00		Nipple	니플	1	
V-35	91-002S-1067		Screw Nail	솔레노이드 밸브 브라켓 고정 나사못	2	
V-36	GP-005979-00		Pneumatic I/O Cable	공압 입출력 케이블(조)	1Set	
V-37	PSC-AC000200		Screw(M3×L5)	스페셜 라펠 커팅 장치 고정나사(M4×L10)	2	
V-38	PWS-AA001000		Washer	스페셜 라펠 커팅 장치 고정나사 와셔	2	
V-39	PTC-AG000200		Cable Tie(S)	케이블 타이(小)	4	
V-40	PTC-AH000100		Code Holder(5N)	코드 홀더(5N)	1	

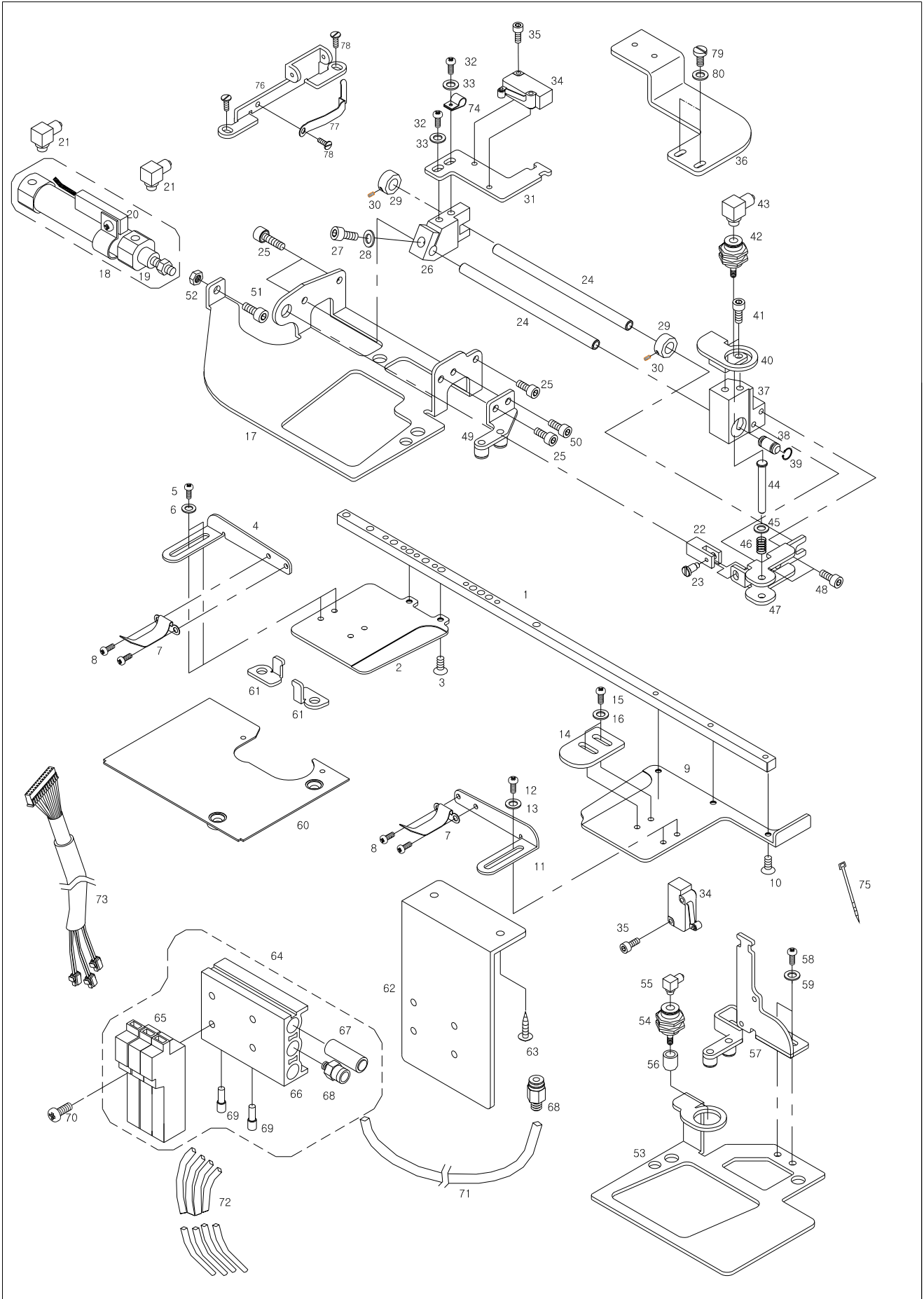



Ref. No.	Parts No.	Note	Name of Parts	품 명	Q'ty	Assembly
W-1	GP-002037-00		Cloth Feed Bar	천 이송바	1	
W-2	GP-002038-00		Cloth Feed Plate(L)	천 이송판(좌)	1	
W-3	PSC-BB000700		Screw(M3×L6)	천 이송판(좌) 쥘나사(M3×L6)	2	
W-4	GP-002039-00		Cloth Setting Guide(L)	천 셋팅 가이드(좌)	1	
W-5	SC-000326-00		Screw(M4×L4)	천 셋팅 가이드(좌) 쥘나사(M4×L4)	2	
W-6	PWS-AA000900		Washer	천 셋팅 가이드(좌) 와셔	2	
W-7	GP-002040-00		Cloth Setting Spring Plate	천 셋팅 스프링판	2	
W-8	PSC-BA000400		Screw(M3×L5)	천 셋팅 스프링판 쥘나사(M3×L5)	4	
W-9	GP-002041-00		Cloth Feed Plate(R)	천 이송판(우)	1	
W-10	PSC-BB000700		Screw(M3×L6)	천 이송판(우) 쥘나사(M3×L6)	3	
W-11	GP-002042-00		Cloth Setting Guide(R)	천 셋팅 가이드(우)	1	
W-12	SC-000326-00		Screw(M4×L4)	천 셋팅 가이드(우) 쥘나사(M4×L4)	2	
W-13	PWS-AA000900		Washer	천 셋팅 가이드(우) 와셔	2	
W-14	GP-002043-00		Cloth Setting Guide	천 셋팅 가이드	1	
W-15	SC-000327-00		Screw(M4×L5)	천 셋팅 가이드 쥘나사(M4×L5)	2	
W-16	PWS-AA000900		Washer	천 셋팅 가이드 와셔	2	
W-17	GP-002044-00		Feed Base(L)	이송 베이스(좌)	1	
W-18	AS-001622-00		Cloth Feed Air Cylinder Ass'y	천 이송 에어 실린더(조)	1Set	
W-19	GP-005994-00		Cloth Feed Air Cylinder	천 이송 에어 실린더	1	
W-20	GP-002376-00		Cylinder Auto Switch	실린더 오토 스위치	1	
W-21	PPP-AA000100		Air Cylinder Fitting	에어 실린더 피팅	2	
W-22	GP-002045-00		Cloth Feed Cylinder Rod	천이송 실린더 로드	1	
W-23	GP-002046-00		Cloth Feed Cylinder Rod Stud Screw	천이송 실린더 로드 단나사	1	
W-24	GP-002047-00		Feed Guide Shaft	이송 가이드 축	2	
W-25	PSC-AC000200		Screw(M4×L10)	이송 가이드 축 쥘나사(M4×L10)	4	
W-26	GP-002048-00		Stopper Block	스토퍼 블록	1	
W-27	PSC-AC000200		Screw	스토퍼 블록 쥘나사(M4×L10)	1	
W-28	PWS-AA001000		Washer	스토퍼 블록 쥘나사 와셔	1	
W-29	CL-000005-00		Collar For Stopper Block	스토퍼 블록 카라	2	
W-30	PSC-CB000200		Screw(M4×L4)	스토퍼 블록 카라 쥘나사(M4×L4)	2	
W-31	GP-002049-00		Limit Switch Setting Plate	리미트 스위치 셋팅판	1	
W-32	PSC-AC000200		Screw(M4×L10)	리미트 스위치 셋팅판 쥘나사(M4×L10)	2	
W-33	PWS-AA001000		Washer	리미트 스위치 셋팅판 쥘나사 와셔	2	
W-34	GP-006004-00		Limit Switch	리미트 스위치	2	
W-35	PSC-AC010100		Screw(M3×L12)	리미트 스위치 쥘나사(M3×L12)	4	
W-36	GP-007346-00		Hand Switch Support Plate	핸드 스위치 지지판	1	
W-37	GP-002051-00		Feed Moving Block	이송 운동 블록	1	
W-38	BR-000004-00		Bearing	이송 운동 블록 베어링(LM6UU)	1	
W-39	PSR-AA000300		C-Ring(φ12)	이송 운동 블록 베어링 C-링(φ12, 축용)	1	
W-40	GP-002052-00		Cylinder Setting Bracket	실린더 셋팅 브라켓	1	
W-41	PSC-AC000200		Screw(M4×L10)	실린더 셋팅 브라켓 쥘나사(M4×L10)	2	
W-42	GP-005995-00		Feed Pin Moving Air Cylinder	이송핀 작동 에어 실린더	1	
W-43	PPP-AA000100		Air Cylinder Fitting	에어 실린더 피팅	1	
W-44	PN-000073-00		Feed Pin	이송핀	1	
W-45	PWS-AA001000		Washer	이송핀 와셔	1	
W-46	GP-002053-00		Spring For Feed Pin	이송핀 스프링	1	
W-47	GP-002054-00		Guide Plate For Feed Pin	이송핀 가이드판	1	
W-48	PSC-AC000200		Screw(M4×L10)	이송핀 가이드판 쥘나사(M4×L10)	2	
W-49	GP-002055-00		Cloth Feed Bar Guide(L)	천 이송바 가이드(좌)	1	
W-50	PSC-AC004100		Screw(M4×L8)	천 이송바 가이드(좌) 쥘나사(M4×L8)	1	
W-51	PSC-AC000900		Stopper Screw(M5×L15)	천 이송바 스토퍼 쥘나사(M5×L15)	1	
W-52	PSN-AA000700		Nut(M5)	천 이송바 스토퍼 쥘나사 너트(M5)	1	
W-53	GP-002056-00		Feed Base(L)	이송 베이스(우)	1	
W-54	GP-005995-00		Feed Base(L) Air Cylinder	이송 베이스(우) 에어 실린더	1	
W-55	PPP-AA000100		Air Cylinder Fitting	에어 실린더 피팅	1	
W-56	GP-001687-00		Air Cylinder Rubber Cap	에어 실린더 고무마개	1	
W-57	GP-002057-00		Cloth Feed Bar Guide(R)	천 이송바 가이드(우)	1	

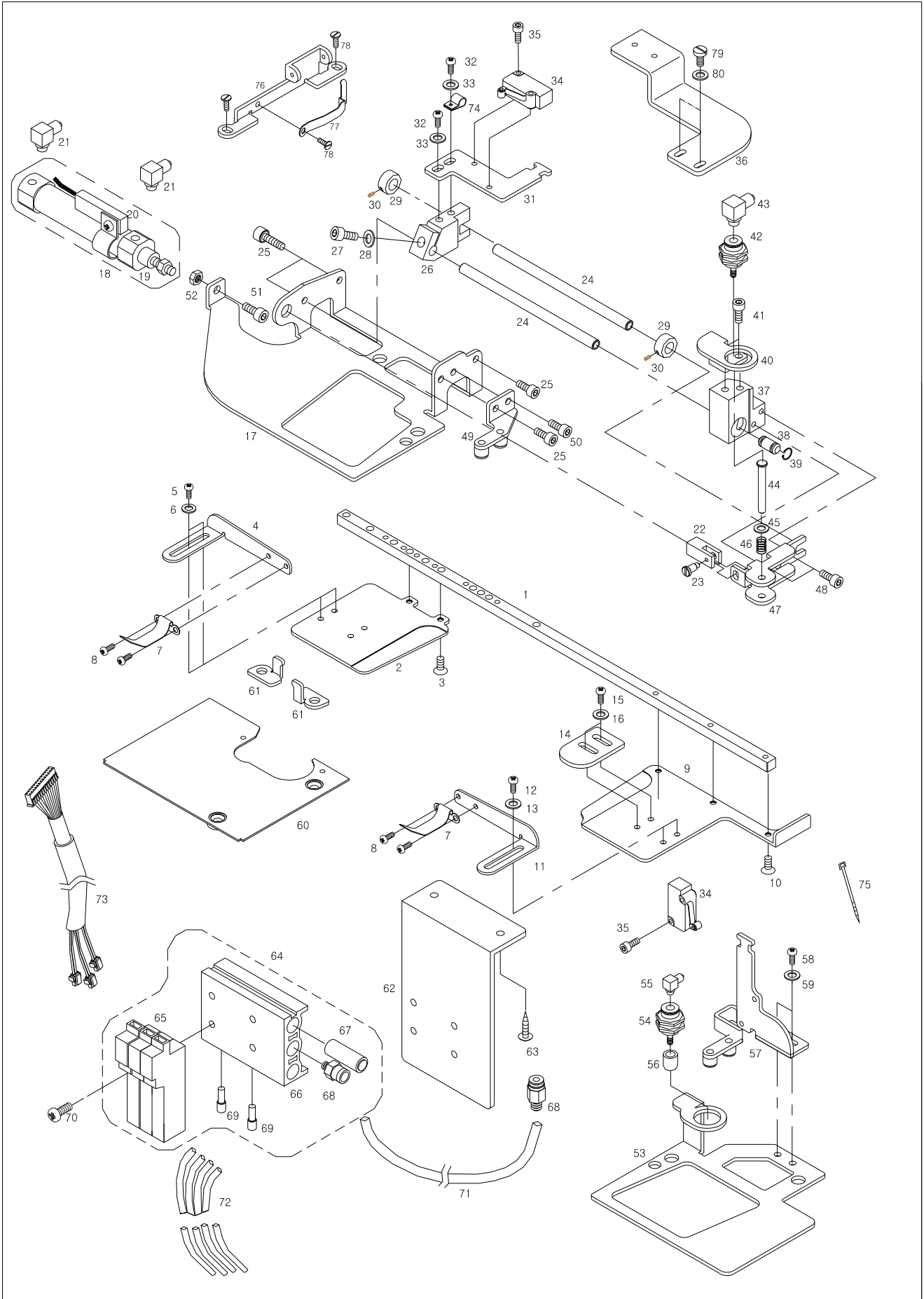



# X

## Upper Thread Nipper Mechanism

윗실잡이 관계

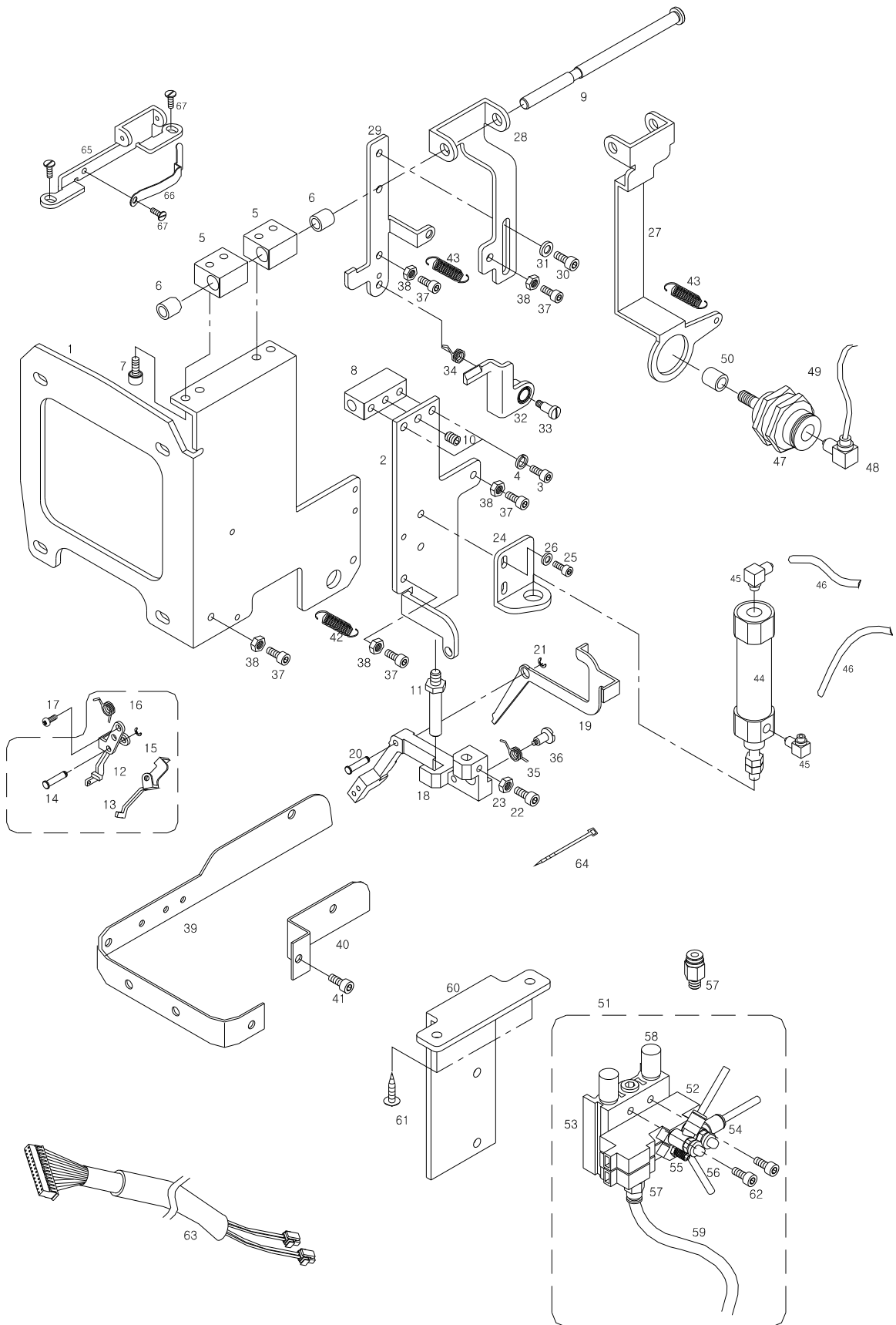

Ref. No.	Parts No.	Note	Name of Parts	품 명	Q'ty	Assembly
X-1	GP-002194-00		Bracket For Upper Thread Nipper	윗실잡이 브라켓	1	
X-2	GP-002192-00		Support For Upper Thread Nipper Cylinder	윗실잡이 실린더 지지대	1	
X-3	PSC-AC000200		Screw(M4×L10)	실린더 지지대 고정나사(M4×L10)	2	
X-4	PWS-CA000900		Spring Washer	고정나사 스프링 와셔	2	
X-5	GP-002182-00		Support A For Support Shaft	지지축 지지대A	2	
X-6	GP-002200-00		Support DU-Bushing	지지대 DU-붓싱(DU0605)	2	
X-7	PSC-AC000200		Screw(M4×L10)	지지축 지지대 고정나사(M4×L10)	4	
X-8	GP-002183-00		Support B For Support Shaft	지지축 지지대B	1	
X-9	GP-002181-00		Upper Thread Nipper Support Shaft	윗실잡이 지지 축	1	
X-10	PSC-CB000200		Screw(M4)	지지 축 찰나사(M4)	1	
X-11	GP-002180-00		Support Guide Shaft	지지대 가이드 축	1	
X-12	GP-002195-00		Thread Nipper A	실잡이 A	1	
X-13	GP-002196-00		Thread Nipper B	실잡이 B	1	
X-14	PN-000081-00		Thread Nipper Support Pin	실잡이 지지 핀	1	
X-15	PSR-AD001300		E-Ring(φ2)	지지 핀 E-링(호칭경φ2)	1	
X-16	GP-002173-00		Thread Nipper Return Spring	실잡이 복귀 스프링	1	
X-17	PSC-BA000500		Screw(M3×L6)	실잡이 고정나사(M3×L6)	2	
X-18	GP-002197-00		Support For Upper Thread Nipper	윗실잡이 지지대	1	
X-19	GP-002185-00		Lever For Thread Nipper	실잡이 레버	1	
X-20	PN-000081-00		Lever Pin	레버 핀	1	
X-21	PSR-AD001300		E-Ring(φ2)	레버 핀 E-링(호칭경φ2)	1	
X-22	PSC-AC010300		Stopper Screw(M3×L8)	실잡이 레버 멈춤나사(M3×L8)	1	
X-23	PSN-AA002400		Stopper Nut(M3)	멈춤나사 너트(M3)	1	
X-24	GP-002184-00		Cylinder Setting Bracket	실린더 셋팅 브라켓	1	
X-25	PSC-AC000200		Screw(M4×L10)	셋팅 브라켓 고정나사(M4×L10)	2	
X-26	PWS-AA001000		Washer	고정나사 와셔	2	
X-27	GP-002191-00		Support For Thread Nipper Setting Cylinder	실잡이 위치 셋팅 실린더 지지대	1	
X-28	GP-002187-00		Bracket A For Cam Lever Support	캠레버 지지 브라켓A	1	
X-29	GP-002189-00		Cam Lever Support Bracket B	캠레버 지지 브라켓B	1	
X-30	PSC-AC000200		Screw(M4×L10)	브라켓B 고정나사(M4×L10)	2	
X-31	PWS-AA001000		Washer	고정나사 와셔	2	
X-32	GP-002188-00		Cam Lever Ass'y For U-Thread Nipper	윗실잡이 캠레버(조)	1	
X-33	GP-002179-00		Stud Screw For Cam Lever	캠레버 단나사	1	
X-34	GP-002175-00		Cam Lever Return Spring	캠레버 복귀 스프링	1	
X-35	GP-002174-00		Thread Nipper Lever Return Spring	실잡이 레버 복귀 스프링	1	
X-36	GP-002178-00		Stud Screw For Thread Nipper Lever	실잡이 레버 복귀 스프링 단나사	1	
X-37	PSC-AC009400		Setting Screw(M4×L15)	셋팅 나사(M4×L15)	5	
X-38	PSN-AA002300		Nut(M4)	셋팅 나사 너트(M4)	5	
X-39	GP-002193-00		Cover For Needle Bar Timing Belt(C)	바늘대 타이밍 폴리 커버(C)	1	
X-40	GP-002190-00		Cover(D) For Needle Bar Timing Belt	바늘대 타이밍 폴리 커버(D)	1	
X-41	PSC-AC000200		Screw(M4×L10)	바늘대 타이밍 폴리 커버(D) 고정나사(M4×L10)	1	
X-42	GP-002177-00		Spring For Cylinder Support	실린더 지지대 스프링	1	
X-43	GP-002176-00		Spring For Cam Lever Support Bracket B	캠레버 지지 브라켓 B 스프링	2	
X-44	GP-002198-00		Thread Nipper Air Cylinder	실잡이 에어 실린더	1	
X-45	PPP-AA000100		Air Cylinder Fitting	에어 실린더 피팅	2	
X-46	PPP-AD000100		Air Tube(φ4)	에어 호스(φ4)	-	
X-47	GP-002199-00		Thread Nipper Setting Air Cylinder	실잡이 위치 셋팅 에어 실린더	1	
X-48	PPP-AA000100		Air Cylinder Fitting	에어 실린더 피팅	1	
X-49	PPP-AD000100		Air Tube(φ4)	에어 호스(φ4)	-	
X-50	GP-001687-00		Air Cylinder Rub Cap	에어 실린더 고무마개	1	
X-51	AS-000351-00		Air Solenoid Valve ASM (E)	에어 솔레노이드 밸브(조)(E)	1Set	
X-52	PPP-BA000400		Solenoid Valve	솔레노이드 밸브	2	
X-53	PPP-BB000100		Manifold Block	매니폴드 블록	1	
X-54	PPP-AB001100		Speed Controller	스피드 컨트롤러	2	
X-55	PPP-AA000200		Hose Nipple	호스 니플	1	
X-56	DSC-AA002100		Flug	플러그	1	
X-57	PPP-AA002800		Half Union	하프 유니온	2	

# X

## Upper Thread Nipper Mechanism

윗실잡이 관계

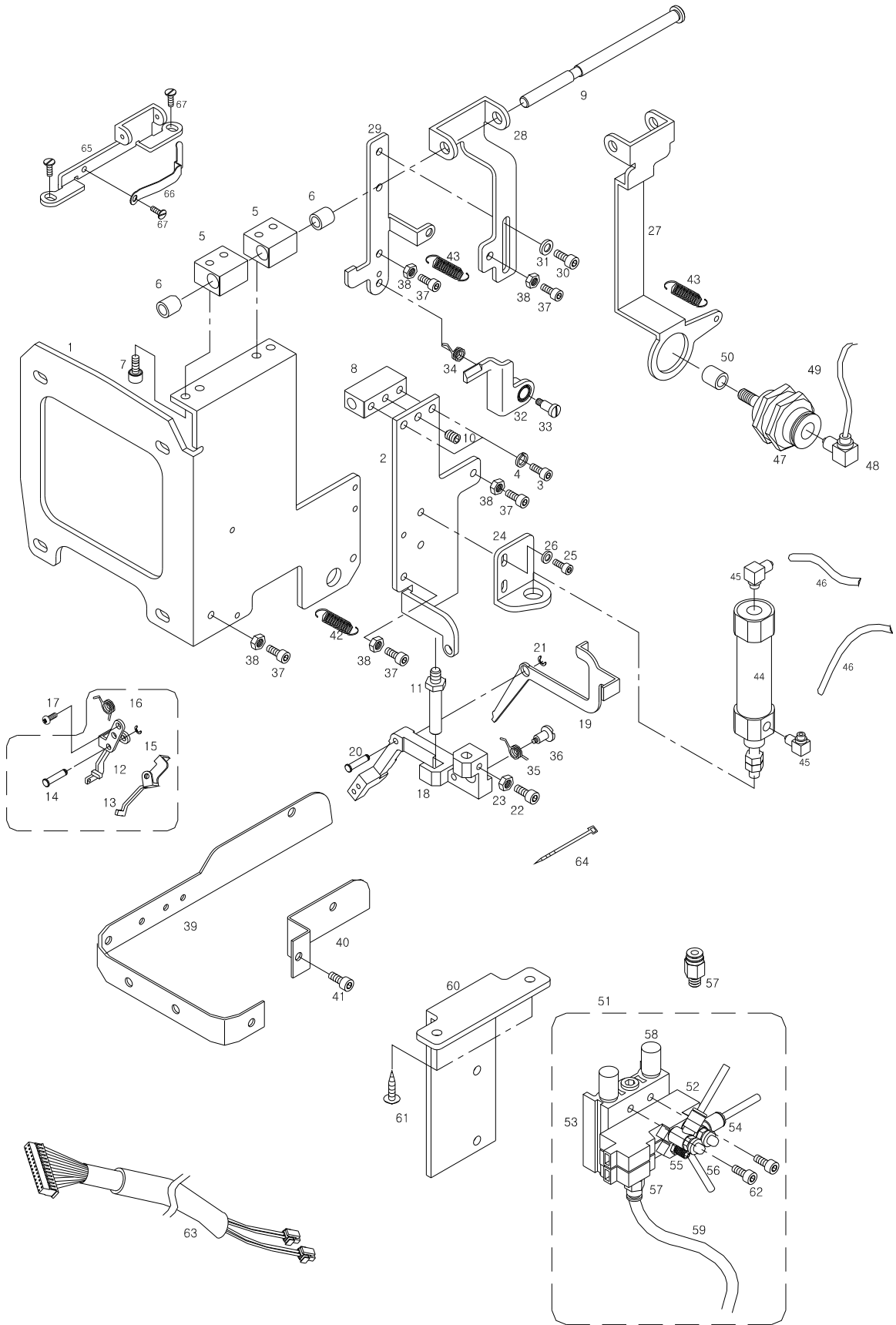





# Gauge

## 게이지

### 1.Clamp 클램프

- 01			
10~18mm	18~22mm	22~26mm	26~30mm
L : GP-002210-00	L : GP-002212-00	L : GP-002214-00	L : GP-002216-00
R : GP-002211-00	R : GP-002213-00	R : GP-002215-00	R : GP-002217-00

10~18mm	10~18mm
L : CGA-BL000100	L : GP-002220-00
R : CGA-BL000200	R : GP-002221-00

- 02			
A (14~18mm)	B (18~20mm)	C (22~26mm)	D (26~30mm)
L : GP-002244-00	L : GP-002246-00	L : GP-001694-00	L : GP-002248-00
R : GP-002245-00	R : GP-002247-00	R : GP-001695-00	R : GP-002249-00

E (28~32mm)	F (32~36mm)	G (36~40mm)
L : GP-002250-00	L : GP-002252-00	L : GP-002254-00
R : GP-002251-00	R : GP-002253-00	R : GP-002255-00

Circular Hole	
Ø5	Ø7
L : GP-007887-00	L : GP-011923-00
R : GP-007889-00	R : GP-011924-00

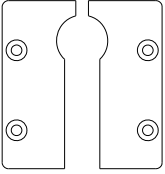
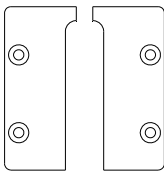

## 2. Needle Plate 침판

- 01	38mm	38mm
		
L : CGA-GA000300	L : GP-002228-00	
R : CGA-GA000400	R : GP-002229-00	

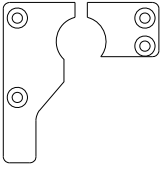
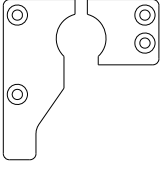
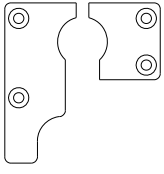
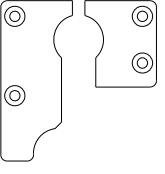
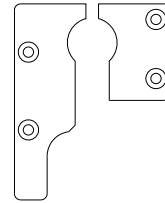
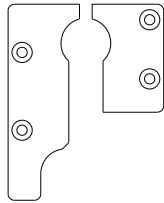
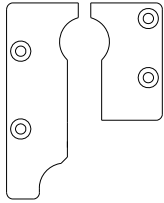
- 02	A (14~18mm)	Ø7	Ø7	Ø7
				
L : GP-002232-02	L : GP-002234-02	L : GP-001690-03	L : GP-002236-02	
R : GP-002233-02	R : GP-002235-02	R : GP-001689-02	R : GP-002237-02	
	Ø5	Ø7	Ø7	
				
L : GP-002238-02	L : GP-002240-02	L : GP-002242-02		
R : GP-002239-02	R : GP-002241-02	R : GP-002243-02		

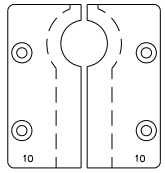
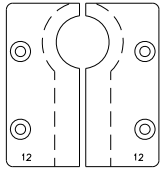
Circular Hole	Ø5	Ø7
		
L : GP-007890-00	L : GP-011921-00	
R : GP-007892-00	R : GP-011922-00	



# Gauge

## 게이지

### 3. Hammer 해머

- 01	10mm	12mm	14mm	16mm	
	GP-002268-01	GP-002269-01	GP-002270-01	GP-002271-01	
	18mm	20mm	22mm	24mm	
	GP-002272-01	CGA-GN000200	GP-002273-01	GP-002274-01	
	26mm	28mm	30mm	32mm	
	CGA-GN000100	GP-002275-01	GP-002276-01	GP-002277-01	
	34mm	36mm	38mm		
	GP-002278-01	GP-002279-01	CGA-GN000300		
- 02	S 10mm	S 12mm	S 14mm	S 16mm	
	GP-002281-01	GP-002282-01	GP-002283-01	GP-002284-01	
	S 18mm	S 20mm	S 22mm	S 24mm	
	GP-002285-01	GP-001701-01	GP-002286-01	GP-001702-01	
	S 26mm	S 28mm	30mm	32mm	
	GP-002287-01	GP-002288-01	GP-002276-01	GP-002277-01	
	34mm	36mm	38mm		
	GP-002278-01	GP-002279-01	CGA-GN000300		
Circular Hole	Ø5		Ø7		
	GP-007893-00		GP-011919-00		

### 4. Cutter 커터

GP-002258-00	CGA-GF000100	GP-002259-00	GP-002260-00	GP-002261-00	GP-002262-00

#### Circular Hole

Ø2	Ø3	Ø4	Ø5
R : GP-011907-00	R : GP-007895-00	R : GP-007896-00	R : GP-011920-00



# Index

Parts No.	Name of Parts	Page	Ref.No.	Parts No.	Name of Parts	Page	Ref.No.	Parts No.	Name of Parts	Page	Ref.No.
01-000A-BH6U	Control Box Ass'y	73	T-1	11-1000-PT11	One Step Stroke	71	S-17	CA-000725	Cable	25	F1-51
01-001S-NET1	Screw(M3×L6)	73	T-36	12-011A-PT11	Foot Switch Ass'y	71	S-15	CA-000726	Cable	71	S-26
01-001S-NET1	Screw(M3×L6)	73	T-52	12-115C-SW70	Fuse(15A)	69	R-14	CA-000727	Cable	65	P-36
01-001S-NET1	Screw(M3×L6)	75	T-62	15015SC-7113	Screw(M4×L10)	33	I-34	CA-000730	Cable	11	A-131
01-002M-AU12	Screw(M4×L35)	73	T-17	15-026M-1000	Cable Tie	77	U-10	CA-000730	Cable	35	I-80
01-003S-2070	Screw(M4×L16)	75	T-56	16-016A-SC53	IC AT24C04-10PU-2.7	75	T-85	CA-002911	Jumper Cap(Red)	75	T-88
01-005A-BT01	Step Board Fan	73	T-46	16-103A-SC53	IC-GAL22V10D-25LPN	75	T-86	CA-005121	X-Feed Sensor	33	I-28
01-017C-DU33	Screw(M4×L25)	73	T-47	40-224A-300G	Thread Tension Adjusting Shaft	57	N-2	CA-005122	Y-Feed Sensor	35	I-70
01-035P-7400	Pin	11	A-129	49-018A-12HA	Felt	63	O-60	CA-005123	Needle Bar Rocking Sensor	31	H-30
01-060M-300G	Warning Sign Sticker	11	A-97	91-001C-BT10	Urethane Washer	75	T-76	CA-005124	Lower Shaft Sensor(Ass'y)	21	D-24
01-100B-BH6U	BH6U SMPS Bracket(set)	75	T-81	91-001C-PT10	Table Washer	75	T-77	CAB-AA0014	Arm	9	A-1
01-200B-BH6U	BH6U Digital Bracket(set)	75	T-82	91-002S-1067	Screw Nail	79	V-35	CAB-AB0011	Bed	9	A-2
01-300B-BH63	Step B/D Bracket(set)	75	T-87	91-020A-300G	Pin Set	69	R-18	CAB-BA0001	Base	9	A-3
02-002A-BHUP	LCD	77	U-5	AAR-PS0009	Air Solenoid Valve ASM (A)	65	P-12	CAC-JB0001	Oiler	69	R-5
02-004B-BD01	IC 27C512	77	U-15	AAR-PS0010	Air Solenoid Valve ASM (B)	65	P-18	CAC-JB0002	Bottle Of Oil	69	R-19
03-001A-ZIZA	IC AT28C256-15PUEEPROM	75	T-83	AAR-PS0011	Filter Regulator ASM	65	P-3	CAC-MA0001	Head Cover	69	R-17
03-002A-BH30	IC AM27C010(M27C1001)	75	T-84	ACT-PS0001	Cutter Pipe(Ass'y)	43	K-54	CAC-MH0001	Accessory Bag	69	R-26
03071SC-A001	Screw(M3×L15)	79	V-6	ALP-PS0001	Looper Link Ass'y	55	M-1	CAR-BB0003	Manifold Bracket	65	P-1
04-001C-SE50	Screw(ST5×L16)	75	T-72	ALP-PS0002	Cam Lever Ass'y	55	M-13	CCP-BB0013	Spring Hook For Presser Plate(L)	37	J-31
04-003B-PT10	Card Volume	77	U-16	ALT-PS0001	LTT Link Lever	25	F1-38	CCP-BB0014	Spring Hook For Presser Plate(R)	37	J-32
05014SC-4113	Solenoid Valve Screw(M4×L25)	87	X-62	AMB-PS0017	Lower Thread Guide Pipe A	57	N-42	CCP-BF0002	Shaft Holder For Clamp Lever Shaft	39	J1-55
06-002B-BH30	Header 20P	77	U-17	AMB-PS0018	Gimp Thread Guide Pipe B Ass'y	59	N-65	CCP-BF0002	Shaft Holder For Clamp Lever Shaft(R)	41	J2-55
07-004S-SM5S	Screw Ass'y For *A*Foot Switch Cover(M4×L8)	71	S-22	AMB-PS0019	Gimp Thread Guide Pipe A Ass'y	59	N-63	CCP-BJ0017	Cloth Guide(L)	39	J1-50
07-004S-SM5S	Screw(M4×L10)	75	T-63	ANB-PS0001	Needle Bar Driving Gear Ass'y	17	C-44	CCP-BJ0017	Cloth Guide (R)	41	J2-50
08-015C-3701	Clamp Cable	71	S-18	ANR-PS0001	Idler Bracket(D) Ass'y	31	H-12	CCP-BJ0018	Cloth Guide(R)	39	J1-45
09-012S-CE53	Caution Sticker	75	T-71	ANR-PS0002	Idler Bracket(U) Ass'y	31	H-15	CCP-BJ0018	Cloth Guide(R)	41	J2-45
09018SC-8118	Screw(M4×L6)	27	F2-14	ANR-PS0003	Needle Bar Rocking Pulley Ass'y	31	H-6	CCP-BJ0019	Cover For Slide Block	39	J1-53
09-031S-3701	Screw(M4×L8)	71	S-19	AS-000267	Needle Bar Rocking Shaft Ass'y	31	H-18	CCP-BJ0019	Cover For Slide Block	41	J2-53
10-001M-5030	Screw(M6×L50)	75	T-73	AS-000305	LTT Link Lever(Ass'y)	27	F2-19	CCP-BJ0020	Work clamp Plate(L)	39	J1-70
10-002S-SW66	Screw(M3×L8)	73	T-27	AS-000351	Air Solenoid Valve ASM (E)	85	X-51	CCP-BJ0021	Work Clamp Plate(R)	39	J1-64
10-002S-SW66	Screw(M3×L8)	73	T-29	AS-000375	Roller Cam Lever(Ass'y)	55	M-27	CCP-BL0012	Clamp Arm(L)	39	J1-67
10-002S-SW66	Screw(M3×L8)	73	T-35	AS-000377	Lower Thread Tension Adjusting(Ass'y)	49	L-64	CCP-BL0013	Clamp Arm(R)	39	J1-61
10-002S-SW66	Screw(M3×L8)	73	T-43	AS-000382	Air Pressure Ass'y	65	P-37	CCP-BM0003	Clamp Cylinder Rod	37	J-28
10-002S-SW66	Screw(M3×L8)	73	T-44	AS-001290	Air Solenoid Valve ASM.	79	V-29	CCP-CD0006	Slide Block For Cloth Opening	39	J1-52
10-002S-SW66	Screw(M3×L8)	73	T-45	AS-001521	Air Pressure Ass'y	65	P-38	CCP-CD0006	Slide Block For Cloth Opening	41	J2-52
10-002S-SW66	Screw(M3×L8)	73	T-51	AS-001614	Air Solenoid Valve ASM(D)	83	W-64	CCP-CM0016	Clamp Driving Lever	37	J-34
10-002S-SW66	Screw(M3×L8)	75	T-61	AS-001622	Cloth Feed Air Cylinder Ass'y	81	W-18	CCP-CM0017	Clamp Lever B	37	J-37
10-003M-PT01	Screw(M4×L8)	75	T-65	AS-005459	Needle Guide Support Ass'y	49	L-63	CCP-CM0018	Clamp Lever(L)	39	J1-65
10-003M-PT10	Screw(M4×L10)	75	T-57	AS-007503	Lower Thread Trim Arm Ass'y	25	F1-50	CCP-CM0018	Clamp Lever(L)	41	J2-70
10-003S-SW66	Spring Washer(M6)	75	T-74	AS-007506	Moving Mes C(L, R)Ass'y	27	F2-25	CCP-CM0019	Clamp Lever(R)	39	J1-59
10-004M-SW68	Screw(M3×L5)	73	T-12	AS-007507	Bracket for Upper Thread Trimmer Ass'y	53	L3-93	CCP-CM0019	Clamp Lever(R)	41	J2-58
10-004M-SW68	Screw(M3×L5)	73	T-14	AST-PS0001	Gas Spring Ass'y For Head	11	A-70	CCP-KC0006	Shaft For Clamp Driving Lever	37	J-36
10-004M-SW68	Screw(M3×L5)	73	T-19	ATA-PS0014	Thread Tension Adjusting Ass'y	57	N-1	CCP-KC0007	Cylinder Support Shaft	37	J-26
10-004M-SW68	Screw(M3×L5)	73	T-24	ATA-PS0015	Sub Thread Tension Adjusting Ass'y	57	N-16	CCP-KC0008	Shaft For Clamp Lever	39	J1-57
10-004S-SW66	Washer(M6)	75	T-75	ATH-PS0002	Thread Take-up Lever (Ass'y)	19	C-60	CCP-KC0008	Shaft For Clamp Lever(R)	41	J2-56
10-012M-PT10	Main Board Stud	75	T-55	AYF-PS0004	Y-Feed Shaft Ass'y	33	I-57	CCP-LB0001	Cover Plate(L)	39	J1-49
10-016S-CPT1	Screw(M4×L12)	73	T-4	BD-000203	DDC Board	73	T-28	CCP-LB0002	Cover Plate(R)	39	J1-44
10-016S-CPT1	Screw(M4×L12)	73	T-6	BD-000206	Main Board	75	T-53	CCT-BB0003	Cutter Bracket	43	K-30
10-016S-CPT1	Screw(M4×L12)	73	T-8	BD-000314	Step Board	73	T-37	CCT-BB0004	Cutter Sensor Bracket	43	K-46
10-016S-CPT1	Screw(M4×L12)	73	T-10	BD-000317	O/P Board	77	U-3	CCT-BF0002	Cutter Holder	43	K-33
10-020M-SW66	Screw(M3×L12)	73	T-22	BD-000325	Digital Board	73	T-30	CCT-BJ0003	Cutter Sensor Plate	43	K-41
10-024M-SW66	Screw(ST3×L8)	77	U-4	BD-000326	Backplane Board	73	T-21	CCT-BJ0004	Cutter Bracket Guide	43	K-52
10-028S-SC53	Screw Ass'y For *B*Foot Switch Cover(M4×L8)	71	S-23	BR-000004	Bearing	81	W-38	CCT-BJ0005	Cutter Stopper Plate	43	K-35
10-043R-9577	Fixing Bolt Rubber Washer (Option)	11	A-117	BR-000082	Bearing	19	C-69	CCT-BJ0006	Cutter Adjusting Plate	43	K-49
10-073S-3701	Screw(M3×L10)	73	T-33	CA-000243	Pneumatic I/O Cable	83	W-73	CCT-BL0001	Hammer Presser	43	K-2
10-073S-3701	Screw(M3×L10)	73	T-50	CA-000342	SMPS Connecting Cable1	75	T-78	CCT-BM0001	Cutter Cylinder Rod	43	K-21
10-073S-3701	Screw(M3×L10)	75	T-60	CA-000343	SMPS Connecting Cable2	75	T-79	CCT-CA0001	Link A	43	K-11
11-001A-PT10	Base Foot Switch	71	S-16	CA-000708	Operation Cable	77	U-9	CCT-CA0002	Link C	43	K-14
11-001S-PT10	Ending Bushing	71	S-20	CA-000710	Cable	65	P-39	CCT-CM0001	Cutter Lever	43	K-1
11-002M-PT10	Sponge	71	S-24	CA-000721	Cable	65	P-40	CCT-FZ0001	Cutter Lever Cover	43	K-56
11-002S-5050	Screw(ST3×L8)	77	U-8	CA-000722	Pneumatic I/O Cable	65	P-34	CCT-KC0001	Cutter Lever Shaft	43	K-7
11-003A-PT10	Cover Foot Switch	71	S-21	CA-000723	Cutter Sensor(Ass'y)	43	K-44	CCT-KC0002	Cutter Cylinder Support Shaft	43	K-24

# Index

Parts No.	Name of Parts	Page	Ref.No.	Parts No.	Name of Parts	Page	Ref.No.	Parts No.	Name of Parts	Page	Ref.No.
CCT-KC0003	Cylinder Rod Shaft	43	K-22	CLP-BF0001	Clamp For Looper Link	47	L-11	CLT-CM0002	Low Thread Trim Arm	25	F1-20
CCT-KC0004	Link Shaft B	43	K-15	CLP-BJ0001	LS-Slide Guide	47	L-9	CLT-LA0001	Lower Thread Trim Cover Plate	25	F1-42
CCT-KC0005	Link Shaft A	43	K-17	CLP-BJ0002	Looper Driving Plate	55	M-9	CLT-NA0001	Lower Thread Trim Moving Mes	25	F1-25
CCT-KF0001	Link Shaft C	43	K-12	CLP-BJ0003	Support Plate For Lower Thread	47	L-52	CLT-NB0001	Lower Thread Trim Fixed Mes	25	F1-12
CGA-BL0001	Clamp (L)	39	J1-69	CLP-BJ0004	Presser Plate For Lower Thread	47	L-53	CMB-BB0036	Safety Plate Guide	9	A-15
CGA-BL0002	Clamp (R)	39	J1-63	CLP-BJ0005	Plate For Lower Thread Support Spring	47	L-50	CMB-BB0037	Holder For Safety Plate Cylinder	9	A-11
CGA-GA0003	Needle Plate(L)	39	J1-51	CLP-BJ0006	Spring Guide For Lower Thread	47	L-46	CMB-BG0002	Lower Thread Guide Pipe Holder	57	N-47
CGA-GA0004	Needle Plate(R)	39	J1-47	CLP-BJ0007	Plate For Thread Support	47	L-44	CMB-BJ0020	Safety Plate	9	A-16
CGA-GF0001	Cutter-38mm	43	K-40	CLP-BJ0008	Tension Release Lever Plate	51	L1-79	CMB-BJ0021	Cover For Safety Plate Guide	9	A-13
CGA-GN0001	Hammer-26mm	43	K-28	CLP-BJ0009	Tension Release Plate	51	L1-76	CMB-BQ0001	Looper Thread Guide Pipe	47	L-42
CGA-GN0002	Hammer-20mm	69	R-22	CLP-BJ0009	Tension Release Plate	53	L2-83	CMB-BQ0003	Lower Thread Guide Pipe B	57	N-46
CGA-GN0003	Hammer-38mm	69	R-23	CLP-BJ0010	Looper Tension Release Plate	51	L1-82	CMB-FC0018	Gasket For Top Cover	9	A-20
CHS-BJ0001	Switch Setting Plate	71	S-6	CLP-BJ0010	Looper Tension Release Plate	53	L2-86	CMB-FC0019	Gasket For Face Plate	9	A-8
CHS-CM0001	Hand Switch Lever(L)	71	S-8	CLP-CA0001	Link For Spreader Cam	47	L-18	CMB-HK0023	Arm Thread Guide	57	N-33
CHS-CM0002	Hand Switch Lever(R)	71	S-9	CLP-CA0002	Drive Link For Looper	47	L-13	CMB-HK0024	Upper Thread Guide C	57	N-27
CHS-LA0001	Hand Switch Cover	71	S-12	CLP-CL0001	Roller Screw For Spreader Cam Link	47	L-20	CMB-HK0025	Upper Thread Guide D	57	N-29
CL-000005	Collar For Stopper Block	81	W-29	CLP-CL0002	Roller For Looper Link Stud	47	L-15	CMB-HK0026	Upper Thread Guide B	57	N-25
CL-000033	Collar For Gimp Thread Tension Release Plate	59	N-75	CLP-CL0003	Looper Cam Roller	55	M-2	CMB-HK0027	Upper Thread Guide	57	N-31
CL-000118	Collar	41	J2-97	CLP-CL0004	Spreader Cam Lever	55	M-25	CMB-HK0028	Gimp Thread Guide A	57	N-49
CLB-BB0005	Oil Tank Bracket	61	O-16	CLP-CL0005	Collar For Thread Support Plate	47	L-45	CMB-HK0029	Gimp Thread Guide B	59	N-67
CLB-BG0024	Support For Oil Felt Lower Shaft	61	O-18	CLP-CM0001	Spreader Driving Lever	55	M-20	CMB-HK0030	Lower Thread Guide	57	N-44
CLB-BG0028	Felt Support	61	O-26	CLP-CM0003	Cam Lever	55	M-14	CMB-HK0033	Pin For Upper Thread Guide	57	N-21
CLB-BG0029	Wick Support For Looper Link	61	O-24	CLP-CM0004	Spreader Stopper(L)	47	L-33	CMB-HK0034	Upper Thread Guide A	57	N-23
CLB-BG0030	Support For Oil Felt Upper Shaft	61	O-1	CLP-CM0005	Spreader Stopper(R)	47	L-34	CMB-HK0035	Sub Upper Thread Adjusting Guide(U)	59	N-84
CLB-BH0010	Oil Hose Holder	61	O-41	CLP-CM0006	Bracket For Upper Thread Trimmer	51	L1-62	CMB-HK0036	Sub Upper Thread Adjusting Guide(L)	59	N-85
CLB-BH0011	Wick Holder A	61	O-35	CLP-CM0007	Tension Release Claw	51	L1-91	CMB-LA0035	Motor Cover	9	A-23
CLB-FA0001	Oil Window Rubber Ring	61	O-13	CLP-CM0008	Tension Release Lever Ass'y	51	L1-75	CMB-LA0036	Top Cover	9	A-18
CLB-JB0003	Oil Tank Ass'y	61	O-14	CLP-CM0008	Tension Release Lever Ass'y	53	L2-82	CMB-LA0037	Face Plate	9	A-6
CLB-JD0003	Oil Wick	61	O-4	CLP-DZ0001	Spreader Driving Cam	47	L-26	CMB-LA0038	Cover For Emergency Stop S/W	9	A-30
CLB-JD0003	Wick For Looper Base	61	O-33	CLP-GA0001	Throat Plate	51	L1-72	CMB-LA0039	Cover For Needle Bar Timing Belt	9	A-36
CLB-JD0003	Oil Wick	61	O-37	CLP-HG0001	Needle Guide	47	L-36	CMB-LA0067	Finger Guard	9	A-39
CLB-JD0003	Oil Wick	61	O-38	CLP-HK0001	Gimp Guide	51	L1-69	CMB-LA0068	Cover For Gimp Thread Take-Up Lever Ass'y	9	A-26
CLB-JD0003	Oil Wick	61	O-43	CLP-HM0001	Shaft For Spring Guide	47	L-49	CMB-LB0035	Bed Cover(R)	9	A-21
CLB-JD0003	Oil Wick	61	O-44	CLP-KC0001	Looper Link Support Shaft	55	M-5	CMB-LB0045	Cover For Zigzag Adjusting Lever	9	A-32
CLB-JD0003	Oil Wick	61	O-49	CLP-KC0001	Cam Lever Support Shaft	55	M-16	CMB-LD0002	Caution Sticker	13	A-134
CLB-JD0003	Oil Wick	61	O-50	CLP-KC0002	Holder Support Shaft	47	L-24	CMB-LD0017	Head Safety Warning Sticker	11	A-96
CLB-JG0003	Hose A	61	O-7	CLP-KC0003	Tension Release Lever Shaft	51	L1-86	CNB-BB0001	Support A For Needle Bar Driven Pulley	17	C-25
CLB-JG0003	Hose B	61	O-8	CLP-KC0003	Tension Release Lever Shaft	53	L2-90	CNB-BB0002	Support B For Needle Bar Driven Pulley	17	C-23
CLB-JG0003	Hose	61	O-39	CLP-KF0001	Looper Driving Shaft	47	L-5	CNB-BF0005	Holder For Needle Bar Bush(U)	17	C-54
CLB-JG0003	Hose	61	O-40	CLP-KZ0001	Spreader Link Shaft Ass'y	47	L-8	CNB-BF0006	Clamp For Needle Bar	17	C-32
CLB-JG0003	Hose	61	O-45	CLS-BB0001	Idler(Ass'y)	21	D-15	CNB-BF0006	Zigzag Clamp	29	G-23
CLB-JG0003	Hose	61	O-54	CLS-BJ0001	Lower Shaft Sensor Plate	21	D-4	CNB-BJ0004	Support Plate For Needle Bar Guide	17	C-16
CLB-JG0007	Oil Tube For Looper Base	61	O-34	CLS-BJ0003	Cover For Lower Shaft Cam	61	O-22	CNB-BN0001	Ring For Needle Bar Bush(U)	17	C-51
CLB-JJ0001	Oil Winder	61	O-11	CLS-CG0001	Idler For Upper Shaft Timing Belt	21	D-20	CNB-CA0001	Needle Bar Feed Link	17	C-34
CLB-JL0008	Rubber Cap	63	O-61	CLS-DG0001	Lower Shaft Cam	21	D-10	CNB-CA0002	Zigzag Feed Link	17	C-19
CLB-JL0025	Needle Bar Felt (U)	17	C-49	CLS-KF0002	Lower Shaft	21	D-1	CNB-CA0003	Needle Bar Yoke Link	17	C-35
CLB-JL0026	Needle Bar Felt (L)	17	C-27	CLS-LA0001	Cover For Lower Shaft Pulley	21	D-9	CNB-CC0002	Needle Bar Driving Rod Ass'y	17	C-43
CLB-JL0028	Oil Felt For Upper Shaft	61	O-2	CLT-BB0001	Cylinder Support Plate For LTT	25	F1-1	CNB-CM0001	Needle Bar Driving Lever	17	C-36
CLB-JL0030	Oil Felt For Cutter Lever Shaft	61	O-51	CLT-BB0002	Fixed Mes Bracket	25	F1-4	CNB-CN0001	Needle Bar Guide	17	C-14
CLB-JL0031	Oil Felt For Lower Felt	61	O-20	CLT-BB0003	Fixed Mes Setting Bracket	25	F1-6	CNB-CR0001	Needle Bar Block	17	C-10
CLB-JL0036	Oil Felt For Looper Base	61	O-30	CLT-BB0005	Cylinder Claw For LTT	25	F1-3	CNB-HK0007	Needle Bar Thread Guide	17	C-2
CLB-JL0037	Oil Felt For Felt Support	61	O-28	CLT-BG0001	Return Spring Holder For LTT(A)	25	F1-35	CNB-HK0008	Thread Guide Plate A	17	C-6
CLB-JL0038	Oil Felt For Looper Driving Shaft	19	C-74	CLT-BJ0001	Opener	25	F1-23	CNB-HK0010	Thread Guide Plate B	17	C-7
CLB-JL0038	Oil Felt For Looper Driving Shaft	61	O-29	CLT-BJ0002	Opener Spring Plate	25	F1-21	CNB-KA0006	Needle Bar	17	C-1
CLB-JL0039	Oil Felt For Arm	61	O-6	CLT-BJ0003	Lower Thread Guide Plate	25	F1-8	CNB-KC0002	Shaft For Needle Bar Driving Lever	17	C-37
CLB-JN0001	Oil Gauge	61	O-12	CLT-BJ0004	Spring Plate For Fixed Mes(U)	25	F1-10	CNB-KH0001	Shaft For Needle Bar Driving Gear	17	C-45
CLP-BA0001	Base For Spreader Link	47	L-16	CLT-BJ0005	Spring Plate For Fixed Mes(D)	25	F1-11	CNB-LA0001	Needle Bar Guard	17	C-56
CLP-BA0002	Looper Base	47	L-1	CLT-BJ0006	Lower Thread Retainer	25	F1-27	CNR-BA0001	Needle Bar Rocking Motor Base	31	H-1
CLP-BB0001	Ls Holder Bracket	47	L-27	CLT-BJ0007	Thread Nipper(U)	25	F1-13	CNR-BB0001	Sensor Bracket	31	H-31
CLP-BB0002	Needle Guide Support	47	L-38	CLT-BJ0008	Thread Nipper(M)	25	F1-14	CNR-CG0001	Needle Bar Rocking Idler Pulley	31	H-8
CLP-BB0003	Moving Mes Bracket	51	L1-65	CLT-BJ0009	Thread Nipper(L)	25	F1-16	CNR-KC0001	Needle Bar Rocking Shaft	31	H-19
CLP-BB0004	Tension Release Claw Support	51	L1-89	CLT-CM0001	Lower Thread Trim Lever Arm	25	F1-32	CPR-BD0002	Cylinder For Cloth Opening	37	J-5

# Index

Parts No.	Name of Parts	Page	Ref.No.	Parts No.	Name of Parts	Page	Ref.No.	Parts No.	Name of Parts	Page	Ref.No.
CPR-BJ0010	Cover For Presser Plate	37	J-21	CXF-LB0001	Feed Base Cover(L)	33	I-2	DPK-CB0018	Rubber Cap E	11	A-111
CPR-BJ0011	Guide Plate A	37	J-39	CXF-LB0002	Feed Base Cover(R)	33	I-3	DPL-BC0003	Pulley For Upper Shaft	15	B-8
CPR-BJ0012	Guide Plate B	37	J-40	CYF-BB0015	Y-Motor Base	33	I-31	DPL-BC0004	Pulley For Lower Shaft	21	D-7
CPR-BJ0013	Stopper Plate For Cylinder	37	J-13	CYF-BB0016	Y-Feed Pulley Support	33	I-46	DPL-BC0005	Needle Bar Driven Pulley	17	C-22
CPR-BJ0014	Stopper For Cover Plate	37	J-19	CYF-BB0017	Y-Guide Shaft Holder	33	I-54	DPL-BC0006	Needle Bar Rotation Pulley (D)	31	H-20
CPR-CA0012	Link A For Cloth Opening Ass'y	37	J-1	CYF-BF0004	Y-Driving Shaft Holder	35	I-60	DPL-BC0007	Needle Bar Rotation Pulley (U)	31	H-22
CPR-CA0013	Link B For Cloth Opening Ass'y	37	J-2	CYF-BJ0028	Liner Bush Stopper	33	I-25	DPL-BC0009	Looper Base Rotation Pulley	47	L-3
CPR-KC0009	Cylinder Shaft Ass'y	37	J-9	CYF-BJ0029	Y-Feed Sensor Bracket	35	I-71	DPL-BF0001	Y-Feed Timing Pulley	33	I-43
CST-BA0001	Oil Support	11	A-92	CYF-BJ0030	Y-Feed Sensor Plate	35	I-63	DPN-AA0032	Shaft A For Head Support Lever Ass'y	11	A-81
CST-BB0018	Bracket For Gas Spring Fixing	11	A-74	CYF-BJ0031	Y-Timing Belt Spacer	35	I-62	DPN-AA0033	Pin For Needle Bar Guide	17	C-11
CST-BB0021	Bed Base Bracket	9	A-44	CYF-BR0001	Y-Timing Belt Holder Plate	35	I-64	DPN-AA0046	Upper Thread Tension Release Pin	57	N-9
CST-CM0001	Head Support Lever Ass'y	11	A-80	CYF-KC0010	Y-Timing Pulley Shaft A	33	I-40	DPN-AA0048	Guide Pin	47	L-43
CST-CM0001	Head Support Lever Ass'y	11	A-80	CYF-KC0011	Y-Timing Pulley Shaft B	33	I-49	DPN-AD0026	Bed Hinge Shaft	11	A-78
CST-FB0004	Fixed Bolt Support Rubber	9	A-47	CYF-KC0013	Y-Guide Shaft	33	I-52	DPN-AD0034	Shaft B For Head Support Lever Ass'y	11	A-83
CST-FB0005	Oiler Support Rubber Cap	11	A-121	CZG-BJ0006	Plate For Needle Bar Adjusting Ass'y	29	G-15	DPN-AD0035	Shaft A For Gas Spring Support	11	A-71
CST-FB0006	Rubber Washer For Cap Screw	11	A-90	CZG-CB0002	Crank For Zigzag	29	G-9	DPN-AD0036	Shaft A For Gas Spring Support	11	A-72
CST-FD0010	Rubber For Support Bed	11	A-61	CZG-CJ0001	Eccentric Pin For Zigzag	29	G-14	DPN-AD0037	Pin For Needle Bar Driving Lever	17	C-41
CST-JA0009	Bed Base	9	A-43	CZG-CM0005	Zigzag Lever	29	G-22	DPN-AD0041	Knuckle Pin	23	E-14
CST-JB0001	Oiler	11	A-91	CZG-CM0006	Zigzag Fork	29	G-1	DPN-AD0041	Pin For Cylinder Rod	37	J-29
CST-LB0003	Front Cover For Bed Base	9	A-57	CZG-CR0001	Zigzag Connecting Bar	29	G-5-1	DPN-AD0041	Cylinder Knuckle Pin	41	J2-94
CST-LG0014	Table(S)	67	Q-2	CZG-KZ0001	Rocker Shaft For Zigzag	29	G-16	DPN-AD0041	Knuckle Pin	59	N-70
CST-LH0006	Table Stand Ass'y	67	Q-3	DBS-DA0073	Needle Bar Driving Lever Brush(L)	19	C-71	DPN-AD0042	Lever Moving Pin For Upper Thread Trim	23	E-6
CST-MF0001	Thread Stand Ass'y	69	R-28	DBS-DA0074	Needle Bar Driving Lever Brush(L)	19	C-72	DPN-AD0047	Guide For Spreader Compression Spring	47	L-23
CST-MF0003	Thread Stand Ass'y(For 3T)	67	Q-1	DBS-DB0009	Bushing For Bed Hinge Shaft	11	A-77	DPN-AD0048	Looper Cam Roller Pin	55	M-3
CTA-BB0002	Gimp Thread Guide Lever Bracket	57	N-51	DBS-DB0018	Needle Bar Bush(U)	17	C-53	DPN-BA0003	Moving Mes Return Spring Holder	49	L-61
CTA-BD0003	Spring Cover	57	N-5	DBS-DB0019	Zigzag Crank Shaft Bushing	29	G-18	DSC-AA0021	Plug	85	X-56
CTA-BJ0002	Thread Guide Disk Presser Plate	57	N-4	DBS-DB0020	Bushing For LTT Lever Arm	25	F1-30	DSC-AC0005	Screw(M3xL6)	33	I-26
CTA-BJ0005	Driving Plate For Gimp Thread Guide Lever	57	N-55	DBS-DB0020	Bushing For LTT Lever Arm	27	F2-15	DSC-AC0005	Screw(M3xL3.8)	43	K-36
CTA-BN0002	Spring Stopper	57	N-7	DBS-DB0021	Cam Lever Bushing(B)	55	M-15	DSC-AC0005	Screw(M3xL6)	47	L-37
CTA-CL0001	Roller For Gimp Thread Guide Lever Driving Plate	59	N-58	DCL-AA0003	Needle Bar Rocking Shaft Collar	31	H-25	DSC-AC0005	Screw(M3xL5)	51	L1-66
CTA-CM0001	Gimp Thread Guide Lever	59	N-60	DCL-AA0010	Upper Shaft Collar	15	B-5	DSC-AZ0001	Table Fixed Bolt	67	Q-7
CTA-CM0002	Gimp Thread Guide Driving Lever	59	N-61	DCL-AA0016	Lower Shaft Collar	21	D-2	DSC-BA0001	Screw(9/64" n=40)	79	V-10
CTA-HL0004	Thread Guide Disk	57	N-3	DCL-AA0019	Collar For Needle Bar Driving Gear Shaft	17	C-47	DSC-BA0005	Screw(3/16" n=28)	9	A-28
CTA-HL0005	Sub Thread Guide Disk	57	N-18	DCL-AA0023	Collar For Needle Bar Driving Lever	17	C-39	DSC-BA0009	Screw(9/64" n=40, L=5.5)	51	L1-77
CTA-HM0006	Lower Thread Tension Disk	47	L-57	DCL-AA0024	Collar For Head Support Lever	11	A-87	DSC-BA0009	Screw(9/64" n=40)	51	L1-80
CTA-HM0007	Sub Thread Tension Adjusting Shaft	57	N-17	DCL-AA0025	Collar For Thread Take Up Lever Shaft	19	C-66	DSC-BA0009	Screw(9/64" n=40)	51	L1-83
CTA-HM0009	Lower Thread Tension Shaft	47	L-56	DCL-AA0025	Support Shaft Collar	55	M-7	DSC-BA0009	Screw(9/64" n=40)	53	L2-66
CTH-CL0001	Cam Roller For Thread Take Up Lever	19	C-63	DCL-AA0025	Support Shaft Collar	55	M-18	DSC-BA0009	Screw(9/64" n=40, L=5.5)	53	L2-84
CTH-KC0001	Shaft For Thread Take Up Lever	19	C-64	DCL-AA0027	Cutter Shaft Collar	43	K-26	DSC-BA0009	Screw(9/64" n=40)	53	L2-87
CTR-BJ0011	Tension Release Cylinder Support Plate	57	N-39	DCL-AA0029	Collar For Lever Shaft	23	E-4	DSC-BA0009	Screw(9/64" n=40)	57	N-26
CTR-CA0005	Thread Release Driving Plate	57	N-10	DCL-AB0007	Rear Bearing Bushing For Lower Shaft	21	D-13	DSC-BA0009	Screw(9/64" n=40)	61	O-3
CTR-CA0006	Link For Thread Release Driving Plate	57	N-12	DCL-AC0001	Collar For Needle Bar Block	17	C-20	DSC-BA0009	Felt Fixed Screw(9/64" n=40)	61	O-5
CTR-CM0001	Upper Thread Adjusting Lever(Ass'y)	57	N-14	DCL-AC0001	Collar For Zigzag Crank Shaft	29	G-20	DSC-BA0009	Screw(9/64" n=40)	61	O-10
CUS-CP0001	Hand Pulley	15	B-2	DCL-AC0001	Clamp For Looper Driving Shaft	47	L-6	DSC-BA0009	Felt Fixed Screw(9/64" n=40)	61	O-21
CUS-DF0001	Upper Shaft Zigzag Cam	15	B-12	DGR-AA0020	X-Driving Gear	33	I-10	DSC-BA0009	Screw(9/64" n=40)	83	W-78
CUS-KC0004	Upper Shaft	15	B-1	DGR-AA0021	Y-Driving Gear	33	I-36	DSC-BA0009	Screw(9/64" n=40)	87	X-67
CUT-BJ0001	Cylinder Support Plate For UTT	23	E-16	DGR-AA0022	Y-Driven Gear	33	I-38	DSC-BA0012	Screw(3/32" n=56, L=8.4)	25	F1-9
CUT-BM0001	Cylinder Knuckle	23	E-13	DGR-AA0023	X-Driven Gear(Ass'y)	33	I-12	DSC-BA0012	Screw(3/36" n=56)	71	S-5
CUT-BM0001	Sub Clamp Cylinder Knuckle	41	J2-93	DGR-AB0007	Upper Shaft Needle Bar Gear	15	B-14	DSC-BA0018	Screw(9/64" n=40)	47	L-4
CUT-BM0001	Thread Release Cylinder Knuckle	59	N-69	DGR-AF0007	X-Feed Rack Gear	33	I-17	DSC-BB0004	Screw(11/64" n=40)	25	F1-43
CUT-CM0001	Upper Thread Trim Lever	23	E-3	DPK-AZ0004	Cylinder Shaft Rubber Packing	37	J-11	DSC-BB0005	Safety Plate Fixed Screw(11/64" n=40)	9	A-17
CUT-KC0001	Upper Thread Trim Lever Shaft	23	E-1	DPK-CA0007	Oil Cap	61	O-48	DSC-BB0016	Screw(M3xL4)	25	F1-5
CXF-BA0015	X-Y Feed Base	33	I-1	DPK-CA0008	Oil Cap	61	O-46	DSC-BB0017	Screw	25	F1-26
CXF-BB0013	X-Motor Base	33	I-5	DPK-CA0008	Oil Cap	61	O-47	DSC-BB0017	Screw(1/8" n=40)	27	F2-10
CXF-BB0014	Y-Feed Shaft Holder(L)	35	I-66	DPK-CA0008	Oil Cap	63	O-62	DSC-BB0018	Screw(11/64" n=40)	33	I-4
CXF-BB0015	Y-Feed Shaft Holder(R)	35	I-67	DPK-CA0011	Rubber Cap	11	A-108	DSC-BC0005	Screw A (3/32" n=56, L=3.2)	25	F1-28
CXF-BJ0024	X-Feed Sensor Bracket	33	I-29	DPK-CB0002	Rubber Cap	11	A-106	DSC-BF0001	Screw (1/8" n=44)	17	C-5
CXF-BJ0025	Sensor Space Plate	35	I-76	DPK-CB0007	Rubber Cap	11	A-107	DSC-BF0001	Screw (1/8" n=44, L=5)	21	D-5
CXF-KC0007	X-Feed Guide Shaft A	33	I-19	DPK-CB0007	Rubber Cap	11	A-110	DSC-BF0002	Screw(11/64" n=40)	15	B-4
CXF-KD0001	X-Driven Gear Shaft	33	I-14	DPK-CB0008	Rubber Cap	13	A-133	DSC-BF0010	Screw(11/64" n=40)	9	A-7
CXF-KD0002	X-Feed Guide Shaft B	33	I-22	DPK-CB0014	Rubber Cap For Zigzag Rocker Shaft	11	A-98	DSC-BF0010	Screw(11/64" n=40)	9	A-12
CXF-KD0003	Y-Feed Guide Shaft	35	I-68	DPK-CB0015	Rubber Cap	11	A-105	DSC-BF0010	Screw(11/64" n=40)	9	A-19

# Index

Parts No.	Name of Parts	Page	Ref.No.	Parts No.	Name of Parts	Page	Ref.No.	Parts No.	Name of Parts	Page	Ref.No.
DSC-BF0010	Screw(11/64" n=40)	9	A-25	DSC-CA0009	Screw(15/64" n=28)	11	A-79	DSC-FA0079	Stud For Gimp Thread Guide Lever Driving Plate	57	N-57
DSC-BF0010	Screw(11/64" n=40)	9	A-31	DSC-CA0018	Support Screw(M14xP1.5)	43	K-9	DSC-FA0080	Stud For Gimp Thread Guide Lever	57	N-56
DSC-BF0010	Screw (11/64" n=40)	17	C-26	DSC-CA0020	Upper Thread Trim Lever Stopper	23	E-11	DSC-FA0082	Stud Screw For Spreader Cam Link(A)	47	L-19
DSC-BF0010	Screw (11/64" n=40)	41	J2-90	DSC-CB0004	Screw(1/4" n=40)	15	B-9	DSC-FA0083	Stud Screw For Spreader Cam Link(B)	47	L-21
DSC-BF0010	Screw(11/64" n=40)	57	N-24	DSC-CB0004	Screw(1/4" n=40)	15	B-13	DSC-FA0084	Stud Screw For Looper Link	47	L-14
DSC-BF0010	Screw(11/64" n=40)	57	N-34	DSC-CB0004	Screw(1/4" n=40)	15	B-15	DSC-FA0090	Stud Screw For Hand Switch Level(11/64" n=40)	71	S-10
DSC-BF0010	Screw(11/64" n=40)	57	N-40	DSC-CB0004	Screw (1/4" n=40)	17	C-40	DSC-FA0092	Link Stud Screw(11/64" n=40)	37	J-3
DSC-BF0010	Screw(11/64" n=40)	57	N-52	DSC-CB0004	Screw (15/14" n=28)	17	C-48	DSC-FA0093	Stud Screw For Presser Plate Cover(11/64" n=40)	37	J-22
DSC-BF0010	Screw(11/64" n=40)	59	N-79	DSC-CB0004	Screw (1/4" n=40)	21	D-8	DSC-FA0094	Stud Screw For Tension Release Claw	51	L1-93
DSC-BF0010	Fixed Screw(11/64" n=40)	71	S-13	DSC-CB0004	Screw (1/4" n=40)	21	D-11	DSC-FD0004	Stud Screw For Thread Guide Plate	17	C-9
DSC-BF0013	Screw(3/32" n=56)	25	F1-36	DSC-CB0004	Screw (1/4" n=40)	33	I-23	DSC-FD0007	Stud Screw For Thread Tension Spring	47	L-55
DSC-BF0013	Screw (3/32" n=56)	39	J1-54	DSC-CB0004	Screw(15/64" n=40)	33	I-37	DSC-FF0006	Shaft For Thread Take-up Lever Cam Roller	19	C-61
DSC-BF0013	Screw (3/32" n=56)	41	J2-54	DSC-CB0004	Screw(15/64" n=28)	33	I-39	DSC-FF0007	Lever Support Screw	23	E-9
DSC-BF0026	Screw (3/16" n=32)	37	J-35	DSC-CB0004	Screw(1/4" n=40)	33	I-44	DSC-FF0007	Pin For Work Clamp Support (M3)	39	J1-71
DSC-BF0054	Screw(M4xL8)	55	M-21	DSC-CB0005	Screw(15/64" n=28)	11	A-82	DSC-FF0007	Pin For Work Clamp Support(M3)	41	J2-63
DSC-BF0073	Screw For Oil Support Cap	11	A-89	DSC-CB0005	Screw(15/64" n=28)	11	A-84	DSC-GA0005	Spreader Cam Lever Roller Pin	55	M-26
DSC-BF0076	Set Screw For Hammer Presser Plate	43	K-3	DSC-CB0005	Screw(15/64" n=28)	15	B-3	DSC-GB0002	Support Pin For Zigzag	29	G-2
DSC-BF0078	Screw (3/16" n=32)	37	J-38	DSC-CB0005	Screw(15/64" n=28)	15	B-6	DSC-GC0001	Stud B For Zigzag Crank	29	G-11
DSC-BF0082	Screw(M2.6xP0.45)	47	L-30	DSC-CB0005	Screw (15/64" n=28)	17	C-38	DSC-HB0003	Cover Support Bar	9	A-27
DSC-BF0082	Screw(M2.6xP0.45)	47	L-35	DSC-CB0005	Screw (15/64" n=28)	17	C-42	DSC-HB0010	Motor Cover Support Bar	9	A-24
DSC-BF0086	Cylinder Fix Screw	37	J-6	DSC-CB0005	Screw (15/64" n=28)	17	C-46	DSC-HD0004	Hook for Thread Take Up Lever Return Spring	17	C-58
DSC-BH0001	Screw(M4xL5)	27	F2-24	DSC-CB0005	Screw (15/64" n=20)	19	C-65	DSC-HD0005	Spring Hook	43	K-5
DSC-BH0002	Screw(M6xL6)	23	E-2	DSC-CB0005	Screw (15/64" n=28)	19	C-67	DSC-HD0007	Return Spring Holder For LTT(B)	25	F1-37
DSC-BJ0002	Screw(11/64" n=40)	9	A-14	DSC-CB0005	Screw (15/64" n=28)	21	D-14	DSC-HZ0002	Cutter Adjusting Screw	43	K-51
DSC-BJ0002	Screw(11/64" n=40)	9	A-22	DSC-CB0005	Screw(15/64" n=28)	31	H-7	DSC-HZ0003	Adjusting Screw For Moving Pin	23	E-7
DSC-BJ0002	Screw(11/64" n=40)	9	A-37	DSC-CB0005	Screw(15/64" n=28)	33	I-11	DSN-AA0007	Nut(15/64" n=28)	57	N-32
DSC-BJ0002	ScrewB(11/64" n=40)	9	A-38	DSC-CB0005	Screw (15/64" n=28)	33	I-13	DSN-AA0009	Nut(11/64" n=40)	9	A-42
DSC-BJ0002	Screw(4525)	11	A-103	DSC-CB0005	Screw(15/64" n=28)	35	I-69	DSN-AA0009	Nut(M4)	25	F1-40
DSC-BJ0002	Screw(11/64" n=40)	35	I-65	DSC-CB0005	Screw(15/64" n=28)	43	K-8	DSN-AA0009	Nut(M4)	27	F2-21
DSC-BJ0002	Screw(9/64" n=40)	35	I-75	DSC-CB0005	Screw(15/64" n=28)	43	K-13	DSN-AA0009	Nut(11/64" n=40)	41	J2-85
DSC-BJ0002	Screw (11/64" n=40)	37	J-14	DSC-CB0005	Screw(15/64" n=28)	43	K-16	DSN-AA0009	Nut(11/64" n=40)	71	S-3
DSC-BJ0002	Screw (11/64" n=40)	37	J-20	DSC-CB0005	Screw(15/64" n=28)	43	K-18	DSN-AA0009	Nut(11/64" n=40)	71	S-11
DSC-BJ0002	Screw(11/64" n=40)	43	K-42	DSC-CB0005	Screw(15/64" n=28)	43	K-23	DSN-AA0010	Nut(9/64" n=40)	57	N-22
DSC-BJ0002	Screw(11/64" n=40)	43	K-55	DSC-CB0005	Screw(15/64" n=28)	43	K-25	DSN-AA0017	Nut(1/8" n=40)	41	J2-82
DSC-BJ0002	Screw(11/64" n=40)	57	N-28	DSC-CB0005	Screw(15/64" n=28)	43	K-27	DSN-CD0001	Nut	57	N-8
DSC-BJ0002	Screw(11/64" n=40)	57	N-30	DSC-CB0005	Screw(15/64" n=28)	55	M-6	DSN-CD0004	Nut	49	L-59
DSC-BJ0002	Screw(11/64" n=40)	57	N-38	DSC-CB0005	Screw(15/64" n=28)	55	M-8	DSN-CD0004	Nut	57	N-20
DSC-BJ0002	Screw(11/64" n=40)	57	N-45	DSC-CB0005	Screw(15/64" n=28)	55	M-17	DSN-CD0004	Nut	59	N-74
DSC-BJ0002	Screw(11/64" n=40)	57	N-48	DSC-CB0005	Screw(15/64" n=28)	55	M-19	DSN-CY0003	Nut For Needle Bar Bush	17	C-50
DSC-BJ0002	Screw(11/64" n=40)	57	N-50	DSC-CB0007	Screw(M5xL6)	21	D-3	DSP-AA0026	Spring For Needle Bar Guide	17	C-13
DSC-BJ0002	Screw(9/64" n=40)	61	O-15	DSC-CB0007	Screw(15/64" n=28)	29	G-19	DSP-AB0012	Return Spring For Thread Take Up Lever	19	C-59
DSC-BJ0002	Screw(11/64" n=40)	61	O-17	DSC-CB0007	Screw(M5)	33	I-53	DSP-AB0013	Return Spring For Cutter Lever	43	K-48
DSC-BJ0002	Screw(11/64" n=40)	61	O-19	DSC-CB0007	Pin Fixed Screw (M5)	37	J-10	DSP-AB0015	Return Spring For Presser Plate	37	J-33
DSC-BJ0002	Screw(11/64" n=40)	61	O-23	DSC-CB0007	Screw (M5)	37	J-27	DSP-AB0016	Lower Thread Trim Return Spring	25	F1-34
DSC-BJ0002	Screw(11/64" n=40)	61	O-42	DSC-CB0007	Screw (M5)	39	J1-60	DSP-AB0021	Spring For Gimp Thread Guide Lever Driving Plate	57	N-54
DSC-BJ0002	Screw(11/64" n=40)	79	V-24	DSC-CB0007	Screw (M5)	39	J1-66	DSP-AB0023	Moving Mes Return Spring	49	L-60
DSC-BJ0003	Looper Base Bushing Screw(9/64" n=40)	9	A-5	DSC-CB0007	Screw (M5)	41	J2-59	DSP-AB0024	Return Spring For Cloth-Opening	37	J-12
DSC-BJ0003	Screw (9/64" n=40)	17	C-57	DSC-CB0007	Screw (M5)	41	J2-71	DSP-AC0005	Spring For Head Support Lever	11	A-86
DSC-BJ0003	Screw	61	O-56	DSC-CB0007	Screw(M5xL=6)	57	N-43	DSP-AC0025	Spring For Gimp Thread Guide Lever	57	N-53
DSC-BJ0003	Screw(9/64" n=40)	79	V-13	DSC-CB0010	Screw(1/4" n=40)	31	H-26	DSP-AC0026	Spring For Switch Lever	71	S-1
DSC-BJ0004	Screw (11/64" n=40)	39	J1-56	DSC-FA0001	Stud Screw For Spring Support	71	S-2	DSP-AC0027	Needle Guide Support Spring(L)	47	L-40
DSC-BJ0004	Screw(11/64" n=40)	41	J2-67	DSC-FA0043	Stud Screw(11/64" n=40)	9	A-40	DSP-AC0028	Needle Guide Support Spring(R)	47	L-41
DSC-BJ0011	Screw(9/64" n=40)	79	V-19	DSC-FA0043	Stud Screw Thread Release	57	N-11	DSP-AC0029	Spring For Tension Release Claw	51	L1-92
DSC-BJ0022	Screw B (3/32" n=56, L=2.2)	25	F1-29	DSC-FA0044	Stud Screw(15/64" n=28)	11	A-62	DSP-AC0030	Tension Release Lever Spring	51	L1-85
DSC-BJ0023	Stud ScrewB(9/64" n=40)	9	A-35	DSC-FA0061	Stud ScrewA(11/64" n=40)	9	A-33	DSP-AC0030	Tension Release Lever Spring	53	L2-89
DSC-BJ0025	Screw For Cloth Guide(9/64" n=40)	39	J1-46	DSC-FA0064	Stud A For Zigzag Crank	29	G-7	DSP-AD0011	Spring Plate For Needle Bar	17	C-52
DSC-BJ0025	Screw For Cloth Guide(9/64" n=40)	41	J2-46	DSC-FA0066	Stud Screw For Link Lever	25	F1-39	DSP-AD0012	Spring Plate	55	M-10
DSC-BJ0025	Screw(9/64" n=40)	51	L1-74	DSC-FA0066	Stud Screw For Link Lever	27	F2-20	DSP-BA0008	Spring For Thread Guide Plate	17	C-8
DSC-BJ0025	Screw(9/64" n=40)	53	L2-81	DSC-FA0069	Stud Screw For Opener	25	F1-24	DSP-BA0008	Thread Tension Spring	47	L-54
DSC-BJ0026	Screw(3/32" n=56, L=5.5)	25	F1-15	DSC-FA0077	Stud For Thread Release Driving Plate Link	57	N-13	DSP-BA0011	Lower Thread Tension Spring	49	L-58
DSC-BJ0026	Screw(3/32" n=56)	25	F1-31	DSC-FA0078	Fix Stud screw(11/64" n=40)	41	J2-84	DSP-BA0011	Sub Thread Tension Adjusting Spring	57	N-19
DSC-BJ0026	Screw(3/32" n=56)	27	F2-16	DSC-FA0078	Stud For Upper Thread Adjusting Lever	57	N-15	DSP-BA0011	Gimp Thread Tension Adjusting Spring	59	N-73

# Index

Parts No.	Name of Parts	Page	Ref.No.	Parts No.	Name of Parts	Page	Ref.No.	Parts No.	Name of Parts	Page	Ref.No.
DSP-BA0012	Thread Tension Adjusting Spring	57	N-6	GP-001689	Needle Plate L3(R)	41	J2-47	GP-002049	Limit Switch Setting Plate	81	W-31
DSP-BB0003	Thread Take-Up Spring	47	L-48	GP-001690	Needle Plate L3(L)	41	J2-51	GP-002051	Feed Moving Block	81	W-37
DWS-AA0006	Washer	11	A-76	GP-001691	Clamp Arm(R)	41	J2-60	GP-002052	Cylinder Setting Bracket	81	W-40
DWS-AA0006	Washer	31	H-5	GP-001692	Clamp Arm(L)	41	J2-72	GP-002053	Spring For Feed Pin	81	W-46
DWS-AA0006	Washer	33	I-48	GP-001693	Arm For Sub Clamp	41	J2-75	GP-002054	Guide Plate For Feed Pin	81	W-47
DWS-AA0006	Washer	37	J-7	GP-001694	Clamp L3(L)	41	J2-74	GP-002055	Cloth Feed Bar Guide(L)	81	W-49
DWS-AA0006	Washer	57	N-41	GP-001695	Clamp L3(R)	41	J2-62	GP-002056	Feed Base(L)	81	W-53
DWS-AA0006	Washer	79	V-25	GP-001696	Holder For Sub Clamp Arm	41	J2-78	GP-002057	Cloth Feed Bar Guide(R)	81	W-57
DWS-AA0011	Washer	19	C-73	GP-001697	Clamp Link Ass'y	41	J2-83	GP-002058	Lower Thread Trim Cover Plate(C)	83	W-60
DWS-AA0011	Washer	31	H-14	GP-001698	Cylinder Support Ass'y	41	J2-89	GP-002059	Cover For Presser Plate(B)	83	W-61
DWS-AA0011	Washer	31	H-17	GP-001699	Cover Plate(L)	41	J2-49	GP-002060	Manifold Bracket	83	W-62
DWS-AA0011	Washer	31	H-33	GP-001700	Cover Plate(R)	41	J2-44	GP-002115	Hand Switch	71	S-4
DWS-AA0011	Washer	33	I-21	GP-001701	Hammer-S20mm	43	K-29	GP-002147	Sub Clamp Air Cylinder	41	J2-91
DWS-AA0011	Washer	35	I-78	GP-001702	Hammer-S24mm	69	R-24	GP-002169	Threader	69	R-8
DWS-AA0011	Washer	37	J-15	GP-001752	Clamp Link Roller	41	J2-88	GP-002170	Bed Base(T) (Option)	11	A-113
DWS-AA0011	Washer	51	L1-78	GP-001753	Stud Screw For Roller(M4)	41	J2-86	GP-002171	Bed Base Support Rubber (Option)	11	A-114
DWS-AA0011	Washer	51	L1-81	GP-001754	Gimp Thread Tension Release Plate	59	N-77	GP-002172	Table(T) (Option)	67	Q-11
DWS-AA0011	Washer	51	L1-84	GP-001755	Gimp Thread Guide(J)	59	N-82	GP-002173	Thread Nipper Return Spring	85	X-16
DWS-AA0011	Washer	51	L1-87	GP-001756	Gimp Thread Tension Release Driving Lever	59	N-80	GP-002174	Thread Nipper Lever Return Spring	85	X-35
DWS-AA0011	Washer	53	L2-85	GP-001802	Moving Mes Driving Cam	27	F2-1	GP-002175	Cam Lever Return Spring	85	X-34
DWS-AA0011	Washer	53	L2-88	GP-001803	Moving Mes(L)	27	F2-2	GP-002176	Spring For Cam Lever Support Bracket B	85	X-43
DWS-AA0011	Washer	53	L2-91	GP-001804	Lower Thread Retainer(B)	27	F2-3	GP-002177	Spring For Cylinder Support	85	X-42
DWS-AA0011	Washer	55	M-22	GP-001805	Moving Mes(R)	27	F2-5	GP-002178	Stud Screw For Thread Nipper Lever	85	X-36
DWS-AA0011	Washer	61	O-57	GP-001806	Stud Screw For LTT Moving Mes	27	F2-6	GP-002179	Stud Screw For Cam Lever	85	X-33
DWS-AA0021	Washer	37	J-4	GP-001807	Moving Mes Support	27	F2-9	GP-002180	Support Guide Shaft	85	X-11
DWS-AA0035	Washer For Upper Shaft(A)	15	B-16	GP-001808	Moving Mes Driving Spring(L)	27	F2-11	GP-002181	Upper Thread Nipper Support Shaft	85	X-9
DWS-AA0036	Washer For Upper Shaft(B)	15	B-11	GP-001809	Moving Mes Driving Spring(R)	27	F2-12	GP-002182	Support A For Support Shaft	85	X-5
DWS-AA0059	Needle Bar Bush(U) Washer	19	C-70	GP-001810	Base For LTT Link Lever	27	F2-13	GP-002183	Support B For Support Shaft	85	X-8
DWS-AA0060	Washer A For Needle Bar Block	17	C-18	GP-001811	Lower Thread Trim Lever Arm	27	F2-17	GP-002184	Cylinder Setting Bracket	85	X-24
DWS-AA0061	Washer B For Needle Bar Block	17	C-15	GP-001814	Lower Thread Trim Cover Plate(B)	27	F2-23	GP-002185	Lever For Thread Nipper	85	X-19
DWS-AA0064	Washer For Zigzag Fork Support Pin	29	G-3	GP-001825	Return Spring For Gimp Thread Tension Release Lever	59	N-76	GP-002186	Manifold Bracket(D)	87	X-60
DWS-AA0065	Stud B Washer	29	G-13	GP-001883	Upper Thread Trimmer Mes(B)	53	L2-72	GP-002187	Bracket A For Cam Lever Support	85	X-28
DWS-AA0066	Spacer For Zigzag Crank	29	G-17	GP-001884	Stud Screw For Gimp Thread Clamp Plate	53	L2-78	GP-002188	Cam Lever Ass'y For U-Thread Nipper	85	X-32
DWS-AA0067	Needle Bar Rotation Pulley (U) Washer	31	H-24	GP-001886	Moving Mes Bracket	53	L2-67	GP-002189	Cam Lever Support Bracket B	85	X-29
DWS-CA0001	Spring Washer	15	B-23	GP-001887	Moving Mes Bracket Holder	53	L2-65	GP-002190	Cover(D) For Needle Bar Timing Belt	85	X-40
DWS-CA0001	Washer(φ5)	35	I-79	GP-001888	Gimp Guide	53	L2-74	GP-002191	Support For Thread Nipper Setting Cylinder	85	X-27
DWS-CA0001	Spring Washer	43	K-43	GP-001889	Moving Mes Bracket Spring	53	L2-69	GP-002192	Support For Upper Thread Nipper Cylinder	85	X-2
DWS-CC0001	Wave Washer	9	A-34	GP-001890	Gimp Thread Clamp Plate Spring	53	L2-77	GP-002193	Cover For Needle Bar Timing Belt(C)	85	X-39
DWS-CC0001	Washer	9	A-41	GP-001891	Gimp Thread Clamp Plate	53	L2-76	GP-002194	Bracket For Upper Thread Nipper	85	X-1
DWS-CC0001	Washer	71	S-25	GP-001892	Bracket For Upper Thread Trimmer	53	L2-62	GP-002195	Thread Nipper A	85	X-12
EA-000114	Control Box Fan	73	T-16	GP-001893	Throat Plate(B)	53	L2-79	GP-002196	Thread Nipper B	85	X-13
EA-000250	OP Box(Ass'y)	77	U-14	GP-001957	Mounting Plate For Cylinder	79	V-5	GP-002197	Support For Upper Thread Nipper	85	X-18
EP-000039	SMPS	73	T-25	GP-001958	Sensor Bracket	79	V-17	GP-002198	Thread Nipper Air Cylinder	85	X-44
EP-000207	Cable Holder(50mm)	75	T-89	GP-001959	Sensor Detecting Plate	79	V-18	GP-002199	Thread Nipper Setting Air Cylinder	85	X-47
GP-000649	Table Support Plate	9	A-51	GP-001960	Setting Plate For Cylinder	79	V-7	GP-002200	Support DU-Bushing	85	X-6
GP-001083	Shaft For Idler	21	D-17	GP-001961	Setting Plate For Sensor	79	V-23	GP-002201	Pneumatic I/O Cable	87	X-63
GP-001086	Bracket For Idler	21	D-16	GP-001962	Hammer Plate(7mm)	79	V-14	GP-002279	Hammer-36mm	69	R-30
GP-001093	Holder For Setting Shaft	79	V-26	GP-001963	Hammer Setting Lever	79	V-12	GP-002376	Cylinder Auto Switch	25	F1-47
GP-001149	Upper Thread Trimmer Moving Mes	51	L1-67	GP-001964	Support Plate For Cylinder	79	V-9	GP-002376	Cylinder Auto Switch	81	W-20
GP-001163	Spreader Compression Spring	47	L-22	GP-001965	Cover For Needle Bar Timing Belt(B)	79	V-20	GP-002379	Cover For Gimp Thread Take-up Lever Ass'y-B	11	A-118
GP-001222	Spreader(R)	47	L-32	GP-002037	Cloth Feed Bar	81	W-1	GP-004727	Sensor Ass'y	79	V-16
GP-001223	Spreader(L)	47	L-31	GP-002038	Cloth Feed Plate(L)	81	W-2	GP-004728	Photo Sensor Ass'y	79	V-21
GP-001224	Looper(R)	47	L-29	GP-002039	Cloth Setting Guide(L)	81	W-4	GP-004859	Rotary Air Cylinder	79	V-1
GP-001225	Looper(L)	47	L-28	GP-002040	Cloth Setting Spring Plate	81	W-7	GP-005223	Support For Upper Thread Presser	83	W-76
GP-001680	Looper Base Bushing	9	A-4	GP-002041	Cloth Feed Plate(R)	81	W-9	GP-005223	Support For Upper Thread Presser	87	X-65
GP-001684	Sub Clamp Arm Retn Spring	41	J2-77	GP-002042	Cloth Setting Guide(R)	81	W-11	GP-005224	Plate For Upper Thread Presser	83	W-77
GP-001685	Shaft For Clamp Lever(L)	41	J2-68	GP-002043	Cloth Setting Guide	81	W-14	GP-005224	Plate For Upper Thread Presser	87	X-66
GP-001686	Sub Clamp Arm Holder Shaft	41	J2-79	GP-002044	Feed Base(L)	81	W-17	GP-005979	Pneumatic I/O Cable	79	V-36
GP-001687	Rubber Cap For Sub Clamp Arm	41	J2-76	GP-002045	Cloth Feed Cylinder Rod	81	W-22	GP-005980	Solenoid Valve	79	V-30
GP-001687	Air Cylinder Rubber Cap	81	W-56	GP-002046	Cloth Feed Cylinder Rod Stud Screw	81	W-23	GP-005994	Cloth Feed Air Cylinder	81	W-19
GP-001687	Air Cylinder Rub Cap	85	X-50	GP-002047	Feed Guide Shaft	81	W-24	GP-005995	Feed Pin Moving Air Cylinder	81	W-42
GP-001688	Shaft Holder For Clamp Lever(L)	41	J2-66	GP-002048	Stopper Block	81	W-26	GP-005995	Feed Base(L) Air Cylinder	81	W-54



# Index

Parts No.	Name of Parts	Page	Ref.No.	Parts No.	Name of Parts	Page	Ref.No.	Parts No.	Name of Parts	Page	Ref.No.
GP-006004	Limit Switch	81	W-34	PBR-AA0037	Bearing	33	I-41	PPP-AF0002	Flug	83	W-69
GP-006012	Manifold Block	83	W-66	PBR-BA0014	Bearing for Needle Bar Driven Pulley	17	C-30	PPP-AG0001	Finger Valve	65	P-10
GP-006037	Nipple	79	V-34	PBR-BB0002	Trust Bearing	17	C-28	PPP-BA0004	Solenoid Valve	85	X-52
GP-006042	Shaft For Sensor Setting	79	V-28	PBR-BF0001	Needle Roller( $\phi 4 \times L25$ )	43	K-4	PPP-BA0005	Solenoid Valve	65	P-13
GP-007198	SMD FET Radiator Sheet	73	T-34	PBR-BF0002	Needle Roller( $\phi 3 \times L11.8$ )	43	K-6	PPP-BA0006	Solenoid Valve	65	P-19
GP-007203	Main Board Radiator	75	T-54	PBR-FA0007	X-Feed Liner Bush	33	I-24	PPP-BA0006	Air Solenoid Valve	83	W-65
GP-007346	Hand Switch Support Plate	81	W-36	PBR-FA0008	Y-Feed Liner Bush	33	I-55	PPP-BB0001	Manifold Block	85	X-53
GP-007711	Digital Board Sticker	75	T-66	PBR-GB0002	Rod End Bearing	29	G-5-2	PPP-BB0003	Manifold Block	65	P-20
GP-007713	Main Board Sticker	75	T-68	PBT-BC0003	Upper Shaft Timing Belt	15	B-10	PPP-BC0001	Silence	65	P-21
GP-008660	Cable Cover	75	T-64	PBT-BC0004	Needle Bar Rocking Timing Belt	31	H-28	PPP-BC0001	Silence	83	W-67
GP-008663	Lower Frame	73	T-13	PBT-BC0005	Looper Base Rocking Timing Belt	31	H-29	PPP-BC0001	Silence	87	X-58
GP-008666	Upper Frame	73	T-11	PBT-BF0001	Y-Feed Timing Belt	33	I-45	PPP-BC0002	Silence	79	V-31
GP-008667	Insulation Plate	73	T-20	PCR-AD0001	Upper Shaft Coupling	15	B-19	PPP-BD0002	Regulator	65	P-5
GP-008668	Digital Board Bracket	73	T-31	PMT-BH0005	Y-Feed Motor	33	I-33	PPP-BG0002	Air Presser Switch	65	P-11
GP-008670	Main Board Bracket	75	T-58	PMT-BH0006	X-Feed Motor	33	I-7	PPP-BH0001	Air Unit	65	P-4
GP-008671	Front Profile Upper	73	T-3	PN-000065	Opener Pin	25	F1-19	PPP-BJ0001	Bracket	65	P-6
GP-008672	Front Profile Lower	73	T-5	PN-000071	Moving Mes Bracket Pin	53	L2-68	PPP-CA0007	Safety Plate Air Cylinder	9	A-9
GP-008673	Rear Profile Upper	73	T-7	PN-000073	Feed Pin	81	W-44	PPP-CA0008	Cutter Air Cylinder	43	K-19
GP-008674	Rear Profile Lower	73	T-9	PN-000081	Thread Nipper Support Pin	85	X-14	PPP-CA0009	UTT Air Cylinder	23	E-18
GP-008701	SMPS Bracket	73	T-26	PN-000081	Lever Pin	85	X-20	PPP-CA0010	Presser Plate Air Cylinder	37	J-24
GP-010137	Caution Label	13	A-132	PPK-BA0001	Spacer O-Ring	15	B-18	PPP-CA0011	LTT Link Air Cylinder	25	F1-44
GP-010539	Gimp Thread Guide Disk	59	N-72	PPP-AA0001	Safety Plate Air Cylinder Fitting	9	A-10	PPP-CA0012	Thread Release Air Cylinder	57	N-35
GP-011455	Stand For OP Box	77	U-11	PPP-AA0001	Air Cylinder Fitting	23	E-19	PSC-AC0002	Screw(M4xL8)	33	I-30
GP-012617	Board Bracket Handle	73	T-32	PPP-AA0001	Air Cylinder Fitting A	25	F1-45	PSC-AC0002	Screw(M3xL5)	79	V-37
GP-012617	Board Bracket Handle	73	T-49	PPP-AA0001	Air Cylinder Fitting	41	J2-92	PSC-AC0002	Screw(M4xL10)	81	W-25
GP-012617	Board Bracket Handle	75	T-59	PPP-AA0001	Cutter Bracket Air Fitting	43	K-32	PSC-AC0002	Screw	81	W-27
GP-013452	Step Board Radiator Bracket	73	T-39	PPP-AA0001	Air Cylinder Fitting	57	N-36	PSC-AC0002	Screw(M4xL10)	81	W-32
GP-013453	Step Board Radiator	73	T-38	PPP-AA0001	Air Cylinder Fitting A	79	V-2	PSC-AC0002	Screw(M4xL10)	81	W-41
GP-013456	Step Board Bracket	73	T-48	PPP-AA0001	Hose Nipple A	79	V-32	PSC-AC0002	Screw(M4xL10)	81	W-48
GP-013457	Step Board Sticker	75	T-67	PPP-AA0001	Air Cylinder Fitting	81	W-21	PSC-AC0002	Screw(M4xL10)	85	X-3
GP-013459	Box Body	73	T-2	PPP-AA0001	Air Cylinder Fitting	81	W-43	PSC-AC0002	Screw(M4xL10)	85	X-7
GP-013461	Rear Cover	73	T-23	PPP-AA0001	Air Cylinder Fitting	81	W-55	PSC-AC0002	Screw(M4xL10)	85	X-25
GP-013468	Front Cover	77	U-2	PPP-AA0001	Air Cylinder Fitting	85	X-45	PSC-AC0002	Screw(M4xL10)	85	X-30
GP-013469	Rear Cover	77	U-7	PPP-AA0001	Air Cylinder Fitting	85	X-48	PSC-AC0002	Screw(M4xL10)	85	X-41
GP-013470	Membrane Switch	77	U-1	PPP-AA0002	Air Cylinder Fitting B	25	F1-46	PSC-AC0006	Screw (M6xL20)	29	G-10
GP-013601	Switch Cover	77	U-6	PPP-AA0002	Cylinder Hose Nipple	37	J-8	PSC-AC0006	Screw(M6xL20)	31	H-2
GP-013610	Step Board Radiator Sub Bracket	73	T-40	PPP-AA0002	Air Cylinder Fitting B	79	V-3	PSC-AC0006	Screw(M6xL20)	33	I-6
GP-013846	Radiator Sheet B	73	T-41	PPP-AA0002	Hose Nipple B	79	V-33	PSC-AC0006	Screw(M6xL20)	33	I-32
GP-013874	Voltage Sticker	75	T-70	PPP-AA0002	Hose Nipple	85	X-55	PSC-AC0008	Screw (M4xL8)	17	C-24
GP-014587	Upper Cover	73	T-15	PPP-AA0015	Cutter Air Cylinder Fitting	43	K-20	PSC-AC0008	Screw(M4xL10)	31	H-13
GP-014959	Model Mark(01)	11	A-94	PPP-AA0015	Nipple	65	P-7	PSC-AC0008	Screw(M4xL10)	31	H-16
GP-014960	Model Mark(02)	11	A-95	PP-AA00160	Elbow Union A	65	P-17	PSC-AC0009	Screw (M5xL15)	39	J1-62
GP-017451	Pause Switch(Ass'y)	9	A-29	PPP-AA0017	Elbow Union B	65	P-16	PSC-AC0009	Screw (M5xL15)	39	J1-68
GP-018205	CE Mark	11	A-123	PPP-AA0019	Nipple	65	P-22	PSC-AC0009	Screw(M5xL15)	41	J2-61
GP-019627	Upper Thread Sticker	11	A-124	PPP-AA0020	Straight	65	P-35	PSC-AC0009	Screw(M5xL15)	41	J2-73
GP-019628	Lower Thread Sticker	11	A-125	PPP-AA0021	Elbow Union	65	P-8	PSC-AC0009	Stopper Screw(M5xL15)	81	W-51
GP-022099	Spacer Spring	49	L-62	PPP-AA0022	Coupling	65	P-9	PSC-AC0012	Screw(M6xL15)	11	A-88
GP-023880	Hose A	43	K-59	PPP-AA0028	Half Union	83	W-68	PSC-AC0012	Screw(M6xL15)	35	I-77
GP-023883	Pocket	45	K-60	PPP-AA0028	Half Union	85	X-57	PSC-AC0013	Screw(M5xP0.8)	15	B-22
GP-027061	Fan Bracket	75	T-90	PPP-AB0001	Air Cylinder Fitting	37	J-25	PSC-AC0013	Screw(M5xL20)	21	D-18
GP-047599	QC Passed Sticker	75	T-69	PPP-AB0002	Speed Controller	65	P-23	PSC-AC0015	Screw(M4xL8)	31	H-32
MO-00000	Needle Bar Rocking Motor	31	H-3	PPP-AB0003	Presser Gauge	65	P-14	PSC-AC0017	Screw(M5xL10)	11	A-75
PBR-AA0001	Upper Shaft Bearing(R)	15	B-17	PPP-AB0011	Speed Controller	85	X-54	PSC-AC0017	Screw(M5xL10)	43	K-34
PBR-AA0013	Lower Shaft Bearing(F)	21	D-6	PPP-AB0018	Nipple	85	P-15	PSC-AC0017	Cutter Bracket Screw (M5xL10)	43	K-39
PBR-AA0021	Upper Shaft Bearing(F)	15	B-7	PPP-AD0001	Air Tube( $\phi 4$ )	65	P-26	PSC-AC0020	Screw(M3xL10)	11	A-93
PBR-AA0022	Lower Shaft Bearing(R)	21	D-12	PPP-AD0001	Air Tube( $\phi 4$ )	79	V-4	PSC-AC0037	Screw(M5xL20)	79	V-27
PBR-AA0022	Bearing	47	L-2	PPP-AD0001	Air Tube( $\phi 4$ )	83	W-72	PSC-AC0039	Filter Regulator ASM. Screw(M5xL10)	65	P-28
PBR-AA0030	Idler Bearing	21	D-21	PPP-AD0001	Air Tube( $\phi 4$ )	85	X-46	PSC-AC0041	Screw(M4xL8)	25	F1-2
PBR-AA0030	Bearing	33	I-15	PPP-AD0001	Air Tube( $\phi 4$ )	85	X-49	PSC-AC0041	Screw(M4xL8)	25	F1-33
PBR-AA0033	Needle Bar Rocking Shaft Bearing(U)	31	H-27	PPP-AD0002	Air Tube( $\phi 6$ )	83	W-71	PSC-AC0041	Screw(M4xL8)	27	F2-18
PBR-AA0034	Needle Bar Rocking Shaft Bearing(D)	31	H-21	PPP-AD0002	Air Tube( $\phi 6$ )	87	X-59	PSC-AC0041	Screw(M4xL8)	59	N-64
PBR-AA0035	Idler Pulley Bearing	31	H-9	PPP-AD0003	Air Tube( $\phi 10$ )	65	P-27	PSC-AC0041	Screw(M4xL8)	71	S-7

# Index

Parts No.	Name of Parts	Page	Ref.No.	Parts No.	Name of Parts	Page	Ref.No.	Parts No.	Name of Parts	Page	Ref.No.
PSC-AC0041	Screw(M4×L8)	81	W-50	PSC-BA0007	Screw(M4×L8)	53	L2-75	PSR-AA0005	C-Ring(φ10)	31	H-11
PSC-AC0050	Stopper Screw A(M4×L20)	37	J-16	PSC-BA0007	Screw(M4×L8)	59	N-62	PSR-AA0006	C-Ring(φ19)	33	I-56
PSC-AC0050	Stopper Screw B(M4×L20)	37	J-17	PSC-BA0007	Screw(M4×L8)	59	N-66	PSR-AB0006	C-Ring(φ28)	21	D-22
PSC-AC0061	Screw(M5×L15)	31	H-4	PSC-BA0007	Screw(M4×L8)	59	N-68	PSR-AB0006	C-Ring(φ28)	33	I-16
PSC-AC0061	Screw(M5×L15)	33	I-18	PSC-BA0007	Screw(M4×L8)	59	N-81	PSR-AB0007	C-Ring(φ26)	31	H-10
PSC-AC0061	Screw(M5×L15)	33	I-47	PSC-BA0007	Screw(M4×L8)	59	N-83	PSR-AB0008	C-Ring(φ16)	33	I-42
PSC-AC0061	Tension Adjusting Screw(M5×L20)	33	I-51	PSC-BA0008	Screw(M5×L12)	47	L-12	PSR-AC0002	E-Ring	23	E-20
PSC-AC0061	Screw(M5×L20)	35	I-61	PSC-BA0008	Screw(M5×L12)	47	L-17	PSR-AC0003	E-Ring(φ4)	23	E-15
PSC-AC0067	Screw(M4×L15)	9	A-58	PSC-BA0009	Screw(M4×L14)	47	L-47	PSR-AC0003	E-Ring(φ4)	37	J-30
PSC-AC0067	Screw(M4×L15)	31	H-23	PSC-BB0007	Guide Plate Screw(M3×L6)	37	J-41	PSR-AC0003	E-Ring(φ4)	41	J2-95
PSC-AC0067	Screw(M4×L10)	33	I-8	PSC-BB0007	Screw For Needle Plate(M3×L6)	39	J1-48	PSR-AC0003	E-Ring(φ4)	59	N-71
PSC-AC0067	Screw(M4×L15)	33	I-20	PSC-BB0007	Screw(M3×L6)	41	J2-48	PSR-AC0004	E-Ring(φ3)	51	L1-88
PSC-AC0068	Screw(M8×L25)	9	A-45	PSC-BB0007	Screw(M3×L6)	81	W-3	PSR-AC0004	E-Ring(φ3)	53	L2-92
PSC-AC0068	Bed Fixing Bolt	11	A-119	PSC-BB0007	Screw(M3×L6)	81	W-10	PSR-AC0005	E-Ring(φ6)	33	I-50
PSC-AC0069	Screw (M4×L30)	17	C-55	PSC-BF0002	Screw(11/64" n=40)	83	W-79	PSR-AD0013	E-Ring(φ2)	85	X-15
PSC-AC0070	Screw (M3 × L12)	17	C-33	PSC-CB0001	Screw(M6×L=8)	15	B-20	PSR-AD0013	E-Ring(φ2)	85	X-21
PSC-AC0070	Screw (M3×L12)	29	G-24	PSC-CB0001	Screw(M6×L6)	47	L-25	PSR-AG0001	G-Ring (φ5)	39	J1-58
PSC-AC0070	Stopper Screw(M3×L12)	51	L1-63	PSC-CB0001	Screw(M6×L6)	55	M-4	PSR-AG0001	G-Ring (φ5)	41	J2-57
PSC-AC0070	Stopper Screw(M3×L8)	53	L2-63	PSC-CB0002	Screw (M4×L4)	17	C-12	PSR-AG0001	G-Ring (φ5)	41	J2-69
PSC-AC0071	Screw(M4×L10)	11	A-127	PSC-CB0002	Screw(M4×L4)	23	E-5	PSR-AG0002	G-Ring(φ8)	11	A-73
PSC-AC0071	Screw(M4×L10)	23	E-17	PSC-CB0002	Screw(M4×L4)	41	J2-98	PTC-AG0001	Tie	61	O-59
PSC-AC0071	Screw(M4×L10)	35	I-72	PSC-CB0002	Screw(M4×L4)	81	W-30	PTC-AG0001	Cable Tie(M)	69	R-21
PSC-AC0071	Screw(M4×L10)	41	J2-96	PSC-CB0002	Screw(M4)	85	X-10	PTC-AG0002	Tie	61	O-55
PSC-AC0071	Cutter Bracket Screw A(M4×L10)	43	K-37	PSC-CB0010	Adjusting Screw For Spreader Driving Lever	55	M-23	PTC-AG0002	Cable Tie(S)	69	R-20
PSC-AC0071	Screw(M4×L10)	43	K-50	PSC-CB0012	Stopper Screw(M3×L10)	51	L1-73	PTC-AG0002	Cable Tie(S)	79	V-39
PSC-AC0071	Screw(M4×L10)	43	K-53	PSC-CB0012	Stopper Screw(M3×L10)	53	L2-80	PTC-AG0002	Cable Tie(S)	83	W-75
PSC-AC0071	Screw(M4×L10)	43	K-58	PSC-DA0001	Screw Nail	65	P-2	PTC-AG0002	Cable Tie(S)	87	X-64
PSC-AC0072	Cutter Bracket Screw B(M6×L25)	43	K-38	PSC-DA0001	Bracket Fixing Screw Nail	83	W-63	PTC-AH0001	Code Holder(5N)	57	N-37
PSC-AC0073	Screw (M3×L12)	17	C-21	PSC-DA0001	Bracket Fixing Screw Nail	87	X-61	PTC-AH0001	Cable Holder(5N)	61	O-58
PSC-AC0073	Screw(M3×L15)	29	G-21	PSC-DD0002	Screw	69	R-27	PTC-AH0001	Code Holder(5N)	79	V-40
PSC-AC0073	Screw(M3×L12)	47	L-7	PSN-AA0002	Nut (M5)	19	C-62	PTC-AH0001	Code Holder(5N)	83	W-74
PSC-AC0074	Screw(M6×L14)	35	I-58	PSN-AA0002	Stopper Nut(M5×P0.8)	23	E-12	PTC-AH0002	Code Holder(5N)	35	I-74
PSC-AC0075	Screw(M3×L6)	59	N-87	PSN-AA0002	Connecting Bar Nut(M5)	29	G-6	PTC-AH0004	Code Holder(10N)	11	A-102
PSC-AC0076	Screw(M3×L6)	55	M-11	PSN-AA0002	Nut(M6×P1)	29	G-8	PTC-AH0005	Code Holder(3N)	43	K-57
PSC-AC0094	Setting Screw(M4×L15)	85	X-37	PSN-AA0002	Nut(M5)	55	M-28	PTC-AH0005	Code Holder(3N)	61	O-9
PSC-AC0101	Screw(M3×L12)	81	W-35	PSN-AA0002	Nut(M5)	65	P-30	PTL-AB0001	L-Shaped Wrench(2mm)	69	R-9
PSC-AC0103	Stopper Screw(M3×L8)	85	X-22	PSN-AA0004	Nut(M8×P1.25)	29	G-4	PTL-AB0002	L-Shaped Wrench(5mm)	69	R-13
PSC-AC0136	Screw(M3×L5)	79	V-15	PSN-AA0005	Nut(M8)	9	A-50	PTL-AB0003	L-Shaped Wrench(2.5mm)	69	R-10
PSC-AZ0001	Fixed Bolt(M8)	9	A-46	PSN-AA0005	Nut(M8)	9	A-56	PTL-AB0004	L-Shaped Wrench(4mm)	69	R-12
PSC-AZ0001	Fixed Bolt(M8)	9	A-53	PSN-AA0005	Nut(M8)	67	Q-10	PTL-AB0005	L-Shaped Wrench(3mm)	69	R-11
PSC-BA0002	Solenoid Valve A Screw(M4×L35)	65	P-31	PSN-AA0006	Nut (M6×P1.0)	19	C-68	PTL-BA0001	Driver(L)	69	R-1
PSC-BA0002	Solenoid Valve B Screw(M4×L35)	65	P-32	PSN-AA0006	Nut(M6×P1)	29	G-12	PTL-BA0002	Driver(M)	69	R-2
PSC-BA0002	Manifold Block Fixing Screw(M4×L35)	83	W-70	PSN-AA0007	Nut(M5)	81	W-52	PTL-BA0002	Driver(S)	69	R-3
PSC-BA0004	Screw(M3×L6)	25	F1-7	PSN-AA0015	Nut(M4)	11	A-60	PTL-CB0001	Spanner	69	R-4
PSC-BA0004	Screw(M3×L5)	25	F1-41	PSN-AA0015	Nut	41	J2-87	PWS-AA0002	Washer	11	A-59
PSC-BA0004	Screw(M3×L5)	27	F2-22	PSN-AA0015	Nut(M4)	55	M-24	PWS-AA0002	Washer	25	F1-48
PSC-BA0004	Screw(M3×L6)	47	L-10	PSN-AA0015	Nut(M4)	59	N-59	PWS-AA0002	Washer	33	I-9
PSC-BA0004	Screw(M3×L5)	47	L-51	PSN-AA0016	Nut(M14×P1.5)	43	K-10	PWS-AA0002	Washer	33	I-35
PSC-BA0004	Oil Felt Fix Screw(M3×L6)	61	O-31	PSN-AA0018	Nut(M3.5×P0.6)	23	E-8	PWS-AA0002	Washer	35	I-73
PSC-BA0004	Screw(M3×L5)	61	O-36	PSN-AA0019	Nut(M3×P0.5)	23	E-10	PWS-AA0002	Washer	61	O-32
PSC-BA0004	Screw(M3×L5)	79	V-8	PSN-AA0019	Nut (M3)	39	J1-73	PWS-AA0004	Washer	15	B-24
PSC-BA0004	Screw(M3×L5)	79	V-22	PSN-AA0019	Nut (M3)	41	J2-65	PWS-AA0004	Washer	21	D-19
PSC-BA0004	Screw(M3×L5)	81	W-8	PSN-AA0019	Stopper Nut(M3)	51	L1-64	PWS-AA0004	Washer	41	J2-99
PSC-BA0005	Screw (M3×L6)	17	C-17	PSN-AA0019	Stopper Nut(M3)	53	L2-64	PWS-AA0004	Washer	59	N-78
PSC-BA0005	Screw(M3×L6)	47	L-39	PSN-AA0020	Nut(M2)	25	F1-18	PWS-AA0004	Washer	59	N-88
PSC-BA0005	Screw(M3×L5)	61	O-25	PSN-AA0023	Nut(M4)	27	F2-7	PWS-AA0004	Washer	65	P-29
PSC-BA0005	Screw(M3×L3.5)	61	O-27	PSN-AA0023	Nut (M4)	37	J-18	PWS-AA0004	Washer	71	S-14
PSC-BA0005	Screw(M3×L6)	85	X-17	PSN-AA0023	Nut(M4)	51	L1-71	PWS-AA0009	Washer	81	W-6
PSC-BA0006	Screw(M2×L4)	25	F1-17	PSN-AA0023	Nut(M4)	85	X-38	PWS-AA0009	Washer	81	W-13
PSC-BA0007	Screw(M4×L8)	43	K-47	PSN-AA0024	Stopper Nut(M3)	85	X-23	PWS-AA0009	Washer	81	W-16
PSC-BA0007	Screw(M4×L8)	51	L1-70	PSR-AA0003	C-Ring(φ12)	21	D-23	PWS-AA0009	Washer	83	W-59
PSC-BA0007	Screw(M4×L8)	51	L1-90	PSR-AA0003	C-Ring(φ12)	81	W-39	PWS-AA0009	Washer	83	W-80

